

**PRODUCT NO: 3700F/NF/FG/NFG  
3800F/NF/FG/NFG  
3800F8/NF8/FG8/NFG8**

**NAME: INSULATED FOIL TOP REG. BOX  
WITH OR WITHOUT FLANGE /  
WITH OR WITHOUT GASKET**

**PRODUCT DATA SHEET**

**DATE:**  
03/18/13

**MODEL VARIATIONS**

3700F - R4 W/FLANGE	3700FG - R4 W/FLG+GASKET
3800F - R6 W/FLANGE	3800FG - R6 W/FLG+GASKET
3800F8 - R8 W/FLANGE	3800FG8 - R8 W/FLG+GASKET
3700NF - R4 NO FLANGE	3700NFG - R4 W/GSKT NO FLG
3800NF - R6 NO FLANGE	3800NFG - R6 W/GSKT NO FLG
3800NF8 - R8 NO FLANGE	3800NFG8 - R8 W/GSKT NO FLG

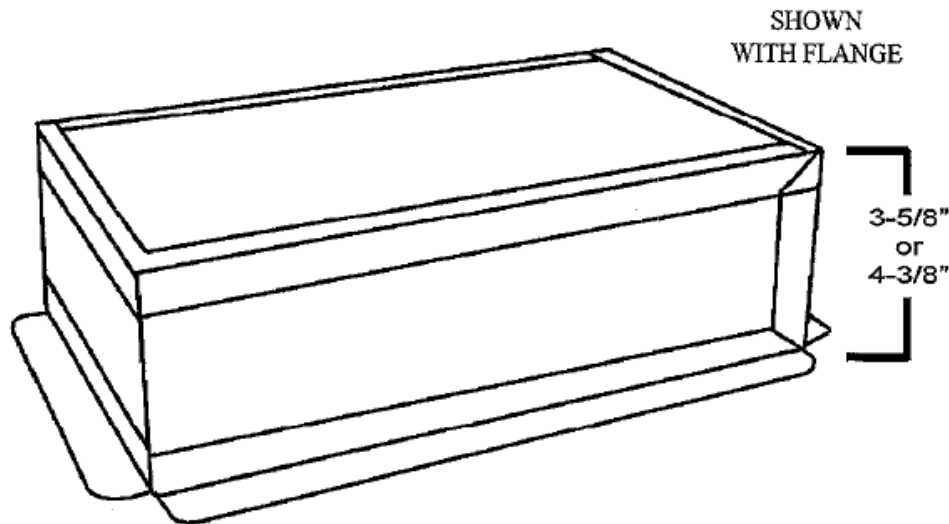

**PRODUCTION DATA**

WRAPPER FABRICATED FROM 30 GAUGE GALVANIZED STEEL.

DUCTBOARD TOP.

**PRODUCT CHARACTERISTICS**

R-4.2, R6.0, R8.0 INSULATION.

DUCTBOARD TOP ALLOWS FOR VARIOUS COLLAR INLET SIZES.

1/2" DRYWALL FLANGE.

BLACK INTERIOR.

12 HOLE CLUSTER FOR REG. ATTACHMENT.

**PRODUCT SIZE INFORMATION**

DEEP BOX = 4 3/8"

SHALLOW BOX = 3 5/8"

DEEP BOX DIMENSION IS 2 5/8" GREATER THAN REGISTER DIMENSION.

SHALLOW BOX DIMENSION IS 2" GREATER THAN REGISTER DIMENSION.

**NOTES:**

INTERNAL INSULATION MEETS THE REQUIREMENTS OF ASTM C 1338 (FORMERLY ASTM C 665) STANDARD TEST FOR FUNGI RESISTANCE.

**Snap-Rite**  
*Manufacturing, Inc.*

PO Box 577  
Coats, NC 27521  
PH: 910-897-4080  
FX: 910-897-0355

Cleveland, OH ❖ Lake Park, GA