

INSTALLATION INSTRUCTIONS

AIR-COOLED CONDENSING UNITS

(-)ASL-JEC 18 SEER EQUIPPED WITH THE *COMFORT CONTROL² SYSTEM™* AND FEATURING DUAL DRIVE COMPRESSORS IN SELECT MODELS



Comfort Control² System™

Featuring Industry Standard
R-410A Refrigerant ~~R-410A~~



RECOGNIZE THIS SYMBOL AS AN INDICATION OF IMPORTANT SAFETY INFORMATION!

▲ WARNING

THESE INSTRUCTIONS ARE INTENDED AS AN AID TO QUALIFIED, LICENSED SERVICE PERSONNEL FOR PROPER INSTALLATION, ADJUSTMENT AND OPERATION OF THIS UNIT. READ THESE INSTRUCTIONS THOROUGHLY BEFORE ATTEMPTING INSTALLATION OR OPERATION. FAILURE TO FOLLOW THESE INSTRUCTIONS MAY RESULT IN IMPROPER INSTALLATION, ADJUSTMENT, SERVICE OR MAINTENANCE POSSIBLY RESULTING IN FIRE, ELECTRICAL SHOCK, PROPERTY DAMAGE, PERSONAL INJURY OR DEATH.



ISO 9001:2008

Certificate Number: 30164

DO NOT DESTROY THIS MANUAL

PLEASE READ CAREFULLY AND KEEP IN A SAFE PLACE FOR FUTURE REFERENCE BY A SERVICEMAN

TABLE OF CONTENTS

1.0 SAFETY INFORMATION	3
2.0 GENERAL INFORMATION	5
2.1 Checking Product Received	5
2.2 Application	5
2.3 Dimensions	6
2.4 Electrical and Physical Data	6
2.5 Proper Installation	7
3.0 LOCATING UNIT	7
3.1 Corrosive Environment	7
3.2 Condenser Location	7
3.3 Operational Issues	8
3.4 For Condensers With Space Limitations	8
3.5 Customer Satisfaction Issues	8
3.6 Unit Mounting	8
3.7 Factory-Preferred Tie-Down Method	8
4.0 REFRIGERANT CONNECTIONS	9
4.1 Tools Required for Installing & Servicing R-410A Models	9
4.2 Specifications of R-410A	10
4.3 Quick Reference Guide for R-410-A	10
5.0 REPLACEMENT UNITS	11
6.0 INDOOR COIL	11
6.1 Location	11
7.0 INTERCONNECTING TUBING	11
7.1 Vapor and Liquid Lines	11
7.2 Maximum Length of Lines	12
7.3 Outdoor Unit Installed Above or Below Indoor Coil	12
7.4 Tubing Installation	12
7.5 Tubing Connections	15
7.6 Leak Testing	15
8.0 DUAL DRIVE COMPRESSORS	16
8.1 Compressor Identification	16
8.2 <i>Comfort Control² System™</i> Control Identification	16
8.3 <i>Comfort Control² System™</i> Control Operation	17
9.0 COMPRESSOR CRANKCASE HEAT (CCH)	17
10.0 HARD START COMPONENTS	17
11.0 HIGH AND LOW PRESSURE CONTROLS (HPC AND LPC)	17
11.1 Evacuation Procedure	18
12.0 CONDENSING UNITS EQUIPPED WITH THE <i>COMFORT CONTROL² SYSTEM™</i>	18
12.1 Control Description	18
12.2 <i>Comfort Control²</i> Control Wiring	20
12.3 <i>Comfort Control²</i> Diagnostic Codes in Dual Drive	20
12.4 <i>Comfort Control²</i> ICC Control Operation	21
12.5 Active Compressor Protection Mode	22
12.6 Test and Fault Recall Modes	24
12.7 ICC Diagnostic Codes	26
12.8 Conventional 24VAC Thermostat Control Wiring	29
12.9 Typical Non-Communicating Thermostat Wiring Diagrams	30
12.10 Diagnostic Codes in Dual Drive Condensing Units With Conventional Thermostat Wiring	31
12.11 ICC Control Operation with Conventional Thermostat Wiring	31
12.12 Active Compressor Protection Mode	32
12.13 Test and Fault Recall Modes	34
13.0 ELECTRICAL WIRING	35
13.1 Power Wiring	35
13.2 Grounding	36
13.3 Control Wiring	36
14.0 START-UP AND PERFORMANCE	36
15.0 CHECKING AIRFLOW	36
16.0 CHECKING REFRIGERANT CHARGE	37
16.1 Charging Units With R-410A Refrigerant	37
16.2 Charging By Liquid Pressure	37
16.3 Charging By Weight	37
16.4 Final Leak Testing	38
17.0 ACCESSORIES	38
17.1 Remote Outdoor Temperature Model	38
17.2 RXME-A02 Communicating 2 Wire Kit	38
18.0 TROUBLESHOOTING	38
18.1 <i>Comfort Control² System™</i> System Initial Startup	38
18.2 Replacement of <i>Comfort Control² System™</i> Control Board	39
18.3 Electrical Checks Flow Chart	40
18.4 Cooling Mechanical Checks Flow Chart	41
18.5 General Trouble Shooting Chart	42
18.6 Service Analyzer Charts	43-47
18.7 Subcooling Calculation	48
19.0 WIRING DIAGRAMS	49-50

1.0 SAFETY INFORMATION

WARNING

THESE INSTRUCTIONS ARE INTENDED AS AN AID TO QUALIFIED, LICENSED SERVICE PERSONNEL FOR PROPER INSTALLATION, ADJUSTMENT AND OPERATION OF THIS UNIT. READ THESE INSTRUCTIONS THOROUGHLY BEFORE ATTEMPTING INSTALLATION OR OPERATION. FAILURE TO FOLLOW THESE INSTRUCTIONS MAY RESULT IN IMPROPER INSTALLATION, ADJUSTMENT, SERVICE OR MAINTENANCE POSSIBLY RESULTING IN FIRE, ELECTRICAL SHOCK, PROPERTY DAMAGE, PERSONAL INJURY OR DEATH.

WARNING

THE MANUFACTURER'S WARRANTY DOES NOT COVER ANY DAMAGE OR DEFECT TO THE AIR CONDITIONER CAUSED BY THE ATTACHMENT OR USE OF ANY COMPONENTS, ACCESSORIES OR DEVICES (OTHER THAN THOSE AUTHORIZED BY THE MANUFACTURER) INTO, ONTO OR IN CONJUNCTION WITH THE AIR CONDITIONER. YOU SHOULD BE AWARE THAT THE USE OF UNAUTHORIZED COMPONENTS, ACCESSORIES OR DEVICES MAY ADVERSELY AFFECT THE OPERATION OF THE AIR CONDITIONER AND MAY ALSO ENDANGER LIFE AND PROPERTY. THE MANUFACTURER DISCLAIMS ANY RESPONSIBILITY FOR SUCH LOSS OR INJURY RESULTING FROM THE USE OF SUCH UNAUTHORIZED COMPONENTS, ACCESSORIES OR DEVICES.

WARNING

DISCONNECT ALL POWER TO UNIT BEFORE STARTING MAINTENANCE. FAILURE TO DO SO CAN CAUSE ELECTRICAL SHOCK RESULTING IN SEVERE PERSONAL INJURY OR DEATH.

WARNING

DO NOT USE OXYGEN TO PURGE LINES OR PRESSURIZE SYSTEM FOR LEAK TEST. OXYGEN REACTS VIOLENTLY WITH OIL, WHICH CAN CAUSE AN EXPLOSION RESULTING IN SEVERE PERSONAL INJURY OR DEATH.

WARNING

THE UNIT MUST BE PERMANENTLY GROUNDED. FAILURE TO DO SO CAN CAUSE ELECTRICAL SHOCK RESULTING IN SEVERE PERSONAL INJURY OR DEATH.

WARNING

TURN OFF ELECTRIC POWER AT THE FUSE BOX OR SERVICE PANEL BEFORE MAKING ANY ELECTRICAL CONNECTIONS.

ALSO, THE GROUND CONNECTION MUST BE COMPLETED BEFORE MAKING LINE VOLTAGE CONNECTIONS. FAILURE TO DO SO CAN RESULT IN ELECTRICAL SHOCK, SEVERE PERSONAL INJURY OR DEATH.

Continued on next page →

⚠ CAUTION

R-410A systems operate at higher pressures than R-22 systems. Do not use R-22 service equipment or components on R-410A equipment.

⚠ CAUTION

Only use evaporators approved for use on R-410A systems. Use of existing R-22 evaporators can introduce mineral oil to the R-410A refrigerant forming two different liquids and decreasing oil return to the compressor. This can result in compressor failure.

⚠ CAUTION

When coil is installed over a finished ceiling and/or living area, it is recommended that a secondary sheet metal condensate pan be constructed and installed under entire unit. Failure to do so can result in property damage.

⚠ CAUTION

THE COMPRESSOR HAS AN INTERNAL OVERLOAD PROTECTOR. UNDER SOME CONDITIONS, IT CAN TAKE UP TO 2 HOURS FOR THIS OVERLOAD TO RESET. MAKE SURE OVERLOAD HAS HAD TIME TO RESET BEFORE CONDEMNING THE COMPRESSOR.

⚠ CAUTION

UNIT MAY START SUDDENLY AND WITHOUT WARNING
Solid red light indicates a thermostat call for unit operation is present at the ICC control. ICC control will attempt to start unit after short cycle timer expires or when in Active Protection mode will attempt to restart unit prior to Lockout mode.

⚠ CAUTION

UNIT MAY START SUDDENLY AND WITHOUT WARNING
Solid red light indicates a thermostat call for unit operation is present at the ICC. ICC will attempt to start unit after short cycle timer expires or when in Active Protection mode will attempt to restart unit prior to Lockout mode.

⚠ CAUTION

THE TOP OF THE SCROLL COMPRESSOR SHELL IS HOT. TOUCHING THE COMPRESSOR TOP MAY RESULT IN SERIOUS PERSONAL INJURY.

⚠ CAUTION

R-410A PRESSURES ARE APPROXIMATELY 60% HIGHER THAN R-22 PRESSURES. USE APPROPRIATE CARE WHEN USING THIS REFRIGERANT. FAILURE TO EXERCISE CARE MAY RESULT IN EQUIPMENT DAMAGE, OR PERSONAL INJURY.

WARNING

THE MANUFACTURER'S WARRANTY DOES NOT COVER ANY DAMAGE OR DEFECT TO THE AIR CONDITIONER CAUSED BY THE ATTACHMENT OR USE OF ANY COMPONENTS, ACCESSORIES OR DEVICES (OTHER THAN THOSE AUTHORIZED BY THE MANUFACTURER) INTO, ONTO OR IN CONJUNCTION WITH THE AIR CONDITIONER. YOU SHOULD BE AWARE THAT THE USE OF UNAUTHORIZED COMPONENTS, ACCESSORIES OR DEVICES MAY ADVERSELY AFFECT THE OPERATION OF THE AIR CONDITIONER AND MAY ALSO ENDANGER LIFE AND PROPERTY. THE MANUFACTURER DISCLAIMS ANY RESPONSIBILITY FOR SUCH LOSS OR INJURY RESULTING FROM THE USE OF SUCH UNAUTHORIZED COMPONENTS, ACCESSORIES OR DEVICES.

MATCH ALL COMPONENTS:

- OUTDOOR UNIT
- INDOOR COIL/METERING DEVICE
- INDOOR AIR HANDLER/FURNACE
- REFRIGERANT LINES

2.0 GENERAL INFORMATION

The (-)ASL-series of condensing units are designed to operate using the *Comfort Control² System™* or traditional 24VAC controls. These units are equipped with the *Comfort Control²*. Your installation must have these components to use *Comfort Control² System™* :

- (-)ASL condensing unit equipped with the *Comfort Control² System™*
- An air handler or furnace equipped with the *Comfort Control² System™*
- A *Comfort Control²* thermostat

If your installation does not meet the above requirements, you must use traditional 24VAC controls.

This installation instruction manual contains complete instructions for installation and setup using *Comfort Control²* or conventional 24VAC controls. Please refer to the Engineering Specification Sheets for complete performance data, thermostat, and accessory listings.

The information contained in this manual has been prepared to assist in the proper installation, operation and maintenance of the air conditioning system. Improper installation, or installation not made in accordance with these instructions, can result in unsatisfactory operation and/or dangerous conditions (noise and component failure), and can cause the related warranty not to apply.

Read this manual and any instructions packaged with separate equipment required to make up the system prior to installation. Retain this manual for future reference.

To achieve optimum efficiency and capacity, the indoor cooling coils listed in the condensing unit specification sheet should be used.

2.1 CHECKING PRODUCT RECEIVED

Upon receiving unit, inspect it for any shipping damage. Claims for damage, either apparent or concealed, should be filed immediately with the shipping company. Check condensing unit model number, electrical characteristics and accessories to determine if they are correct. Check system components (evaporator coil, condensing unit, evaporator blower, etc.) to make sure they are properly matched.

2.2 APPLICATION

Before specifying any air conditioning equipment, a survey of the structure and a heat gain calculation must be made. A heat gain calculation begins by measuring all external surfaces and openings that gain heat from the surrounding air and quantifying that heat gain. A heat gain calculation also calculates the extra heat load caused by sunlight and by humidity removal.

Air conditioning systems are sized on the cooling load calculation. There are two capacities that enable the equipment to provide comfort. The first is sensible capacity.

Sensible heat is the heat energy measured on the dry bulb thermometer as it is added or removed.

The second form of heat is called **latent** or **hidden heat**. This is heat held in the humidity in the air.

A properly-sized unit removes both forms of heat, producing a comfortable living space. An oversized system cycles on and off too quickly and does not properly remove humidity, producing an uncomfortable living space. Select the indoor and outdoor equipment combination based on the manufacturer's engineering data.

After the equipment combination has been selected, satisfying both sensible and latent conditioning requirements, the system must be properly installed. Only then can the unit provide the comfort the manufacturer intends.

There are several factors that the installers must consider:

- Outdoor unit location
- System refrigerant charge
- Indoor unit blower speed
- System air balancing
- Proper equipment evacuation
- Indoor unit airflow
- Supply and return air duct design and sizing
- Diffuser and return air grille location and sizing

2.3 DIMENSIONS

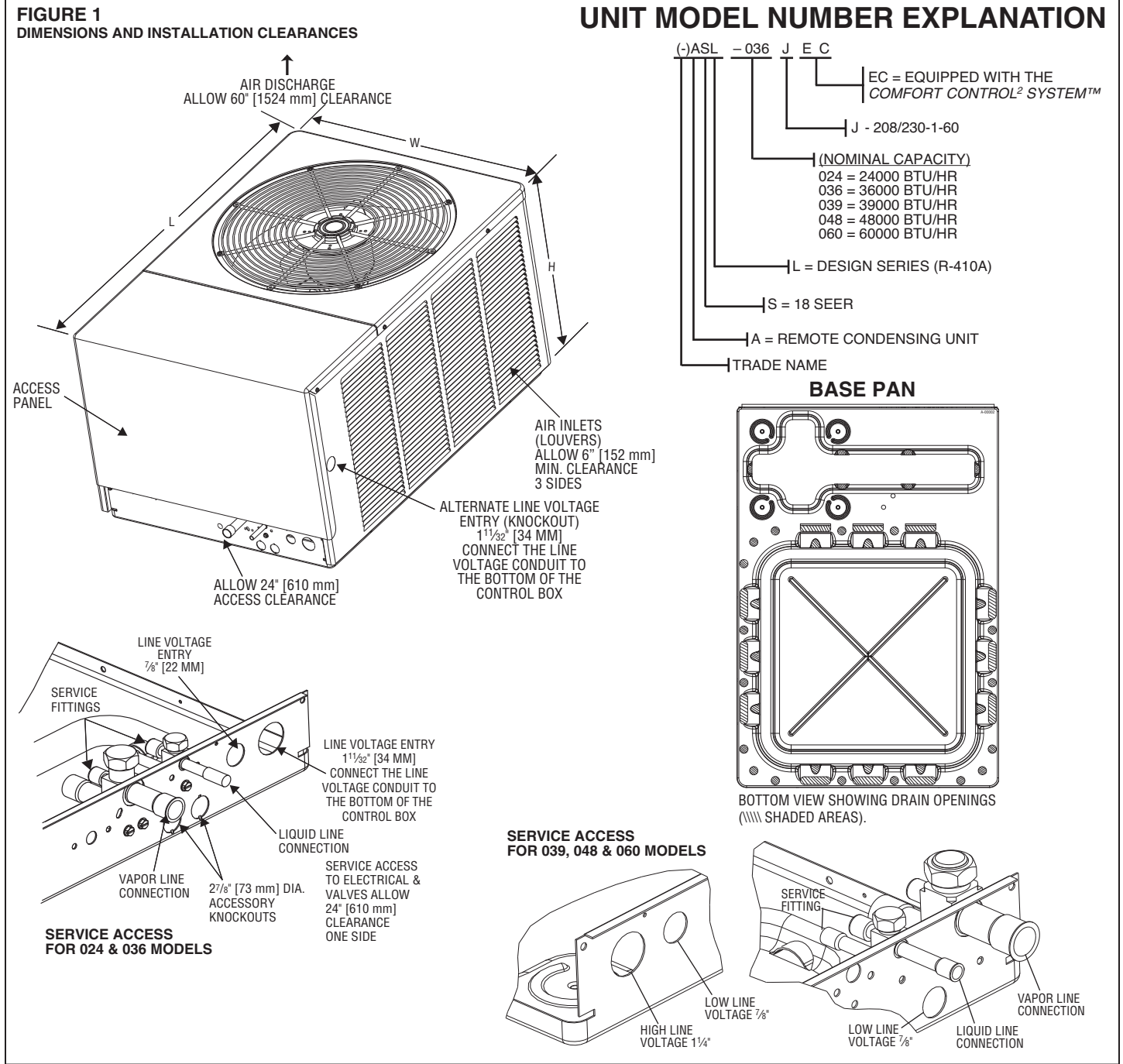

2.4 ELECTRICAL & PHYSICAL DATA

TABLE 1
(-)ASL-JEC ELECTRICAL DATA

Model Number RASL-	Phase Frequency (Hz) Voltage (Volts)	ELECTRICAL				PHYSICAL							
		Compressor		Fan Motor Full Load Amperes (FLA)	Minimum Circuit Ampacity Amperes	Outdoor Coil			Refrig. Per Circuit Oz. [g]	Weight			
		Rated Load Amperes (RLA)	Locked Rotor Amperes (LRA)			Face Area Sq. Ft. [m ²]	No. Rows	CFM [L/s]		Net Lbs. [kg]	Shipping Lbs. [kg]		
Rev. 2/24/2010													
024JEC	1-60-208/230	10.3/10.3	52	0.5	14/14	20/20	20/20	15.8 [1.47]	1	2500 [1038]	144 [4082]	236 [107]	263.5 [119.5]
036JEC	1-60-208/230	16.7/16.7	82	2.8	24/24	30/30	40/40	23.01 [2.14]	1	3400 [1321]	150 [4252]	250.5 [113.6]	314.5 [142.7]
039JEC	1-60-208/230	17.9/17.9	96	2.8	26/26	30/30	40/40	23 [2.14]	2	3500 [1321]	268 [7598]	326 [147.9]	345 [156.5]
048JEC	1-60-208/230	26.9/26.9	117	2.8	37/37	45/45	60/60	23 [2.14]	2	3500 [1321]	253 [7173]	326 [147.9]	348 [157.9]
060JEC	1-60-208/230	28.2/28.2	146	2.8	39/39	50/50	60/60	23 [2.14]	2	3500 [1321]	241 [6832]	328 [148.8]	346 [156.9]

2.5 PROPER INSTALLATION

Proper sizing and installation of this equipment is critical to achieve optimal performance. Use the information in this Installation Instruction Manual and reference the applicable Engineering Specification Sheet when installing this product.

IMPORTANT: This product has been designed and manufactured to meet ENERGY STAR® criteria for energy efficiency when matched with appropriate coil components. However, proper refrigerant charge and proper airflow are critical to achieve rated capacity and efficiency. Installation of this product should follow the manufacturer's refrigerant charging and airflow instructions. **Failure to confirm proper charge and airflow may reduce energy efficiency and shorten equipment life.**

3.0 LOCATING UNIT

3.1 Corrosive Environment

The metal parts of this unit may be subject to rust or deterioration if exposed to a corrosive environment. This oxidation could shorten the equipment's useful life. Corrosive elements include, but are not limited to, salt spray, fog or mist in seacoast areas, sulphur or chlorine from lawn watering systems, and various chemical contaminants from industries such as paper mills and petroleum refineries.

If the unit is to be installed in an area where contaminants are likely to be a problem, special attention should be given to the equipment location and exposure.

- Avoid having lawn sprinkler heads spray directly on the unit cabinet.
- In coastal areas, locate the unit on the side of the building away from the waterfront.
- Shielding provided by a fence or shrubs may give some protection, but cannot violate minimum airflow and service access clearances.
- Elevating the unit off its slab or base enough to allow air circulation will help avoid holding water against the basepan.

Regular maintenance will reduce the build-up of contaminants and help to protect the unit's finish.

WARNING

DISCONNECT ALL POWER TO UNIT BEFORE STARTING MAINTENANCE. FAILURE TO DO SO CAN CAUSE ELECTRICAL SHOCK RESULTING IN SEVERE PERSONAL INJURY OR DEATH.

- Frequent washing of the cabinet, fan blade and coil with fresh water will remove most of the salt or other contaminants that build up on the unit.
- Regular cleaning and waxing of the cabinet with a good automobile polish will provide some protection.
- A good liquid cleaner may be used several times a year to remove matter that will not wash off with water.

Several different types of protective coatings are offered in some areas. These coatings may provide some benefit, but the effectiveness of such coating materials cannot be verified by the equipment manufacturer.

3.2 CONDENSER LOCATION

Consult local and national building codes and ordinances for special installation requirements. Following location information will provide longer life and simplified servicing of the outdoor condenser.

NOTE: These units must be installed outdoors. No ductwork can be attached, or other modifications made, to the discharge grille. Modifications will affect performance or operation.

3.3 Operational Issues

- **IMPORTANT:** Locate the unit in a manner that will not prevent, impair or compromise the performance of other equipment horizontally installed in proximity to the unit. Maintain all required minimum distances to gas and electric meters, dryer vents, exhaust and inlet openings. In the absence of National Codes, or manufacturers' recommendations, local code recommendations and requirements will take precedence.
- Refrigerant piping and wiring should be properly sized and kept as short as possible to avoid capacity losses and increased operating costs.
- Locate the unit where water run off will not create a problem with the equipment. Position the unit away from the drip edge of the roof whenever possible. Units are weatherized, but can be affected by the following:
 - o Water pouring into the unit from the junction of rooflines, without protective guttering. Large volumes of water entering the heat pump while in operation can impact fan blade or motor life, and coil damage may occur to a heat pump if moisture cannot drain from the unit under freezing conditions.
 - o Freezing moisture, or sleet conditions, can cause the cabinet to ice-over prematurely and prevent heat pump operation, requiring backup heat, which generally results in less economical operation.
- Closely follow clearance recommendations on Page 6.
 - o 24" to the service panel access
 - o 60" above heat pump fan discharge (unit top) to prevent recirculation
 - o 6" to heat pump coil grille air inlets

3.4 For Units With Space Limitations FOR CONDENSERS WITH SPACE LIMITATIONS

In the event that a space limitation exists, we will permit the following clearances:

Single Unit Applications: Clearances below 6 inches will reduce unit capacity and efficiency. Do not reduce the 60-inch discharge, or the 24-inch service clearances.

Multiple Unit Applications: When multiple condenser grille sides are aligned, a 6-inch per unit clearance is recommended, for a total of 12" between two units. Two combined clearances below 12 inches will reduce capacity and efficiency. Do not reduce the 60-inch discharge, or 24-inch service, clearances.

3.5 Customer Satisfaction Issues

- The condensing unit should be located away from the living, sleeping and recreational spaces of the owner and those spaces on adjoining property.
- To prevent noise transmission, the mounting pad for the outdoor unit should not be connected to the structure, and should be located sufficient distance above grade to prevent ground water from entering the unit.

3.6 Unit Mounting

If elevating the condensing unit, either on a flat roof or on a slab, observe the following guidelines.

- The base pan provided elevates the heat pump 3/4" above the base pad.
- If elevating a unit on a flat roof, use 4" x 4" (or equivalent) stringers positioned to distribute unit weight evenly and prevent noise and vibration (see Figure 2).

NOTE: Do not block drain openings shown in Figure 1.

3.7 Factory-Preferred Tie-Down Method for Outdoor Units

IMPORTANT: The Manufacturer approved/recommended method is a guide to securing equipment for wind and seismic loads. Other methods might provide the same result, but the Manufacturer method is the only one endorsed by Manufacturer for securing equipment where wind or earthquake damage can occur. Additional information is available in the PTS (Product Technical Support) section of the Manufacturer website Rheemote.net and can be found as a listing under each outdoor model. If you do not have access to this site, your Distributor can offer assistance.

FIGURE 2
RECOMMENDED ELEVATED INSTALLATION

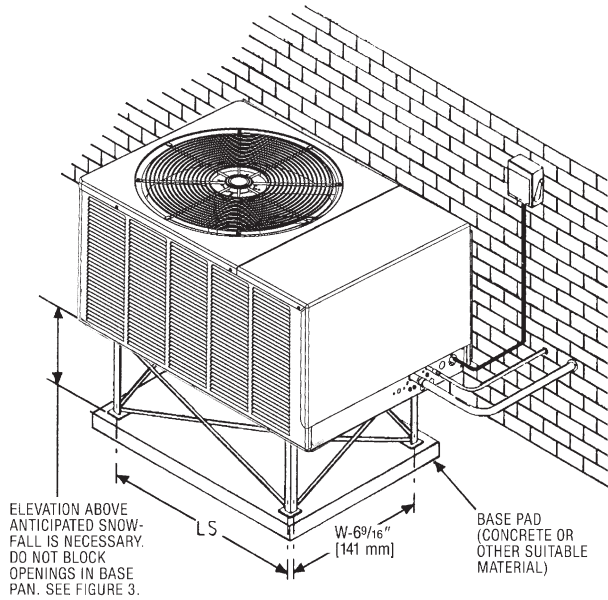

4.0 REFRIGERANT CONNECTIONS

All units are factory charged with Refrigerant 410A. All models are supplied with service valves. Keep tube ends sealed until connection is to be made to prevent system contamination.

4.1 Tools Required For Installing & Servicing R-410A Models

Manifold Sets:

- Up to 800 PSIG High side
- Up to 250 PSIG Low Side
- 550 PSIG Low Side Retard

Manifold Hoses:

- Service Pressure Rating of 800 PSIG

Recovery Cylinders:

- 400 PSIG Pressure Rating
- Dept. of Transportation 4BA400 or BW400

▲ CAUTION

R-410A systems operate at higher pressures than R-22 systems. Do not use R-22 service equipment or components on R-410A equipment.

IMPORTANT: The Rheem approved/recommended method is a guide to securing equipment for wind and seismic loads. Other methods might provide the same result, but the Rheem method is the only one endorsed by Rheem for securing equipment where wind or earthquake damage can occur. Additional information is available in the PTS (Product Technical Support) section of the Rheem website Rheemote.net and can be found as a listing under each outdoor model. If you do not have access to this site, your Distributor can offer assistance.

4.2 Specifications of R-410A:

Application: R-410A is not a drop-in replacement for R-22; equipment designs must accommodate its higher pressures. It cannot be retrofitted into R-22 heat pumps.

Physical Properties: R-410A has an atmospheric boiling point of -62.9°F and its saturation pressure at 77°F is 224.5 psig.

Composition: R-410A is an azeotropic mixture of 50% by weight difluoromethane (HFC-32) and 50% by weight pentafluoroethane (HFC-125).

Pressure: The pressure of R-410A is approximately 60% (1.6 times) greater than R-22. Recovery and recycle equipment, pumps, hoses and the like need to have design pressure ratings appropriate for R-410A. *Manifold sets need to range up to 800 psig high-side and 250 psig low-side with a 550 psig low-side retard. Hoses need to have a service pressure rating of 800 psig. Recovery cylinders need to have a 400 psig service pressure rating. DOT 4BA400 or DOT BW400.*

Combustibility: At pressures above 1 atmosphere, mixture of R-410A and air can become combustible. R-410A and air should never be mixed in tanks or supply lines, or be allowed to accumulate in storage tanks. Leak checking should never be done with a mixture of R-410A and air. Leak checking can be performed safely with nitrogen or a mixture of R-410A and nitrogen.

4.3 Quick Reference Guide For R-410A

- R-410A refrigerant operates at approximately 60% higher pressure (1.6 times) than R-22. Ensure that servicing equipment is designed to operate with R-410A.
- R-410A refrigerant cylinders are pink in color.
- R-410A, as with other HFC's is only compatible with POE oils.
- Vacuum pumps will not remove moisture from oil.
- R-410A systems are to be charged with liquid refrigerants. Prior to March 1999, R-410A refrigerant cylinders had a dip tube. These cylinders should be kept upright for equipment charging. Post March 1999 cylinders do not have a dip tube and should be inverted to ensure liquid charging of the equipment.
- Do not install a suction line filter drier in the liquid line.
- A liquid line filter drier is standard on every unit. Only manufacturer approved liquid line filter driers can be used. These are Sporlan (CW083S) and Alco (80K083S) driers. These filter driers are rated for minimum working pressure of 600 psig.
- Desiccant (drying agent) must be compatible for POE oils and R-410A.

5.0 REPLACEMENT UNITS

To prevent failure of a new condensing unit, the existing evaporator tubing system must be correctly sized and cleaned or replaced. Care must be exercised that the expansion device is not plugged. For new and replacement units, a liquid line filter drier should be installed and refrigerant tubing should be properly sized. Test the oil for acid. If positive, a suction line filter drier is mandatory.

IMPORTANT: WHEN REPLACING AN R-22 UNIT WITH AN R-410A UNIT, EITHER REPLACE THE LINE SET OR ENSURE THAT THE EXISTING LINE SET IS THOROUGHLY CLEANED OF ANY OLD OIL OR DEBRIS.

6.0 INDOOR COIL

REFER TO INDOOR COIL MANUFACTURER'S INSTALLATION INSTRUCTIONS.

IMPORTANT: The manufacturer is not responsible for the performance and operation of a mismatched system, or for a match listed with another manufacturer's coil.

NOTE: All (-)ASL units must be installed with a TXV Evaporator.

CAUTION

Only use evaporators approved for use on R-410A systems. Use of existing R-22 evaporators can introduce mineral oil to the R-410A refrigerant forming two different liquids and decreasing oil return to the compressor. This can result in compressor failure.

The thermostatic expansion valve is specifically designed to operate with R-410A. **DO NOT use an R-22 TXV or evaporator. The existing evaporator must be replaced with the factory specified TXV evaporator specifically designed for R-410A.**

6.1 Location

Do not install the indoor coil in the return duct system of a gas or oil furnace. Provide a service inlet to the coil for inspection and cleaning. Keep the coil pitched toward the drain connection.

CAUTION

When coil is installed over a finished ceiling and/or living area, it is recommended that a secondary sheet metal condensate pan be constructed and installed under entire unit. Failure to do so can result in property damage.

7.0 INTERCONNECTING TUBING

7.1 Vapor and Liquid Lines

Keep all lines sealed until connection is made.

Make connections at the indoor coil first.

Refer to Line Size Information in Tables 3, 4, 5 and 6 for correct size and multipliers to be used to determine capacity for various vapor line diameters and lengths of run. The losses due to the lines being exposed to outdoor conditions are not included.

The factory refrigeration charge in the outdoor unit is sufficient for 15 feet of interconnecting lines. The factory refrigeration charge in the outdoor unit is sufficient for the unit and 15 feet of standard size interconnecting liquid and vapor lines. For different lengths, adjust the charge as indicated below.

1/4" ± .3 oz. per foot

5/16" ± .4 oz. per foot

3/8" ± .6 oz. per foot

1/2" ± 1.2 oz. per foot

TABLE 3
VAPOR LINE CAPACITY MULTIPLIER

(-)ASL Unit Vapor Line Connection Size (inches I.D.) [mm]		024	036	039	048	060
		3/4" [19.05] I.D. Sweat	3/4" [19.05] I.D. Sweat	3/4" [19.05] I.D. Sweat	3/4" [19.05] I.D. Sweat	7/8" [22.23] I.D. Sweat
Vapor Line Run Feet [m]		Vapor Line Diameter (inches O.D.) [mm]				
		5/8" [15.88] Optional	5/8" [15.88] Optional	5/8" [15.88] Optional	5/8" [15.88] Optional	3/4" [19.05] Optional
		3/4" [19.05] Standard	3/4" [19.05] Standard	3/4" [19.05] Standard	3/4" [19.05] Standard	7/8" [22.23] Standard
25' [7.62]	Opt.	1.00	0.99	0.99	0.98	0.99
	Std.	1.00	1.00	1.00	1.00	1.00
50' [15.24]	Opt.	0.98	0.98	0.97	0.96	0.98
	Std.	1.00	1.00	0.99	0.99	0.99
75' [22.86]	Opt.	0.98	0.96	0.96	0.94	0.96
	Std.	1.00	0.99	0.99	0.98	0.99
100' [30.48]	Opt.	0.98	0.95	0.95	0.92	0.95
	Std.	N/A	N/A	N/A	N/A	N/A
125' [38.10]	Opt.	0.96	0.94	0.93	0.90	0.94
	Std.	N/A	N/A	N/A	N/A	N/A
150' [45.72]	Opt.	0.96	0.92	0.91	0.88	0.93
	Std.	N/A	N/A	N/A	N/A	N/A

NOTES:

1. Do **NOT** exceed the limits in the liquid and suction line sizing charts.
2. Do **NOT** use 7/8 OD suction lines in 2 or 4-ton applications.
3. Do **NOT** use 1-1/8 OD suction line in ANY application.
4. Line sets over 75 feet **MUST** use the optional suction line.

7.2 Maximum Length of Lines

The maximum length of interconnecting line is 150 feet. Always use the shortest length possible with a minimum number of bends. Additional compressor oil is not required for any length up to 150 feet.

NOTE: Excessively long refrigerant lines cause loss of equipment capacity.

7.3 Outdoor Unit Installed Above or Below Indoor Coil

Use the following guidelines when installing the unit:

1. Expansion Valve Coil:
 - a. The vertical separation cannot exceed the value in Tables 4, 5, and 6.
 - b. No changes are required for expansion valve coils.
2. It is recommended to use the smallest liquid line size permitted to minimize the system charge.
3. Tables 4, 5, and 6 may be used for sizing horizontal runs.

7.4 Tubing Installation

Observe the following when installing correctly sized type "L" refrigerant tubing between the condensing unit and evaporator coil:

- If a portion of the liquid line passes through a hot area where liquid refrigerant can be heated to form vapor, insulating the liquid line is required.
- Use clean, dehydrated, sealed refrigeration grade tubing.
- Always keep tubing sealed until tubing is in place and connections are to be made.
- Blow out the liquid and vapor lines with dry nitrogen before connecting to the outdoor unit and indoor coil. Any debris in the line set will end up plugging the expansion device.
- As an added precaution, a high quality filter drier is standard on R-410A units.
- Do not allow the vapor line and liquid line to be in contact with each other. This causes an undesirable heat transfer resulting in capacity loss and increased power consumption. The vapor line must be insulated.
- If tubing has been cut, make sure ends are deburred while holding in a position to prevent chips from falling into tubing. Burrs such as those caused by tubing cutters can affect performance dramatically, particularly on small liquid line sizes.

TABLE 4
(-)ASL LIQUID LINE SIZING

LIQUID LINE SIZE - OUTDOOR UNIT ABOVE INDOOR COIL

R-410A System Capacity Model	Line Size Connection Size (Inch I.D.) [mm]	Line Size (Inch O.D.) [mm]	Liquid Line Size Outdoor Unit Above Indoor Coil (Cooling Only - Does not apply to Heat Pumps) Total Equivalent Length - Feet [m]					
			25 [7.62]	50 [15.24]	75 [22.86]	100 [30.48]	125 [38.1]	150 [45.72]
			Minimum Vertical Separation - Feet [m]					
-024	3/8" [9.53]	1/4" [6.35]*	0	0	10 [3.05]	34 [10.36]	58 [17.68]	82 [24.99]
		5/16" [7.93]	0	0	0	0	0	0
		3/8" [9.52]	0	0	0	0	0	0
-036	3/8" [9.53]	5/16" [7.93]	0	0	6 [1.83]	14 [4.27]	21 [6.40]	28 [8.53]
		3/8" [9.52]*	0	0	0	0	0	0
		1/2" [12.70]	0	0	0	0	0	0
-039	3/8" [9.53]	5/16" [7.93]*	0	0	0	0	10 [3.05]	24 [7.32]
		3/8" [9.52]	0	0	0	0	0	0
		1/2" [12.70]	0	0	0	0	0	0
-048	3/8" [9.53]	5/16" [7.93]*	0	0	0	18 [5.49]	40 [12.19]	62 [18.90]
		3/8" [9.52]	0	0	0	0	0	0
		1/2" [12.70]	0	0	0	0	0	0
-060	3/8" [9.53]	3/8" [9.52]*	0	0	0	0	0	0
		1/2" [12.70]	0	0	0	0	0	0

NOTES: N/A = Application Not Recommended
 *Standard Line Size

LIQUID LINE SIZE - OUTDOOR UNIT BELOW INDOOR COIL

R-410A System Capacity Model	Line Size Connection Size (Inch I.D.) [mm]	Line Size (Inch O.D.) [mm]	Liquid Line Size Outdoor Unit Below Indoor Coil Total Equivalent Length - Feet [m]					
			25 [7.62]	50 [15.24]	75 [22.86]	100 [30.48]	125 [38.1]	150 [45.72]
			Maximum Vertical Separation - Feet [m]**					
-024	3/8" [9.53]	1/4" [6.35]*	25 [11.28]	13 [3.96]	N/A	N/A	N/A	N/A
		5/16" [7.93]	25 [14.33]	44 [13.41]	40 [12.19]	36 [10.97]	30 [9.14]	24 [7.32]
		3/8" [9.52]	25 [15.24]	48 [14.63]	47 [14.33]	46 [14.02]	45 [13.72]	43 [13.11]
-036	3/8" [9.53]	5/16" [7.93]	N/A	N/A	N/A	N/A	N/A	N/A
		3/8" [9.52]*	12 [3.66]	9 [2.74]	N/A	N/A	N/A	N/A
		1/2" [12.70]	14 [4.27]	13 [3.96]	13 [3.96]	12 [3.66]	12 [3.66]	11 [3.35]
-039	3/8" [9.53]	5/16" [7.93]*	15 [4.57]	11 [3.35]	N/A	N/A	N/A	N/A
		3/8" [9.52]	18 [5.49]	17 [5.18]	15 [4.57]	13 [3.96]	12 [3.66]	10 [3.05]
		1/2" [12.70]	20 [6.10]	19 [5.79]	19 [5.79]	19 [5.79]	18 [5.49]	18 [5.49]
-048	3/8" [9.53]	5/16" [7.93]*	25 [10.36]	24 [7.32]	N/A	N/A	N/A	N/A
		3/8" [9.52]	25 [11.89]	36 [10.97]	34 [10.36]	32 [9.75]	29 [8.84]	23 [7.01]
		1/2" [12.70]	25 [12.50]	40 [12.19]	40 [12.19]	39 [11.89]	39 [11.89]	38 [11.58]
-060	3/8" [9.53]	3/8" [9.52]*	25 [11.28]	33 [10.06]	30 [9.14]	25 [7.62]	15 [4.57]	N/A
		1/2" [12.70]	25 [11.89]	39 [11.89]	38 [11.58]	37 [11.28]	37 [11.28]	36 [10.97]

NOTES: N/A = Application Not Recommended
 *Standard Line Size

**Maximum vertical separation listed in table can be exceeded if system is charged to 8°-10°F liquid subcooling level at the indoor coil. A gauge port must be added to the liquid line near the indoor coil to measure subcooling at that point.

TABLE 5
(-)ASL SUCTION LINE SIZING

SUCTION LINE SIZE - OUTDOOR UNIT ABOVE INDOOR COIL

R-410A System Capacity Model	Line Size Connection Size (Inch I.D.) [mm]	Line Size (Inch O.D.) [mm]	Suction Line Size					
			Outdoor Unit ABOVE Indoor Coil (Cooling Only - Does not apply to Heat Pumps)					
			Total Equivalent Length - Feet [m]					
			25 [7.62]	50 [15.24]	75 [22.86]	100 [30.48]	125 [38.1]	150 [45.72]
-024	3/4" [19.05]	5/8" [15.88]	Same as Liquid Line Size Table					
		3/4" [19.05]*	NA					
		7/8" [22.23]	NA					
-036 & -039	3/4" [19.05]	5/8" [15.88]	Same as Liquid Line Size Table					
		3/4" [19.05]*	NA					
		7/8" [22.23]	NA					
-048	7/8" [22.22]	5/8" [15.88]	Same as Liquid Line Size Table					
		3/4" [19.05]*	Same as Liquid Line Size Table					
		7/8" [22.23]	NA					
-060	7/8" [22.22]	3/4" [19.05]	Same as Liquid Line Size Table					
		7/8" [22.23]*	NA					
		1-1/8" [28.58]	NA					

NOTES: Using suction line larger than shown in chart will result in poor oil return.

N/A = Application Not Recommended

*Standard Line Size

SUCTION LINE SIZE - OUTDOOR UNIT BELOW INDOOR COIL

R-410A System Capacity Model	Line Size Connection Size (Inch I.D.) [mm]	Line Size (Inch O.D.) [mm]	Suction Line Size					
			Outdoor Unit BELOW Indoor Coil (Cooling Only - Does not apply to Heat Pumps)					
			Total Equivalent Length - Feet [m]					
			25 [7.62]	50 [15.24]	75 [22.86]	100 [30.48]	125 [38.1]	150 [45.72]
-024	3/4" [19.05]	5/8" [15.88]	Same as Liquid Line Size Table					
		3/4" [19.05]*	Same as Liquid Line Size Table			NA		
		7/8" [22.23]	NA					
-036 & -039	3/4" [19.05]	5/8" [15.88]	Same as Liquid Line Size Table					
		3/4" [19.05]*	Same as Liquid Line Size Table					
		7/8" [22.23]	NA					
-048	7/8" [22.22]	5/8" [15.88]	Same as Liquid Line Size Table					
		3/4" [19.05]*	Same as Liquid Line Size Table					
		7/8" [22.23]	Same as Liquid Line Size Table			NA		
-060	7/8" [22.22]	3/4" [19.05]	Same as Liquid Line Size Table					
		7/8" [22.23]*	Same as Liquid Line Size Table					
		1-1/8" [28.58]	NA					

NOTES: Using suction line larger than shown in chart will result in poor oil return.

N/A = Application Not Recommended

*Standard Line Size

- For best operation, keep tubing run as short as possible with a minimum number of elbows or bends.
- Locations where the tubing will be exposed to mechanical damage should be avoided. If it is necessary to use such locations, the copper tubing should be housed to prevent damage.
- If tubing is to be run underground, it must be run in a sealed watertight chase.
- Use care in routing tubing and do not kink or twist. Use a good tubing bender on the vapor line to prevent kinking.
- Route the tubing using temporary hangers, then straighten the tubing and install permanent hangers. Line must be adequately supported.
- The vapor line must be insulated to prevent dripping (sweating) and prevent performance losses. Armaflex and Rubatex are satisfactory insulations for this purpose. Use 1/2" minimum insulation thickness, additional insulation may be required for long runs.
- Check Table 3 for the correct vapor line size. Check Table 4 for the correct liquid line size.

7.5 Tubing Connections

Indoor coils have only a holding charge of dry nitrogen. Keep all tube ends sealed until connections are to be made.

- Use type "L" copper refrigeration tubing. Braze the connections with the following alloys:
 - copper to copper - 5%
 - Silver alloy (no flux)
 - copper to steel or brass - 35%
 - silver alloy (with flux)
- Be certain both refrigerant shutoff valves at the outdoor unit are closed.
- Clean the inside of the fittings and outside of the tubing with steel wool or sand cloth before soldering. Always keep chips, steel wool, dirt, etc., out of the inside when cleaning.
- Assemble tubing part way into fitting. Apply flux all around the outside of the tubing and push tubing into stop. This procedure will keep the flux from getting inside the system.
- Remove the cap and schrader core from service port to protect seals from heat damage.
- Use an appropriate heatsink material around the copper stub and the service valves before applying heat.
- **IMPORTANT:** Do not braze any fitting with the TEV sensing bulb attached.
- Braze the tubing between the outdoor unit and indoor coil. Flow dry nitrogen into a service port and through the tubing while brazing.
- After brazing – use an appropriate heatsink material to cool the joint and remove any flux residue.
- The service valves are not backseating valves. To open the valves, remove the valve cap with an adjustable wrench. Insert a 3/16" or 5/16" hex wrench into the stem. Back out counterclockwise.
- Replace the valve cap finger tight then tighten an additional 1/2 hex flat for a metal-to-metal seal.

7.6 Leak Testing

- Pressurize line set and coil through service fittings with dry nitrogen to 150 PSIG maximum. Leak test all joints using liquid detergent. If a leak is found, recover pressure and repair.

WARNING

DO NOT USE OXYGEN TO PURGE LINES OR PRESSURIZE SYSTEM FOR LEAK TEST. OXYGEN REACTS VIOLENTLY WITH OIL, WHICH CAN CAUSE AN EXPLOSION RESULTING IN SEVERE PERSONAL INJURY OR DEATH.

8.0 DUAL DRIVE COMPRESSORS

The -039, -048, & -060 condensing units contain two compressors to deliver maximum efficiency and comfort. The Dual Drive Compressors are sized to increase run times at first stage operation (partial capacity). When additional capacity is needed, a two stage thermostat energizes both compressors to deliver full rated capacity.

8.1 Compressor Identification

The individual compressors are identified as Compressor A and Compressor B. When facing the access panel, Compressor A is on the left and Compressor B is on the right. (See Figure 4.)

FIGURE 4
DUAL DRIVE COMPRESSORS

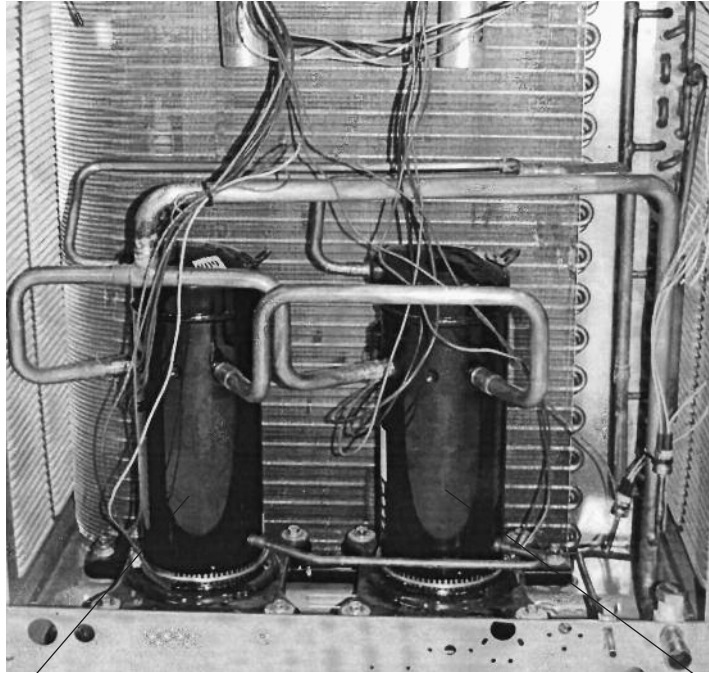

COMPRESSOR A

COMPRESSOR B

8.2 Comfort Control² System™ Control Identification

The Dual Drive condensing units use one (1) serial communicating control per compressor. There is a label in the control box that identifies each control/compressor combination. When facing the access panel, Compressor A is controlled by the left-hand board and Compressor B is controlled by the right-hand board.

FIGURE 5



8.3 Comfort Control² System™ Control Operation

A Dual Drive unit has two controls instead of a single control. The controls are the same as any residential communicating control except the secondary control dip-switches (SW5) should be in the off position. Therefore, the features such as fault recall and the operation of the test button are the same as any JEC control.

The two controls are identical and interchangeable, but the memory cards that attach to the controls are not interchangeable. This allows the controls to be swapped for troubleshooting if one of the controls is suspected of being defective. If the controls are swapped, it is important to keep the memory cards in the proper locations. Do not cut the tethers on the memory cards!

8.4 Lead/Lag

Tandem compressor ASL units now have a Lead/Lag functionality built into the control software. The purpose of Lead/Lag is to average the runtime of the compressors to give the homeowner the greatest compressor life possible. Upon receiving a first stage call, the primary compressor control (the control on the left as you face the control box) will alternate which compressor services the call. An example of Lead/Lag is: if compressor A is energized on one first stage call, compressor B would normally service the next first stage call.

9.0 COMPRESSOR CRANKCASE HEAT (CCH)

CCH is standard on these models due to refrigerant migration during the off cycle that can result in a noisy start up.

Crankcase Heater Operation:

Supplemental Crankcase heat is required to prevent refrigerant migration in systems with relatively high system refrigerant charges. Each Dual Drive compressor has its own crankcase heater.

The crankcase heater control is integrated into the *Comfort Control² System™* and is designed for maximum energy savings.

Summary of operation:

- The crankcase heater is off whenever the compressor is running.
- Once the compressor turns off, the crankcase heater control (CCH) begins the two-hour timer countdown.
- If the compressor stays off for two hours, the CCH turns on the crankcase heater.

All heaters are located on the lower half of the compressor shell. Its purpose is to drive refrigerant from the compressor shell during long off cycles, thus preventing damage to the compressor during start-up.

At initial start-up or after extended shutdown periods, make sure the heater is energized for at least 12 hours before the compressor is started. (Disconnect switch on and wall thermostat off.)

10.0 HARD START COMPONENTS

Factory-installed start components are standard on all models.

11.0 HIGH AND LOW PRESSURE CONTROLS (HPC AND LPC)

These controls keep the compressor from operating in pressure ranges which can cause damage to the compressor. Both controls are in the low voltage control circuit.

High pressure control (HPC) is an automatic-reset which opens near 610 PSIG and closes near 420 PSIG.

The low pressure control (LPC) is an automatic-reset which opens near 50 PSIG and closes near 95 PSIG.

NOTE: HPC and LPC are monitored by the *Comfort Control² System™*. See Section 12.0.

⚠ CAUTION

THE COMPRESSOR HAS AN INTERNAL OVERLOAD PROTECTOR. UNDER SOME CONDITIONS, IT CAN TAKE UP TO 2 HOURS FOR THIS OVERLOAD TO RESET. MAKE SURE OVERLOAD HAS HAD TIME TO RESET BEFORE CONDEMNING THE COMPRESSOR.

11.1 Evacuation Procedure

Evacuation is the most important part of the entire service procedure. The life and efficiency of the equipment is dependent upon the thoroughness exercised by the serviceman when evacuating air and moisture from the system.

Air in the system causes high condensing temperatures and pressure, resulting in increased power input and non-verifiable performance.

Moisture chemically reacts with the refrigerant and oil to form corrosive hydrofluoric and hydrochloric acids. These attack motor windings and parts, causing breakdown.

After the system has been leak checked and proven sealed, connect the vacuum pump and evacuate system to 500 microns. The vacuum pump must be connected to both the high and low sides of the system through adequate connections. Use the largest size connections available since restrictive service connections may lead to false readings because of pressure drop through the fittings.

IMPORTANT: Compressors (especially scroll type) should never be used to evacuate the air conditioning system because internal electrical arcing may result in a damaged or failed compressor.

With thermostat in the "Off" position, turn the power on to the furnace and the heat pump. Start the heat pump and the furnace with the thermostat. Make sure the blower is operating.

12.0 CONDENSING UNITS EQUIPPED WITH THE *COMFORT CONTROL² SYSTEM™*

Comfort Control² is the next generation of the Integrated Compressor Control (ICC) and is an integral part of the *Comfort Control² System™* with the following features:

12.1 Control Description (see Figure 4)**Dual 7-Segment LED**

- Displays status and diagnostic codes (See Status and Diagnostic Description)
- Displays diagnostic/fault recall (See Test Mode/Fault Recall)

Red LED (Y1)

- Y1 red LED (solid on) indicates Y1 call from thermostat is present

⚠ CAUTION**UNIT MAY START SUDDENLY AND WITHOUT WARNING**

Solid red light indicates a thermostat call for unit operation is present at the ICC control. ICC control will attempt to start unit after short cycle timer expires or when in Active Protection mode will attempt to restart unit prior to Lockout mode.

Line Voltage Connector

- Line voltage is connected to control board at lug terminals L1 & L2
 - Maximum wire size accepted is 6 AWG copper wire
 - # 4 – 6 AWG 45 in/lbs
 - # 8 AWG 40 in/lbs
 - # 10 – 14 AWG 35 in/lbs
- (Check wire terminations annually)

Compressor Control (K2)

- Sealed single pole compressor relay switch with optical feedback feature (arc detection)

Thermostat Connector (E2)

- R – 24VAC from the indoor unit 24VAC transformer (40 VA minimum)
- C – 24VAC Common from the indoor unit 24VAC transformer
- 1-Data: System Communications Line 1
- 2-Data: System Communications Line 2

Low Volt Fuse

- If required replace with 3 A automotive ATC style blade fuse

Low Pressure Control (LPC Input)

- Low-pressure control is factory installed
- Low pressure control is an automatic resetting device

High Pressure Control (HPC Input)

- High-pressure control is factory installed
- High pressure control is an automatic resetting device

Ambient Temperature Sensor (included with all applications)

- Included with all applications

TEST and SW2 Buttons

- TEST and SW2 buttons used to enter Test and Fault Recall Mode

Memory Card

- The memory card stores all unit information.
- The unit information is called shared data.
- The shared data is all the information needed for proper unit operation.

FIGURE 6
COMFORT CONTROL² BOARD

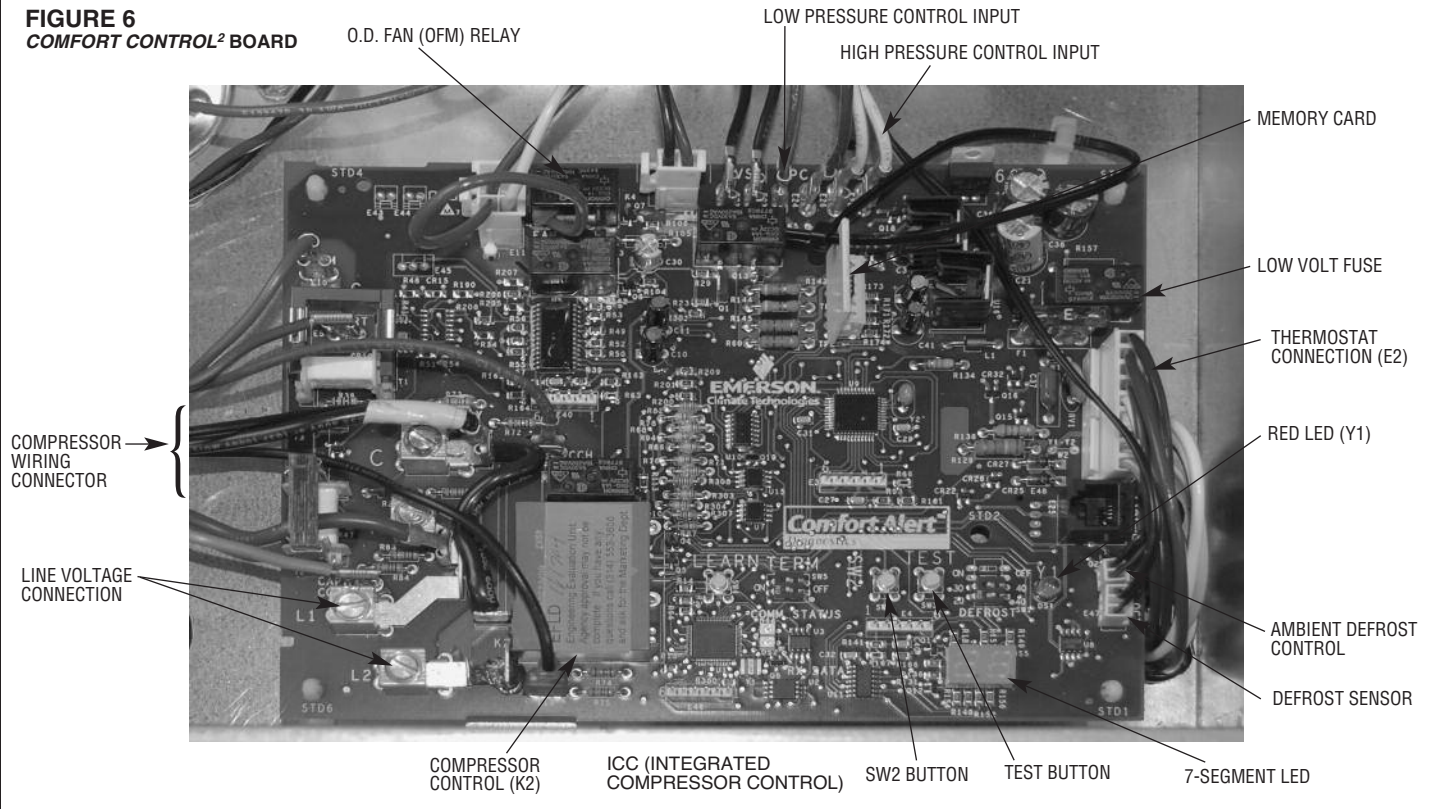

12.2 Comfort Control² System™ Control Wiring

An HVAC system equipped with *Comfort Control² System™* consists of:

- Heat pump or condensing unit equipped with *Comfort Control²*
- Air handler or furnace equipped with *Comfort Control²*
- *Comfort Control²* thermostat

The four 18AWG low voltage control wires must be installed from the thermostat to the indoor unit and from indoor unit to the outdoor unit. The wire length between the thermostat and indoor unit should not be greater than 100 feet. The wire length between the indoor unit and outdoor unit should not be greater than 125 feet.

IMPORTANT: If the installed system does not meet these requirements, the system must be wired using traditional control wiring, reference Section 12.7 Conventional 24VAC Thermostat Control Wiring.

Serial communications require four (4) control wires for unit operation:

- R – 24VAC
- C – 24VAC common
- 1 – Data wire 1
- 2 – Data wire 2

Note: *Comfort Control² System™* requires 18 AWG thermostat wire.

Note: TERM dipswitches should be in ON position.

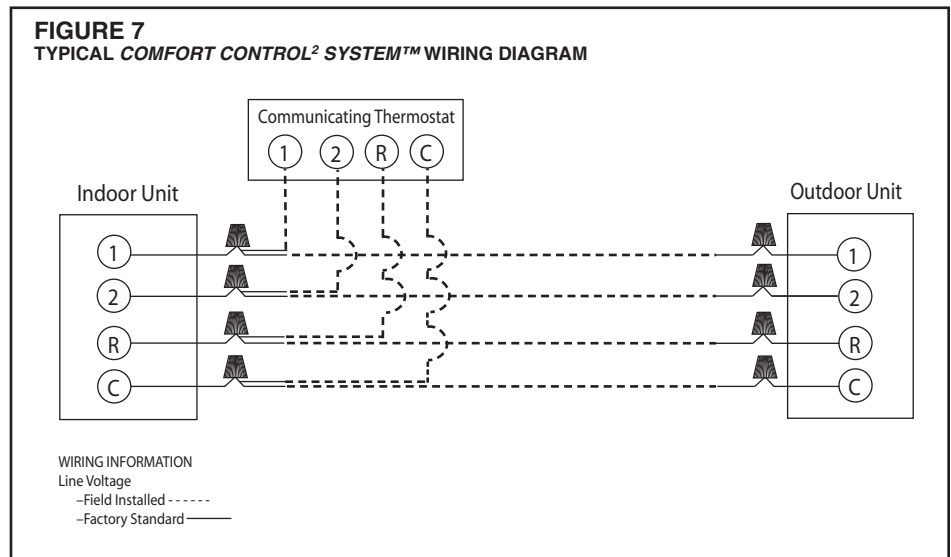

If the low voltage control wiring is run in conduit with the power supply, Class I insulation is required. Class II insulation is required if run separate. Low voltage wiring may be run through the insulated bushing provided in the 7/8 hole in the base panel, up to and attached to the pigtails from the bottom of the control box. Conduit can be run to the base panel if desired by removing the insulated bushing.

The serial communicating air handler or serial communicating furnace transformer is equipped with a 24 volt, 50 VA transformer for proper system operation. See the wiring diagram in Figure 5 for reference.

12.3 Comfort Control² System™ Diagnostic Codes in Dual Drive Condensing Units

Comfort Control² System™ controls for both compressors are connected to the serial communicating network via Data Wire 1 and Data Wire 2. Each *Comfort Control² System™* control board maintains separate fault history for the compressor it controls. Fault codes for both compressors can be retrieved using a service tool or via the installer menus.

12.4 Comfort Control² ICC Control Operation

Installation Verification

- 24V AC power on R&C must be present at the ICC for it to operate
- Line voltage must be present at the ICC for the compressor and the outdoor fan to operate
- The ICC displays a “0” for standby mode. Standby mode indicates line voltage and 24VAC are present at the ICC and there is not a command for unit operation from the serial communicating thermostat.



Zero (0) displayed
The unit is in standby

Command for Compressor Operation (Y1 LED)

- If a command for compressor operation is received by the ICC (first stage/second stage cooling or first stage/second stage heating), the red Y1 LED will illuminate.
- The ICC has an on/off fan delay of one (1) second for each stage of heating or cooling.
- The ICC ignores the low pressure control for the first 90 seconds of compressor operation.
- The dual 7-segment LED displays five (5) operational status codes.

1) **First Stage Cooling Operation** – When the ICC receives a command for first stage cooling operation, a lower case “c” is displayed on the dual 7-segment LEDs.



Lower case “c” indicates first stage cooling operation

2) **Second Stage Cooling Operation** – When the ICC receives a command for second stage cooling operation, an upper case “C” is displayed on the dual 7-segment LEDs.



Upper case “C” indicates second stage cooling operation

3-minute Anti-short Cycle Timer

- The ICC has a built in 3-minute time delay between compressor operations to protect the compressor against short cycling. The dual 7-segment LEDs will flash “c” or “C” while the short cycle timer is active and a command for unit operation is received.



Flashing lower case c
A command for first stage cooling has been received



Flashing upper case C
A command for second stage cooling has been received

- The 3-minute time delay can be bypassed when a command for compressor operation is present by pressing the TEST button for 1 second and releasing. The compressor will begin operation and the dual 7-segment will stop flashing.

30 Second Minimum Run Timer

- The ICC has a built in 30 second minimum unit run time. If a command for compressor operation is received by the ICC and the command is removed, the compressor will continue to operate for 30 seconds. The dual 7-segment LEDs will flash “c” or “C” while the minimum run timer is active.

1 Second Compressor/Fan Delay

- The ICC starts/stops the outdoor fan one (1) second after the start/stop of the compressor upon a command for compressor operation to minimize current inrush and/or voltage drop.

12.5 Active Compressor Protection Mode

- The ICC actively protects the compressor from harmful operation during a fault condition.
- When the ICC detects a condition that could damage the compressor, the ICC will enter active protection mode and lockout compressor operation
- The condition causing active protection must be resolved then the ICC can be reset to restart the system.
- There are five (5) active protection modes:

1) Low Pressure Control Lockout

- The ICC will display a flashing “L” followed by a flashing 21 when a low pressure control lockout occurs.
- The ICC addresses low pressure control faults differently depending on the mode of unit operation (cooling or heating mode).

Active Protection – Code L21 – Open low pressure control

Cooling Mode

- If the LPC opens three (3) times during the same command for cooling operation, the ICC will lockout the compressor to keep it from continuing to operate and flash a “L” on the dual 7-segment LEDs followed by a “21”.

IMPORTANT: This mode of active protection must be manually reset.

2) High Pressure Control Lockout

- If the HPC opens three (3) times during the same command for unit operation, the ICC will lockout the compressor to keep it from continuing to operate and flash a “L” on the dual 7-segment LEDs followed by a “29”.

Active Protection – Code L29 – Open high pressure control

IMPORTANT: This mode of active protection must be manually reset.

3) Locked Rotor

- The ICC will display a flashing “L” followed by a flashing “04” when a locked rotor condition occurs.

Active Protection – Code L4 – Locked rotor

If the ICC detects the compressor has run less than 15 seconds before the protector tripped for four (4) consecutive starts during the same command for unit operation, the ICC will lockout the compressor to keep it from continuing to operate and flash a “L” on the dual 7-segment LEDs followed by a “04”.

IMPORTANT: This mode of active protection must be manually reset.

4) Compressor Protector Trip

- If ICC detects a protector trip it will display a “P”. If protector doesn’t reset within 4 hours, the ICC display will change to “5”.

Compressor Protector – Code P – Protector Trip

5) Open Start Circuit Lockout

- The ICC will display a flashing “L” followed by a flashing “06” when an open start circuit condition occurs.

Active Protection – Code L6 – Compressor open start circuit

If the ICC lockouts L6 and L7 detect current in the run circuit without current present in the start circuit, the ICC will lockout the compressor to keep it from continuing to operate and flash a “L” on the dual 7-segment LEDs followed by a “06”.

IMPORTANT: This mode of active protection must be manually reset.

6) Open Run Circuit Lockout

- The ICC will display a flashing “L” followed by a flashing “07” when an open start circuit condition occurs.

Active Protection – Code L7 – Compressor open run circuit

If the ICC detects current in the start circuit without current present in the run circuit, the ICC will lockout the compressor to keep it from continuing to operate and flash a “L” on the dual 7-segment LEDs followed by a “07”.

IMPORTANT: This mode of active protection must be manually reset.

Exiting Active Compressor Protection Lockout

There are three methods to reset the ICC after an active protection lockout:

- 1) Cycle the line voltage to the unit
- 2) Cycle 24VAC to the ICC (remove the R or C connection to the ICC)
- 3) Push the TEST button down with an insulated probe for one (1) second and release

Note: The ICC will attempt to start the unit when the TEST button is pressed and released

Note: The preferred method of resetting the ICC is to push the TEST button down for one (1) second.

12.6 Test and Fault Recall Modes

Test Mode (Test Button on the ICC)

- Enter TEST mode by pressing the TEST button with an insulated probe for one (1) second and release.
- The TEST mode causes the ICC to do the following
 - 1) Resets the ICC from active protection lockout mode
 - 2) Bypasses the 3-minute anti-short cycle timer
 - 3) Energizes the unit without a command for unit operation
- If the 3-minute anti-short cycle timer or 30 second minimum run timer is active (a flashing “c”, “C”, “h”, or “H” is displayed on the dual 7-segment LEDs) and a command for unit operation is present, TEST mode causes:
 - 1) A “t” to display momentarily on the dual 7-segment display



Lower case “t”

- 2) The compressor will start and the outdoor fan will operate
- 3) The display will change to a steady “c” or “C” to show the current command for unit operation.

Note: If a command for unit operation is present at the end of TEST mode will cause the unit to continue to operate.

- If no command for unit operation is present, TEST mode causes
 - 1) A steady “t” appears on the dual 7-segment LEDs
 - 2) The compressor will start
 - 3) The compressor will turn off after 5-seconds.

Note: Entering TEST mode without a command for unit operation will cause the compressor to run 5-seconds.

Fault Recall Mode (TEST and SW2 Buttons)

- Enter **FAULT RECALL** mode by pressing the **TEST** and **SW2** buttons at the same time with insulated probes for one (1) second and release.
- When entering and exiting **FAULT RECALL** mode the top and bottom segments of the dual 7-segment LEDs will illuminate.



Fault Recall Mode – the top and bottom segments on the right side are illuminated



- When entering **FAULT RECALL** mode, the ICC will automatically scroll through stored faults on the dual 7-segment LEDs.
- Each fault is displayed one time with the top right hand segment of the dual 7-segment display activated between faults.
- Each fault is displayed with the most recent fault displayed first.

- A maximum of six individual faults can be stored
- A maximum of three consecutive identical faults are stored.
- A "0" will be displayed with no faults are stored
- The ICC will automatically exit the **FAULT RECALL** mode after displaying stored faults

Clear Fault History (TEST and SW2 Buttons)

- Clear FAULT HISTORY by pressing both TEST and SW2 button for five (5) seconds with insulated probes and release.
- The top and bottom segments of the dual 7-segment LEDs flash to indicate the history has been cleared.



Fault history is cleared with the top and bottom LED segments flash













NOTE: The memory card for the system has specific shared data for this system. The memory card is attached to the control box with a tether. The tether has an identification tag that can be used to identify the memory card. For the system data faults d1 through d8 reference the label on the memory card tether.

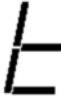







COMFORT CONTROL² SYSTEM™ CONTROL WIRING AND CONVENTIONAL THERMOSTAT WIRING ICC DIAGNOSTIC CODES

ICC Diagnostic Codes

Descriptions of the ICC diagnostic codes are provided below:

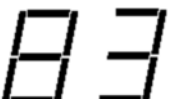
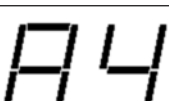
Dual 7-Segment LEDs Display Code	Diagnostic Description	Status/Possible Cause – Troubleshooting Information
	0 – Standby No command for unit operation	Normal operation
	c - First Stage Cooling Unit has received a command for first stage cooling	Normal operation
 FLASHING	c - Anti-short cycle timer (3 minutes) or Minimum run timer (30 seconds) active	<ul style="list-style-type: none"> • The unit has received a command for first stage cooling during an active anti-short cycle timer or minimum run timer. • Wait until unit timer has expired or press the TEST button to defeat short cycle delay.
	C - Second Stage Cooling Unit has received a command for second stage cooling	Normal operation
 FLASHING	C - Anti-short cycle timer (3 minutes) or Minimum run timer (30 seconds) active	<ul style="list-style-type: none"> • The unit has received a command for second stage cooling during an active anti-short cycle timer or minimum run timer. • Wait unit timer has expired or press the TEST button to defeat short cycle delay.
	t - Test Mode	The ICC is in TEST mode
	P – Protector Trip A command for compressor operation is present but no current is measured to the compressor	<ul style="list-style-type: none"> • Motor protector open • Line voltage disconnected
	01 – Long Run Time (Compressor) The compressor has continuously run for more than 18 hours in the cooling mode.	<ul style="list-style-type: none"> • Low refrigerant charge • Air ducts have substantial leakage • Dirty indoor air filter • Dirty outdoor coil
	02 – High Side Fault Compressor limit has opened four (4) times within a call for operation	<ul style="list-style-type: none"> • Outdoor coil is dirty (cooling mode) • Outdoor fan is not running (cooling mode) • Dirty indoor coil or filter (heating mode) • Indoor blower is not running (heating mode) • Liquid line restriction • Excessive refrigerant charge
	03 – Short Cycling The ICC detects the run time for the past four (4) compressor cycles is less than three (3) minutes each.	<ul style="list-style-type: none"> • Check thermostat wire connections (R, C, 1, & 2) • Check thermostat location in zone (too close to discharge grill)
	L4 – Locked Rotor The ICC detects four (4) consecutive protector trips have occurred and the run time before each trip is less than 15 seconds	<ul style="list-style-type: none"> • Bad run capacitor • Low line voltage • Excessive refrigerant in compressor • Seized bearings in compressor

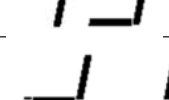
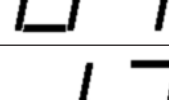
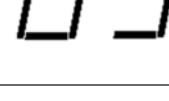
Dual 7-Segment LEDs Display Code	Diagnostic Description	Status/Possible Cause – Troubleshooting Information
05	<p>05 – Open circuit (Compressor will not Run)</p> <ul style="list-style-type: none"> The ICC has received a command for unit operation but no current is present in the start and run circuits The ICC will attempt to restart the unit every five (5) minutes for four (4) attempts. After that, the ICC will attempt a restart every twenty (20) minutes for up to four (4) hours. The ICC has had a protector trip for longer than 4 hours. 	<ul style="list-style-type: none"> Check for damaged, miswired, or wrong run capacitor Check for broken wires, loose connectors, or miswired compressor Check compressor windings for continuity Check for open compressor internal protector No retries, contactor remains closed (infinite retries)
06	<p>06 – Compressor Open Start Circuit</p> <p>The ICC detects current in the Run circuit but not in the Start circuit of the compressor</p>	<ul style="list-style-type: none"> Check for damaged, miswired, or wrong run capacitor Check for broken wires, loose connectors, or miswired compressor Check compressor windings for continuity
L 06	<p>06 – Compressor Open Start Circuit</p> <p>The ICC detects current in the Run circuit but not in the Start circuit of the compressor five times, 4 retries in one compressor call</p>	<ul style="list-style-type: none"> Check for damaged, miswired, or wrong run capacitor Check for broken wires, loose connectors, or miswired compressor Check compressor windings for continuity
L 07	<p>07 – Compressor Open Run Circuit</p> <p>The ICC detects current in the Start circuit but not in the Run circuit of the compressor</p>	<ul style="list-style-type: none"> Check for damaged, miswired, or wrong run capacitor Check for broken wires, loose connectors, or miswired compressor Check compressor windings for continuity
L7	<p>07 – Compressor Open Run Circuit</p> <p>The ICC detects current in the Start circuit but not in the Run circuit of the compressor four (4) times in one compressor call (4 retries)</p>	<ul style="list-style-type: none"> Check for damaged, miswired, or wrong run capacitor Check for broken wires, loose connectors, or miswired compressor Check compressor windings for continuity
09	<p>09 – Low Secondary Volts</p> <p>The secondary voltage at R and C is below 18VAC</p>	<ul style="list-style-type: none"> Control transformer overloaded Low line voltage
21	<p>21 – Low Pressure Control Open</p> <p>The ICC detects the LPC is open.</p> <p>Note: The low pressure control is ignored for the first 90 seconds of compressor operation</p>	<ul style="list-style-type: none"> Unit has low refrigerant charge Indoor coil is frozen (cooling mode) Dirty indoor coil or filter (cooling mode) Indoor blower is not running (cooling mode) Outdoor coil is frozen (heating mode) Expansion valve is not operating correctly
L 21 FLASHING	<p>L21 – Active Protection Low Pressure Control Trip</p> <p>LPC has opened 3 times in the same cooling operation, the ICC has locked out the compressor to protect it. ICC alternately flashes L and 21</p>	<p>(see 21 above)</p>
27	<p>27 – Low Line Voltage or No Line Voltage Fault</p>	<ul style="list-style-type: none"> Check incoming line voltage to the disconnect and unit Check wiring connections

Dual 7-Segment LEDs Display Code	Diagnostic Description	Status/Possible Cause – Troubleshooting Information
	28 – High Line Voltage Fault	<ul style="list-style-type: none"> • Check line voltage
	29 – High Pressure Control Open The ICC detects the HPC is open	<ul style="list-style-type: none"> • Outdoor coil is dirty (cooling mode) • Outdoor fan is not running (cooling mode) • Dirty indoor coil or filter (heating mode) • Indoor blower is not running (heating mode) • Liquid line restriction • Excessive refrigerant charge
	L29 – Active Protection High Pressure Control Trip LPC has opened 3 times in the same cooling operation, the ICC has locked out the compressor to protect it. ICC alternately flashes L and 29	(see 29 above)
	30 – Fuse Open The ICC detects the on-board fuse is open	<ul style="list-style-type: none"> • The 3-amp fuse on the ICC is open. • Low voltage wiring at R and C is damaged or miswired.
	80 – Low Air Flow The ICC detects that the indoor unit is not providing the minimum airflow requirements.	<ul style="list-style-type: none"> • Misapplied/wrong indoor air mover – replace with properly sized unit.
	83 – Condenser Coil Temperature Fault The sensor detects an abnormally low or high coil temperature	<ul style="list-style-type: none"> • Replace the sensor • Check sensor is installed correctly on control
	84 – Outdoor Ambient Temperature Fault The sensor detects an abnormally low or high outdoor ambient temperature	<ul style="list-style-type: none"> • Check unit placement – If the outdoor unit is in a high temperature area, wait until the ambient temperature drops and check sensor reading. • Replace the sensor. • Check sensor is installed correctly on control
	93 – Internal Control Fault The control is not functioning properly.	<ul style="list-style-type: none"> • Check control for proper system operation. • Replace control
	d1 – No Shared Data	<ul style="list-style-type: none"> • Replace memory card with correct system information.
	d3 – Airflow CFM Mismatch The indoor air mover (air handler/furnace) cannot supply the required airflow for proper system operation	<ul style="list-style-type: none"> • Misapplied/wrong indoor air mover – replace with properly sized air handler/furnace.
	d4 – (Device) Memory Card Invalid for Device The data in the memory card inserted into the control board does not match the data in the control.	<ul style="list-style-type: none"> • Check memory card to ensure it matches device • Check if memory card is present
	d8 – Old Shared Data System data is obsolete	<ul style="list-style-type: none"> • If system will not operate, order new memory card to update system information.

12.8 Conventional 24VAC Thermostat Control Wiring

The (-)ASL series of heat pumps allow the installer to use conventional 24VAC control wiring and a conventional thermostat for proper unit operation.

IMPORTANT: The preferred method of unit installation and operation is by serial communications. Serial communications allow access to the fault history of the system. This diagnostic information is not available when the (-)ASL unit is using a conventional thermostat. Reference section 12.2 *Comfort Control*² Control Wiring.

Thermostat control wiring requires a minimum of four (4) wires for proper unit operation:

- R – 24VAC
- C – 24VAC common
- Y1 – First stage operation
- Y2 – Second stage operation

Optional wiring:

- L – ICC fault information

If the low voltage control wiring is run in conduit with the power supply, Class I insulation is required. Class II insulation is required if run separate. Low voltage wiring may be run through the insulated bushing provided in the 7/8 hole in the base panel, up to and attached to the pigtails from the bottom of the control box. Conduit can be run to the base panel if desired by removing the insulated bushing.

A thermostat and a 24-volt, 40VA minimum transformer are required for the control circuit of the condensing unit. The furnace or the air handler transformer may be used if sufficient. See the wiring diagram for reference. Use Table 6 to size the 24-volt control wirings.

L Terminal Output

- Flash 1 – Compressor running extremely long run cycle or low pressure
- Flash 2 – High pressure control trip
- Flash 3 – Unit short cycling
- Flash 4 – Locked rotor
- Flash 5 – Compressor will not run, open circuit
- Flash 6 – Open start circuit
- Flash 7 – Open run circuit
- Flash 8 – Control mis-operation
- Flash 9 – Low control voltage

Thermostat Load - Amps	SOLID COPPER WIRE - AWG.					
	3.0	16	14	12	10	10
2.5	16	14	12	12	10	10
2.0	18	16	14	12	12	10
	50	100	150	200	250	300
	Length of Run - Feet (1)					

(1) Wire length equals twice the run distance.
NOTE: Do not use control wiring smaller than No. 18 AWG between thermostat and outdoor unit.

FIGURE 8
TYPICAL 2-STAGE THERMOSTAT: CONDENSING UNIT WITH ELECTRIC HEAT

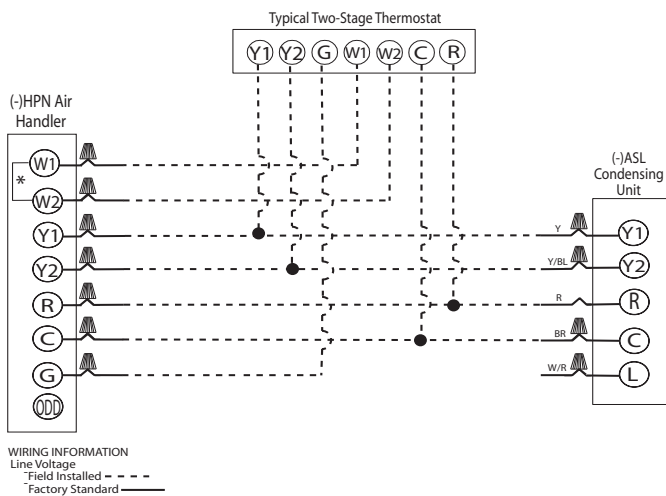

FIGURE 9
TYPICAL 2-STAGE THERMOSTAT: CONDENSING UNIT WITH ELECTRIC HEAT USING A HUMIDISTAT FOR DEHUMIDIFICATION*

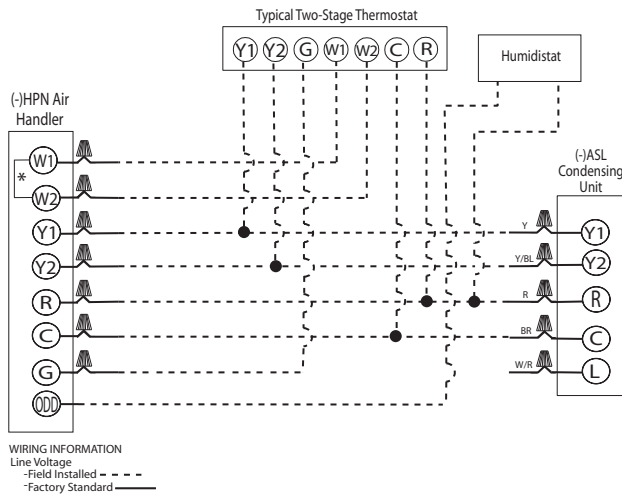

FIGURE 10
TYPICAL TWO-STAGE THERMOSTAT: CONDENSING UNIT WITH ELECTRIC HEAT USING A TWO-STAGE THERMOSTAT WITH DEHUMIDIFICATION*

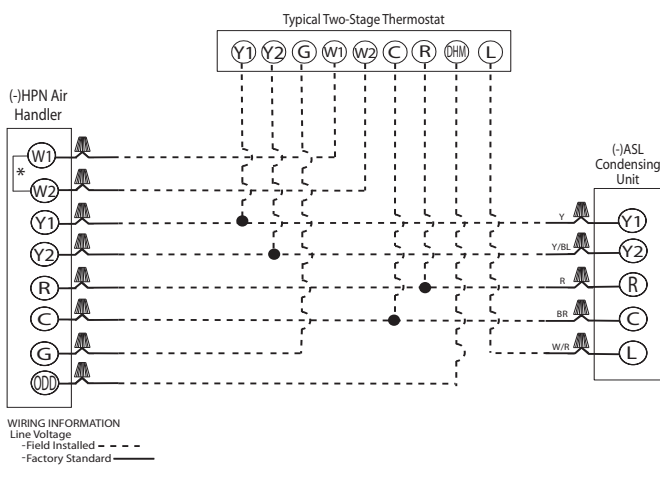
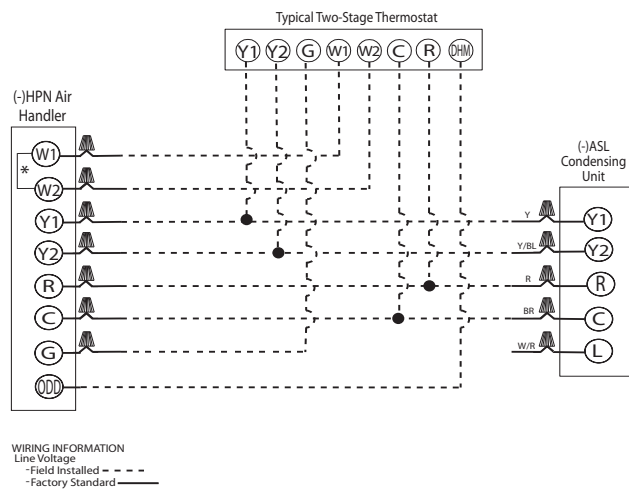
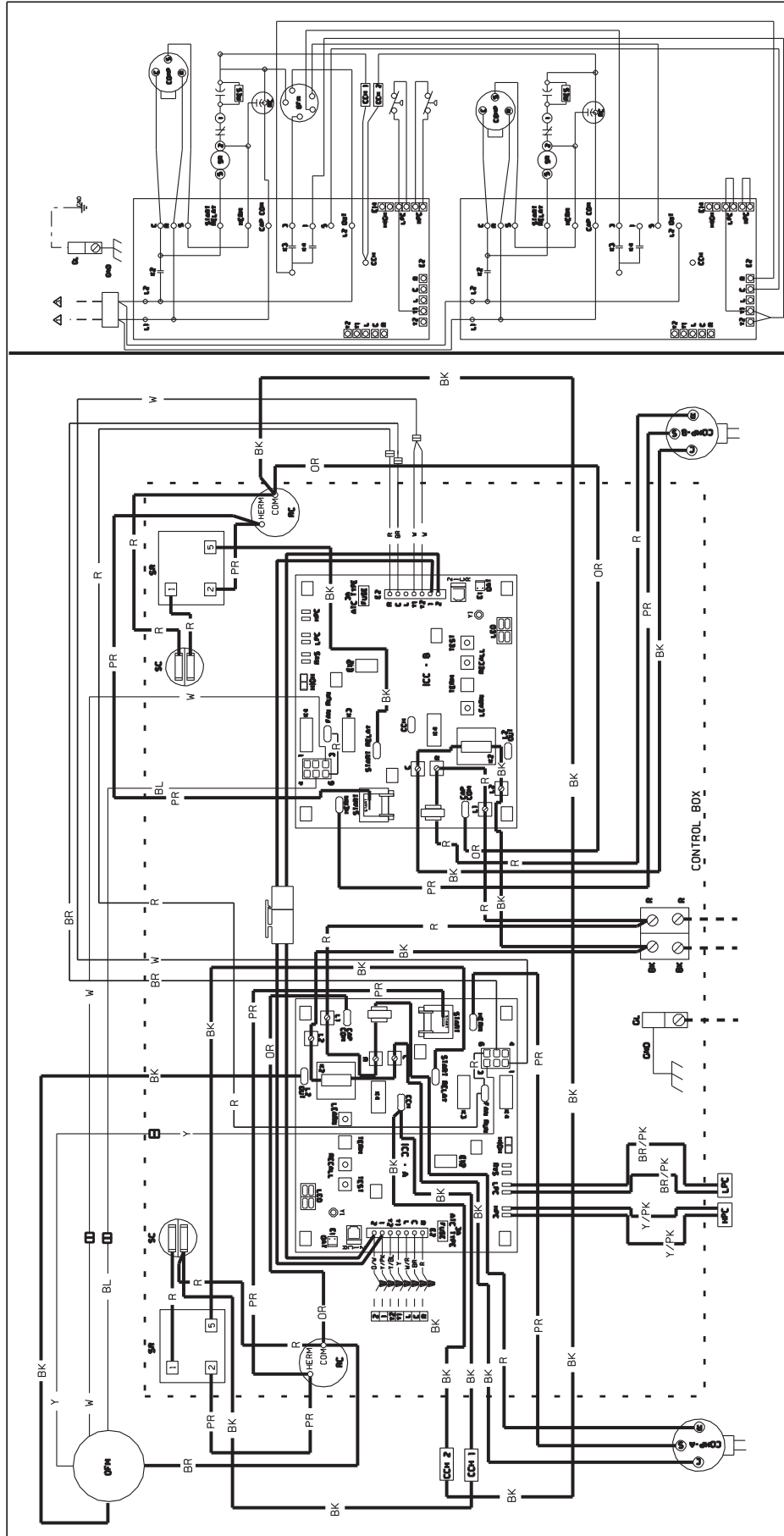

FIGURE 14
WIRING DIAGRAM FOR (-)ASL-039JEC, 048JEC, & 060JEC (DUAL DRIVE)



COMPONENT CODE	
OFM	OUTDOOR FAN MOTOR
GL	GROUND LUG
SC	START CAPACITOR
OPT	OPTIONAL
RC	RUN CAPACITOR
SR	START RELAY
CCH	CRANK CASE HEATER
ICC	INTEGRATED COMPRESSOR CONTROL BOARD RELAY
K	GROUND, CHASSIS
GND	COMPRESSOR
COMP	LOW PRESSURE CONTROL
LPC	HIGH PRES. CUT-OUT CONTROL
HPC	RESISTOR BOARD WIRE TERMINATION
RES	
E	
DWG. NO.	90-102075-06
REV	01

WIRING INFORMATION	
---	LINE VOLTAGE
---	-FACTORY STANDARD
---	-FIELD INSTALLED
---	LOW VOLTAGE
---	-FACTORY STANDARD
---	-FIELD INSTALLED
REPLACEMENT WIRE	
-MUST BE THE SAME SIZE AND TYPE OF INSULATION AS ORIGINAL (105° C MIN.)	
-CABINET MUST BE PERMANENTLY GROUNDED AND CONFORM TO I.E.C., N.E.C., C.E.C. AND LOCAL CODES AS APPLICABLE.	
DWG. NO.	90-102075-06
REV	01

- NOTES:**
- CONNECTORS SUITABLE FOR USE WITH COPPER CONDUCTORS ONLY.
 - COMPRESSOR MOTOR THERMALLY PROTECTED
 - CONNECT FIELD WIRING IN GROUNDED RAINTIGHT CONDUIT TO FUSED DISCONNECT, VOLTAGE, HERTZ AND PHASE PER RATING PLATE.
 - LOW VOLTAGE CIRCUIT TO BE CLASS 2 WITH A CLASS 2 TRANSFORMER 24 VOLT, 50 OR 60 HERTZ, MIN 18 AWG.
 - TO THERMOSTAT, REFER TO SYSTEM SCHEMATICS OR SCHEMATICS ON INDOOR SECTION FOR LOW VOLTAGE CONTROL WIRING.
 - TEST AND ADJUST PRESSURE SWITCHES AND THERMOSTATS WITH L TERMINAL. TORQUE REQUIREMENTS 20 IN.-LB. CHECK ANNUALLY.
 - TEST AND ADJUST PRESSURE SWITCHES AND THERMOSTATS WITH L TERMINAL. TORQUE REQUIREMENTS 20 IN.-LB. CHECK ANNUALLY.
 - 7 - SEGMENT LED TO DISPLAY DIAGNOSTIC CODES.
 - TEST AND ADJUST PRESSURE SWITCHES AND THERMOSTATS WITH L TERMINAL. TORQUE REQUIREMENTS 20 IN.-LB. CHECK ANNUALLY.
 - TEST AND ADJUST PRESSURE SWITCHES AND THERMOSTATS WITH L TERMINAL. TORQUE REQUIREMENTS 20 IN.-LB. CHECK ANNUALLY.
 - TEST AND ADJUST PRESSURE SWITCHES AND THERMOSTATS WITH L TERMINAL. TORQUE REQUIREMENTS 20 IN.-LB. CHECK ANNUALLY.
 - TEST AND ADJUST PRESSURE SWITCHES AND THERMOSTATS WITH L TERMINAL. TORQUE REQUIREMENTS 20 IN.-LB. CHECK ANNUALLY.

WIRE COLOR CODE					
BK	BLACK	GY	GRAY	O	ORANGE
BR	BROWN	Y	YELLOW	PR	PURPLE
BL	BLUE	PK	PINK	R	RED
G	GREEN	W	WHITE		
WIRING DIAGRAM					
DUAL DRIVE CONDENSING UNITS					
208/230 1PH 60HZ.					
DR. BY	JHB	APP. BY	DATE	DWG. NO.	REV
				90-102075-06	01

