

WATER HEATING SOLUTIONS

RESIDENTIAL & COMMERCIAL

RESIDENTIAL

Professional Prestige®, *Classic Plus*® and *Classic*® Tank-Type Models, Tankless Gas and Electric, Marathon®, Solar and more

COMMERCIAL

Tank-Type Gas and Electric, Hot Water Supply Heaters, Tankless Gas and Storage Tanks



WATER | RESIDENTIAL AND COMMERCIAL WATER HEATERS

The new degree of comfort.®

POCKET GUIDE
Effective February 2019

Residential Products

■ ProClub.....	4
■ KwikComfort Financing	5
■ WebSuite™	6
■ Fleet Program	7
■ Vehicle Wrap.....	7
■ Rheem App.....	8-9
■ Professional Model Numbers	10
■ EcoNet®	10
■ ENERGY STAR®	11

■ Gas Tank-Type

Professional Prestige

• Prestige High Efficiency Condensing Power Direct Vent....	12-13
• Prestige Powered Damper.....	14-15
• Prestige Powered Damper Ultra Low NOx	16-17

Professional Classic Plus

• Classic Plus Induced Draft.....	18-19
• Classic Plus Powered Damper	20-21
• Classic Plus Atmospheric.....	22-23
• Classic Plus Heavy Duty	24-25
• Classic Plus Power Direct Vent....	26-29

• Classic Plus Heavy Duty Power Direct Vent.....	30-33
• Classic Plus Heavy Duty Power Vent	34-35
• Classic Plus Powered Damper Ultra Low NOx	36-37
• Classic Plus Ultra Low NOx.....	38-39
• Classic Plus Heavy Duty Ultra Low NOx	40-41

Professional Classic

• Classic Atmospheric.....	42-43
• Classic Power Vent.....	44-45
• Classic Power Direct Vent.....	46-49
• Classic Direct Vent.....	50-51
• Classic Ultra Low NOx.....	53-53
• Classic Power Vent Ultra Low NOx	54-55
• Classic Atmospheric for Mfg. Housing	56-57
• Classic Direct Vent for Mfg. Housing	58-59
• Classic Direct Vent Co-Axial for Mfg. Housing.....	60-61

■ Tankless Gas

Prestige

• Prestige High Efficiency Condensing with Built-in Recirculation.....	62-63
• Prestige High Efficiency Condensing Tankless.....	64-65

Mid-Efficiency

• Mid-Efficiency Tankless	66-67
---------------------------------	-------

■ Combination Boilers.....	68-69
----------------------------	-------

■ Electric Tank-Type

Professional Prestige

• Prestige Hybrid.....	70-71
• Prestige.....	72-73

Professional Classic Plus

• Classic Plus	74-75
----------------------	-------

Professional Classic

• Classic	76-77
• Classic Point-of-Use.....	78-79
• Classic for Mfg. Housing	80-81

Table Top	82-83
-----------------	-------

■ Marathon Electric

• Marathon	84-85
------------------	-------

• Marathon Point-of-Use.....	84-85
------------------------------	-------

■ Water Heater Booster.....	86-87
-----------------------------	-------

■ Tankless Electric

• Classic Tankless Electric.....	88-89
----------------------------------	-------

■ Solar

• SolPak Active System with Electric Backup.....	90-91
• SolPak Active System with Gas Backup	92-93
• Solar Collectors	94-95
• Solaraide HE Tanks.....	96-97
• Solaraide HE with Gas Assist	98-99
• Solaraide Storage Tank.....	100-101
• Marathon Thermal Storage Tank.....	102-103

■ Miscellaneous

• ProtectionPlus	104
• EverKleen System.....	105
• Lifeguard Electric Element.....	106
• Accessories	106

■ Thermal Expansion Tanks.....	107
--------------------------------	-----

Commercial Products

■ Gas Tank-Type

Ultra High Efficiency

- Triton..... 108-109
- Super Duty..... 110-111
- AdvantagePlus..... 112-113

Heavy Duty

- Universal..... 114-115
- Universal Low NOx..... 116-117
- Universal Ultra Low NOx 118-119
- Universal Induced Draft..... 120-121
- Xtreme 122-123
- VentMaster..... 124-125
- Hot Water Supply Heaters..... 126-127

Medium Duty

- Medium Duty 128-129
- Medium Duty Ultra Low NOx.... 130-131
- Power Vent 132-133
- Power Direct Vent..... 134-135
- Power Vent Kits 136-137

- Tankless Gas 138-143

■ Electric Tank-Type

- Large Volume 144-145

Heavy & Medium Duty

- Heavy Duty 146-147
- PowerPack 148-149
- Marathon Heavy Duty..... 150-151
- Marathon Eclipse..... 152-153
- Eclipse 154-155
- Booster 156-157

Light Duty

- Hybrid 158-159
- Light Duty 160-163
- Light Duty w/ Terminal Block... 164-165
- Point-of-Use 166-167

■ Storage Tanks

- Storage Tanks..... 168-169
- Large Volume Storage Tanks.... 170-171

- CertiSpec Web 172

- Conversion Charts..... 173-193



**Time is Money.
We respect your time and
our EliteXpress 48-hour
guarantee proves it.**

Our most popular commercial water heaters will be ready and waiting for the plumbing contractor at any Rheem commercial water heater distributors' warehouse in 48-hours or less.

Models available for 48-hour delivery: Universal, Universal Low NOx, Universal Ultra Low NOx, Xtreme, Medium Duty, Medium Duty Ultra Low NOx, Power Vent, Power Direct Vent, Heavy Duty Electric, PowerPack ASME, Booster, Light Duty Electric, Point-of-Use, Storage Tanks (ST-80, ST-120, ST175)





What is the ProClub Rewards Program?

Welcome to millions of Rewards

ProClub makes it easy for you to earn unlimited rewards for selling dependable Rheem Water Heaters. You'll earn points to use towards gifts for work or play. Plus, your ProClub membership is free, it's simple to redeem points—and it's 100% online.

EASY TO JOIN & SIMPLE TO USE

ProClub is designed to reward you. It's easier than ever to earn, track, and redeem your points—then choose from millions of amazing gifts. It's just our way of saying thanks for your continued support of Rheem Water Heating solutions.

EARN POINTS INSTANTLY

As a ProClub Member, you'll not only earn points for each eligible product you sell, but also for participating in qualified training, and special promotions offered throughout the year. And as long as you're an active member, your points will never expire.*

To learn more about the eligible Rheem solutions that will earn you reward points instantly, visit MyRheem.com/ProClub.

**Points will expire if your account is inactive for 12 months.*

KwikComfort® Financing



The **KwikComfort® Financing** Program provides Residential and Commercial customers with a variety of financing options to get the Rheem water heating system they need on a payment plan that fits their budget. Offering financing can increase a plumbers sales by up to 50% and help customers purchase better grade products for only a few more dollars per month. Offering financing to customers has never been easier.

- ▶ **Residential KwikComfort® Financing** offers homeowners affordable financing options that can be used for Rheem Water Heating equipment, plus installation costs.
- ▶ **Residential KwikComfort® Second Look Financing** offers credit challenged homeowners an alternative financing option when they have been turned down by a primary lender.
- ▶ **Commercial KwikComfort® Financing** allows plumbers to offer financing to commercial owners and national accounts and allows the bundling of the full cost of the job (equipment, ductwork, installation, labor, extended warranty, etc.) into one convenient, affordable monthly payment.

For more information on the KwikComfort financing programs, or to download program literature, visit the **Financing** page under the Marketing tab on [MyRheem.com](https://www.MyRheem.com).



THE RHEEM

WebSuite™



The modern consumer searches online for everything, including plumbers and having a powerful website is key to attracting the right customers to your business. The Rheem WebSuite™ Program offers plumbers modern, professional, and customizable website packages, without all the complications of building it yourself.

- Choose the WebSuite that best fits your business needs
- Simple signup process
- Website is created quick and easy with a professional setup
- We monitor to make sure your site is running correctly

To learn more about the WebSuite Program, log into your **MyRheem** account, navigate to the Marketing Menu and click on **WebSuite**.

Fleet Program

As a Rheem partner with a growing business, you may be ready to add to your fleet of company trucks and vans. Rheem's Fleet program offers major discounts on select 2018 model year vehicles from Dodge, Ram, GM, Ford and Nissan. To see the discounts available to you visit **MyRheem.com** and navigate to the Marketing Menu and click on **Fleet Discount Program**.



Vehicle Wraps

Easily transform your new or current fleet vehicle into a rolling billboard for your business. Rheem has free templates for full vehicle wraps and decals to help identify you as a Rheem partner. Use our predesigned templates or let us create a customized design for you. Best of all, vehicle wraps and decals are co-op eligible. Ask your local distributor if you qualify for discounts with the co-op program.

To see our truck wrap designs and decals, visit **MyRheem.com** and navigate to the Marketing Menu. Under Advertising select **Vehicle Wraps and Decals**.



Rheem App

The Rheem App makes it easy for you to access the tools you use on the job every day – whether you use a smartphone or a tablet. The Rheem App is iOS and Android-friendly – download it now on Apple® iTunes or the Google® Play Store.

TOOLS TO HELP YOU GET THE JOB DONE

- **CUSTOMIZED CONTENT** – based on you, and programs in which you are enrolled
- **QUICK SEARCH** – launch instant product and content searches without navigating through menus
- **SERIAL REGISTRATION** – easily enter serial numbers and homeowner information to register a products warranty and collect ProClub points
- **PARTS LOOKUP** – search by product or serial number to quickly find and order Rheem specific or universal replacement parts

Available for download now



Rheem App

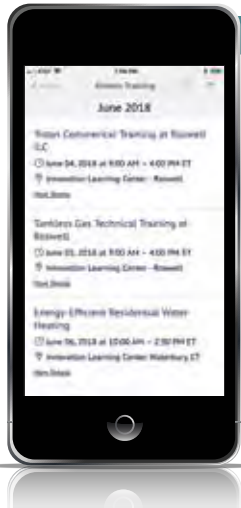

TRAINING

- **TRAINING CALENDAR** –
 - Find the on-site training classes near you
 - Classes include business and technical content
 - Earn ProClub points for all classes



PRODUCT BROWSER & CROSS REFERENCE

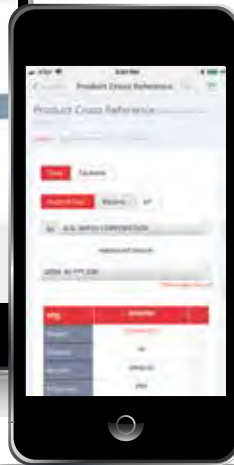

- **PRODUCT BROWSER** – share and send product information, literature, images and more right from the app
- **CROSS REFERENCE** – the cross reference application can help you find Rheem equivalents for many competitor commercial and residential products

Professional Model Numbers

Gas Models

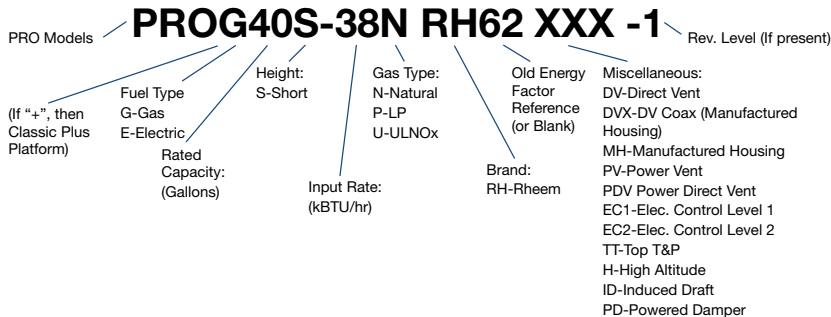

Electric Models

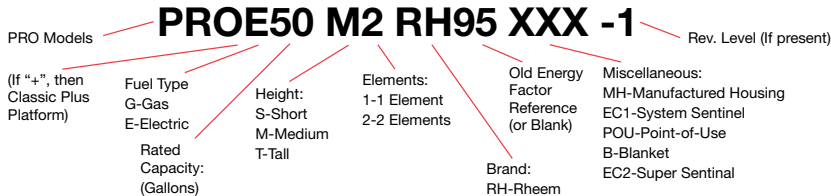

EcoNet®



EcoNet®

Connects high-efficiency Rheem Water Heaters, Furnaces and HVAC units to WiFi for better control and monitoring home system of your home comfort systems.



The EcoNet WiFi Kits* provide remote access to EcoNet Enabled Electric and Gas Water Heaters from mobile apps, mobile friendly web portal, and popular Smart Home applications like NEST & WINK.

Contractor Benefits:

EcoNet makes it easier than ever for homeowners to save energy and achieve that perfect temperature – all while giving you the diagnostics you need to deliver that perfect level of service.

- **Equipment Detection** – EcoNet automatically detects all connected equipment
- **Equipment Alerts** – Help homeowners identify what part of equipment requires attention before making service call
- **Contact Info** – Contractor contact details stored in the EcoNet app are automatically displayed when equipment alerts occur
- **EcoNet** includes vacation mode setting; allows for controlling multiple locations; and provides mobile leak alerts in the event a water leak is detected

*WiFi broadband internet connection required, EcoNet WiFi Kit included on select *Prestige* models.

ENERGY STAR® Qualified Water Heaters



What is ENERGY STAR®?

ENERGY STAR® is a joint program of the U.S.

Environmental Protection Agency and the U.S. Department of Energy helping us all save money and protect the environment through energy efficient products and practices.

Energy efficient choices can save families about a third on their energy bill with similar savings of greenhouse gas emissions, without sacrificing features, style or comfort. ENERGY STAR® helps you make the energy efficient choice.

RESIDENTIAL

Gas Tank Type

Induced Draft

- ★ PRO+G29-60N RH70 ID

Short Powered Damper

- ★ PRO+G40S-40N RH67 PD
- ★ PRO+G50S-40N RH67 PD

Tall Powered Damper

- ★ PROP G38-40N RH69 PD
- ★ PROP G50-40N RH67 PD
- ★ PRO+G38-40N RH69 PD
- ★ PRO+G50-40N RH67 PD
- ★ PRO+G50-50N RH67 PD

Powered Damper

Ultra Low NOx

- ★ PROP G40-38U RH67 PD
- ★ PROP G50-38U RH67 PD
- ★ PRO+G40-38U RH67 PD
- ★ PRO+G50-38U RH67 PD

Short Power Vent

- ★ PROG40S-36N RH67 PV
- ★ PROG50S-36N RH67 PV

Tall Power Vent

- ★ PROG40-40N RH67 PV
- ★ PROG50-42N RH67 PV

Power Vent Ultra Low NOx

- ★ PROG40-36U RH67 PV
- ★ PROG50-38U RH67 PV

Power Direct Vent

- ★ RHE40S
- ★ RHE50
- ★ PROG40-40N RH67 PDV
- ★ PROG50-40N RH67 PDV
- ★ PRO+G50-65N RH62 PDV

Electric Tank Type

Hybrid

- ★ PROPH50 T2 RH350 D
- ★ PROPH65 T2 RH350 D
- ★ PROPH80 T2 RH350 D

Gas Tankless

Direct Vents

- ★ RTGH-RH11DVLN
- ★ RTGH-RH10DVLN
- ★ RTGH-84DVLN-2
- ★ RTGH-90DVLN-2
- ★ RTGH-95DVLN-2
- ★ RTGH-95DVELN-2

Outdoor

- ★ RTGH-84XLN-2
- ★ RTGH-90XLN-2
- ★ RTGH-95XLN-2
- ★ RTGH-95XELN-2

(All Tankless models are available in Natural Gas and Propane (LP). For Propane replace the **N** with **P** when ordering.)

COMMERCIAL

Gas Tank Type

Triton

- ★ GHE80SU/SS-130(A)
- ★ GHE80SU/SS-160(A)
- ★ GHE80SU/SS-200(A)
- ★ GHE80SU/SS-300(A)
- ★ GHE100SU/SS-130(A)
- ★ GHE100SU/SS-160(A)
- ★ GHE100SU/SS-200(A)
- ★ GHE100SU/SS-250(A)
- ★ GHE100SU/SS-300(A)
- ★ GHE100SU/SS-400(A)

AdvantagePlus

- ★ HE55-100
- ★ HE55-130
- ★ HE80-130
- ★ HE119-130
- ★ HE55-160
- ★ HE80-160
- ★ HE119-160
- ★ HE55-199
- ★ HE80-199
- ★ HE119-199

Gas Tankless

Commercial Tankless

- ★ RTGH-C95DVLN
- ★ RTGH-C95XLN

Manifold Ready

Commercial Tankless

- ★ RTGH-CM95DVLN
- ★ RTGH-CM95XLN

(All Tankless models are available in Natural Gas and Propane (LP). For Propane replace the **N** with **P** when ordering.)

Electric Tank Type

Hybrid

- ★ HPLD50
- ★ HPLD65
- ★ HPLD80



Professional Prestige® High Efficiency Condensing Power Direct Vent

Efficiency

- .80 - .83 UEF
- ENERGY STAR® rated

Performance

- FHR: 87 gallons for natural and LP gas
- Recovery: 43.6 to 48.5 GPH at a 90° F rise, depending on model

Self-Diagnostic System

- Integrated system control for easy installation and service
- Diagnostic system control can be replaced without draining the water heater

Low Emissions

- Eco-friendly burner, low NOx design

Features

- Power direct vents are an ideal choice when either indoor air quality or negative air pressure are concerns
- Two-pipe system: one pipe pulls in outside air for combustion and the other exhausts combustion gases
- 120 VAC, 60Hz, induced draft blower
- New whisper quiet blower

Innovative Technology

- Proven center flue design with submerged coil type condensing heat exchanger
- Heat exchanger is porcelain coated inside and out for increased product life

Flammable Vapor Detection System

- FVIR compliant protective
- Control system that disables the heater in the presence of flammable vapor accumulation

Flexible Venting Options

- Long venting lengths up to 60 feet
- Use 2 or 3 inch diameter PVC, ABS, or CPVC vent pipe options. (In Canada ULC S636 PVC and CPVC must be used.)
- Vertical or horizontal termination
- Concentric vent kit available

Longer Life

- Dual anode rods protect the tank from corrosion

High Altitude Compliant

- Models are certified for applications up to 9,000 feet above sea level

Plus...

- Enhanced-flow brass drain valve
- Temperature and pressure relief valve included
- Low lead compliant
- Durable silicon nitride igniter (HSI)
- Inlet tube with diffuser enhances heat transfer
- Front access to condensate trap and vent pipe
- Condensate neutralizer option
- Standard replacement parts

Warranty

- 6-Year limited tank and parts warranty*

*See Residential Warranty Certificate for complete information

Units meet or exceed ANSI requirements and have been tested according to D.O.E. procedures. Units meet or exceed the energy efficiency requirements of NAECA, ASHRAE standard 90, ICC Code and all state energy efficiency performance criteria.



LEED Points = 2

DESCRIPTION				FEATURES						ROUGHING IN DIMENSIONS (SHOWN IN INCHES)										ENERGY INFO.
TYPE	NOMINAL GALLON CAP.	RATED GALLON CAP.	NAT. GAS MODEL NUMBER*	GAS INPUT IN THOUS. BTU/H		RECOVERY IN G.P.H. 90° F RISE		UEF FIRST HR. DEL. G.P.H.		HEIGHT TO TOP OF VENT A	HEIGHT TO TOP OF AIR INLET B	TANK HEIGHT C	DIAM. D	HT. TO GAS CONN. E	WATER CONN. CNTR. F	HT. TO SIDE T&P VALVE G	WATER CONN. SIZE H	FRONT TO BACK I	SHIP WT. (LBS)	UNIFORM ENERGY FACTOR (UEF)
				NAT.	LP	NAT.	LP	NAT.	LP											
Short	38	37	★ RHE40S	40	36	48.5	43.6	87	87	60-3/8	60-1/8	51-1/16	22-1/8	14-1/8	8	44-1/4	3/4	26-11/16	220	0.83
Tall	48	46	★ RHE50	40	36	48.5	43.6	87	87	68-3/4	68-5/8	59-11/16	22-1/8	14-1/8	8	52-7/8	3/4	26-11/16	250	0.80

*Refer to Specification Sheet on Rheem.com for LP model numbers. • Uniform Energy Factor and rated gallon capacity based on Department of Energy (DOE) requirements.

★ ENERGY STAR® compliant model.

Air-Inlet and Venting Information for RHE40S and RHE50

MODEL NUMBER	VENT & COMBUSTION AIR-INLET PIPE DIAMETER (INCHES)	MINIMUM ALLOWED EQUIVALENT VENT & COMBUSTION AIR-INLET LENGTHS – EACH PIPE RUN (FT.)	MAXIMUM ALLOWED EQUIVALENT VENT & COMBUSTION AIR-INLET LENGTHS – EACH PIPE RUN (FT.)	VENT AND COMBUSTION AIR-INLET SYSTEM TERMINATION(S)	
From Sea Level Through 5,999 feet Above Sea Level					
RHE40S	2	7	30	90° Elbows	Concentric*
RHE40S	3	7	60	90° Elbows	Concentric*
RHE50	2	7	30	90° Elbows	Concentric*
RHE50	3	7	60	90° Elbows	Concentric*
From 6,000 feet Above Sea Level Through 8,999 feet Above Sea Level					
RHE40S	2	Not Allowed	Not Allowed	–	–
RHE40S	3	7	45	90° Elbows	Concentric*
RHE50	2	Not Allowed	Not Allowed	–	–
RHE50	3	7	45	90° Elbows	Concentric*

One 90° elbow is equivalent to 5 feet of straight pipe. One 45° elbow is equivalent to 2.5 feet of straight pipe. The vent and combustion air inlet terminations are not included in the equivalency calculations.

* Use only Rheem 3 inch concentric termination kit SP20245.

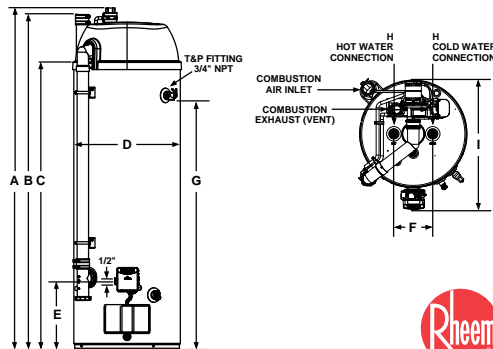

Professional Prestige® Powered Damper

Efficiency

- .68 - .70 UEF
- ENERGY STAR® rated

Performance

- FHR: 78 - 85 gallons
- Recovery: Up to 40.4 GPH at a 90° F rise, depending on model

Self-Diagnostic System

- Electronic gas control for improved monitoring and service

Low Emissions

- Eco-friendly burner, low NOx design
- Meets 40 ng/J NOx requirements

Technology

- 24 VAC flue damper, 110 VAC outlet required
- Includes 19-foot cord, 3-prong plug
- Standard Cat. I, double-wall, B-vent, 3" (4" adaptor included)

Longer Life

- Premium grade anode rod provides long-lasting tank protection



- EcoNet® WiFi-connected† technology and free mobile app gives users control over water systems, allowing for customizable temperature, vacation settings, energy savings and system monitoring at home or away. Visit Rheem.com/EcoNetConnect
- Water sensor detects water outside of the unit and sends an alert via the free EcoNet® mobile app to the homeowner
- EcoNet® WiFi Kit included



Guardian System® & Sensor

- Exclusive air/fuel shut-off device
- Maintenance free – no filter to clean
- Disables the heater in the presence of flammable vapor accumulation

High Altitude Compliant

- Certified for applications up to 10,100 feet above sea level

Plus...

- Dual certified for both potable water and space heating
- Enhanced flow brass drain valve
- Temperature and pressure relief valve included
- Low lead compliant
- EverKleen® patented system fights sediment build-up
- Standard replacement parts

Warranty

- 12-Year limited tank and parts warranty*

*See Residential Warranty Certificate for complete information

† WiFi broadband internet connection required

Units meet or exceed ANSI requirements and have been tested according to D.O.E. procedures. Units meet or exceed the energy efficiency requirements of NAECA, ASHRAE standard 90, ICC Code and all state energy efficiency performance criteria.



LEED Point = 1



DESCRIPTION				FEATURES						ROUGHING IN DIMENSIONS (SHOWN IN INCHES)									ENERGY INFO.
TYPE	NOMINAL GALLON CAPACITY	RATED GALLON CAPACITY	NAT. GAS MODEL NUMBER*	GAS INPUT IN THOUS. BTU/H		RECOVERY IN G.P.H. 90° F RISE		UEF FIRST HR. DEL. G.P.H.		HEIGHT TO VENT A	TANK HEIGHT B	DIAM. C	HT. TO GAS CONN. D	VENT SIZE E	WATER CONN. CENTER F	HT. TO SIDE T&P VALVE G	WATER CONN. SIZE H	SHIP WT. (LBS)	UNIFORM ENERGY FACTOR (UEF)
				NAT.	LP	NAT.	LP	NAT.	LP										
Tall	38	37	★ PROP G38-40N RH69 PD	40	36	40.4	36.4	85	85	62-3/4	57-3/4	19-3/4	14	3 or 4	8	52-1/4	3/4	140	0.70
Tall	50	48	★ PROP G50-40N RH67 PD	40	36	40.4	36.4	78	78	63	58	21-3/4	14	3 or 4	8	52-1/2	3/4	160	0.68

*Refer to Specification Sheet on Rheem.com for LP model numbers.

Uniform Energy Factor and rated gallon capacity based on Department of Energy (DOE) requirements.

★ ENERGY STAR® compliant model.

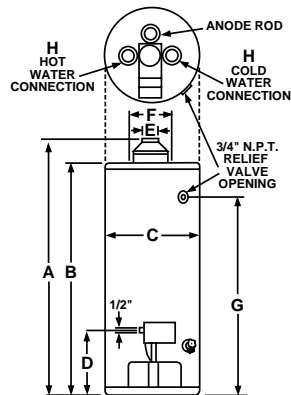

Professional Prestige® Powered Damper Ultra Low NOx

Efficiency

- .64 - .68 UEF
- ENERGY STAR® rated

Performance

- FHR: 86 gallons for 50-gallon model and 67 gallons for 40-gallon
- Recovery: 38 GPH at a 90° F rise

Self-Diagnostic System

- Electronic gas control for improved monitoring and service

Low Emissions

- Ultra Low NOx 38,000 BTU/h burner
- Meets 10 ng/J NOx requirements
- SCAQMD Rule 1121 compliant

Technology

- 24 VAC flue damper, 110 VAC outlet required
- Includes 19-foot cord, 3-prong plug
- Standard Cat. I, double-wall, B-vent, 3" (4" adaptor included)

Longer Life

- Premium grade anode rod provides long-lasting tank protection

Guardian System® & Sensor

- Exclusive fuel shut-off device
- Maintenance free – no filter to clean
- Disables the heater in the presence of flammable vapor accumulation

High Altitude Compliant

- Certified to 5,250 feet above sea level

Plus...

- Dual certified for both potable water and space heating
- Enhanced flow brass drain valve
- Temperature and pressure relief valve included
- Low lead compliant
- EverKleen® patented system fights sediment build-up
- Standard replacement parts

Warranty

- 12-Year limited tank and parts warranty*

*See Residential Warranty Certificate for complete information

Units meet or exceed ANSI requirements and have been tested according to D.O.E. procedures. Units meet or exceed the energy efficiency requirements of NAECA, ASHRAE standard 90, ICC Code and all state energy efficiency performance criteria.



DESCRIPTION				FEATURES			ROUGHING IN DIMENSIONS (SHOWN IN INCHES)									ENERGY INFO.
T Y P E	NOMINAL GALLON CAPACITY	RATED GALLON CAPACITY	MODEL NUMBER	GAS INPUT IN THOUS. BTU/H NAT.	RECOVERY IN G.P.H. 90° F RISE NAT.	UEF FIRST HR. DEL. G.P.H. NAT.	HT. TO VENT A	TANK HEIGHT B	DIAM. C	HT. TO GAS CONN. D	VENT SIZE E	WATER CONN. CENTER F	HT. TO SIDE T&P VALVE G	WATER CONN. SIZE H	SHIP WT. (LBS)	UNIFORM ENERGY FACTOR (UEF)
Tall	40	38	★ PROP G40-38U RH67 PD	38	38	67	65	60-1/4	19-3/4	13	3 or 4	8	53-1/2	3/4	140	0.64
Tall	50	48	★ PROP G50-38U RH67 PD	38	38	86	64	59-1/4	21-3/4	13	3 or 4	8	52-1/2	3/4	150	0.68

Uniform Energy Factor and rated gallon capacity based on Department of Energy (DOE) requirements.

★ **ENERGY STAR®** compliant model.

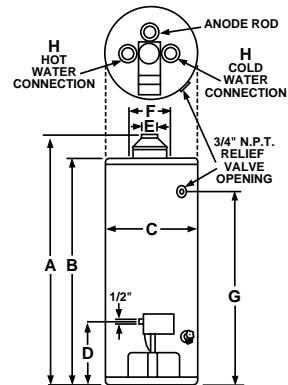

Professional Classic Plus® Induced Draft

Efficiency

- .71 UEF
- ENERGY STAR® rated
- Well insulated for reduced stand-by heat loss

Performance

- 29-Gallon capacity with 93 gallon FHR performance
- Recovery: 61 GPH at 90° F rise

Compact Size

- Small foot print, 17-3/4 inch diameter
- Fast one-man installation, compact and light weight

Self-Diagnostic System

- Integrated self-diagnostic system control for easy installation and service

Low Emissions

- Eco-friendly burner, low NOx design
- Meets 40 ng/J NOx requirements

Technology

- 110 VAC draft inducer (includes 8-foot cord with 3-prong plug)
- Standard atmospheric Category I, double-wall, B-vent, 3" or 4" (4" adaptor included)
- Fan assisted draft inducer creates the proper draft to expel the combustion gases

Guardian System® & Sensor

- Exclusive air/fuel shut-off device for double protection
- Maintenance free – no filter to clean
- Disables the heater in the presence of flammable vapor accumulation

Longer Life

- Premium grade anode rod provides long-lasting tank protection

High Altitude Compliant

- Certified for applications up to 10,100 feet above sea level

Plus...

- Dual certified for both potable water and space heating
- Enhanced-flow brass drain valve
- Temperature and pressure relief valve included
- Low lead compliant
- EverKleen® patented system fights sediment build-up
- Standard replacement parts

Warranty

- 8-Year limited tank and parts warranty*
- With ProtectionPlus® the 8-year limited tank warranty becomes 12-year

*See Residential Warranty Certificate for complete information

Units meet or exceed ANSI requirements and have been tested according to D.O.E. procedures. Units meet or exceed the energy efficiency requirements of NAECA, ASHRAE standard 90, ICC Code and all state energy efficiency performance criteria.



ANSI CERTIFIED



LEED Point = 1



DESCRIPTION			FEATURES			ROUGHING IN DIMENSIONS (SHOWN IN INCHES)									ENERGY INFO.
NOMINAL GALLON CAPACITY	RATED GALLON CAPACITY	MODEL NUMBER	GAS INPUT IN THOUS. BTU/H NAT.	RECOVERY IN G.P.H. 90° F RISE NAT.	UEF FIRST HR. DELIVERY G.P.H.	HT. TO VENT A	TANK HEIGHT B	DIAM. C	HT. TO GAS CONN. D	VENT SIZE E	WATER CONN. CENTER F	HT. TO SIDE T&P VALVE G	WATER CONN. SIZE H	SHIP WT. (LBS)	UNIFORM ENERGY FACTOR (UEF)
29	28	★ PRO+G29-60N RH70 ID	60	61	93	65-1/2	58-1/4	17-3/4	14	3 or 4	8	51-9/16	3/4	136	0.71

Uniform Energy Factor and rated gallon capacity based on Department of Energy (DOE) requirements.

★ **ENERGY STAR® compliant model.**

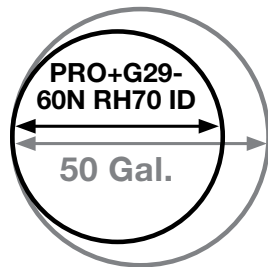

Footprint Comparison

Narrow 17-3/4 inch diameter fits in a smaller space than standard 40 or 50-gallon models.

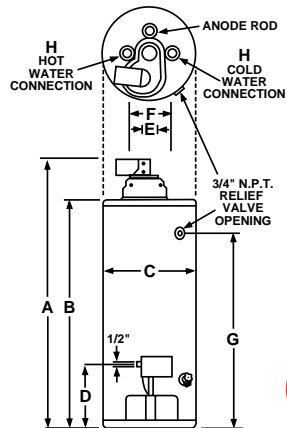

Professional Classic Plus® Powered Damper

Efficiency

- .65 - .70 UEF
- ENERGY STAR® rated

Performance

- FHR: 69 - 85 gallons
- Recovery: Up to 50.5 GPH at a 90° F rise, depending on model

Self-Diagnostic System

- Electronic gas control for improved monitoring and service

Low Emissions

- Eco-friendly burner, low NOx design
- Meets 40 ng/J NOx requirements

Technology

- 24 VAC flue damper, 110 VAC outlet required
- Includes 19-foot cord, 3-prong plug
- Standard Cat. I, double-wall, B-vent, 3" (4" adaptor included)

Longer Life

- Premium grade anode rod provides long-lasting tank protection



- EcoNet® enabled WiFi-connected[†] technology and free mobile app gives users control over water systems, allowing for customizable temperature, vacation settings, energy savings and system monitoring at home or away. Visit Rheem.com/EcoNetConnect
- Water sensor detects water outside of the unit and sends an alert via the free EcoNet® mobile app to the homeowner
- EcoNet® WiFi Kit part number EEWRA631GWH sold separately



Guardian System® & Sensor

- Exclusive air/fuel shut-off device
- Maintenance free – no filter to clean
- Disables the heater in the presence of flammable vapor accumulation

High Altitude Compliant

- Certified to 10,100 feet above sea level (50-gallon 50K BTU/h model certified to 5,999 feet above sea level)

Plus...

- Dual certified for both potable water and space heating
- Enhanced-flow brass drain valve
- Temperature and pressure relief valve included
- Low lead compliant
- Standard replacement parts

Warranty

- 8-Year limited tank and parts warranty*
- With ProtectionPlus® the 8-year limited tank warranty becomes 12-year

*See Residential Warranty Certificate for complete information

[†]WiFi broadband internet connection required, WiFi Kit sold separately

Units meet or exceed ANSI requirements and have been tested according to D.O.E. procedures. Units meet or exceed the energy efficiency requirements of NAECA, ASHRAE standard 90, ICC Code and all state energy efficiency performance criteria.



LEED Point = 1



DESCRIPTION				FEATURES						ROUGHING IN DIMENSIONS (SHOWN IN INCHES)									ENERGY INFO.
TYPE	NOMINAL GALLON CAPACITY	RATED GALLON CAPACITY	NAT. GAS MODEL NUMBER*	GAS INPUT IN THOUS. BTU/H		RECOVERY IN G.P.H. 90° F RISE		UEF FIRST HR. DEL. G.P.H.		HEIGHT TO VENT A	TANK HEIGHT B	DIAM. C	HT. TO GAS CONN. D	VENT SIZE E	WATER CONN. CENTER F	HT. TO SIDE T&P VALVE G	WATER CONN. SIZE H	SHIP WT. (LBS)	UNIFORM ENERGY FACTOR (UEF)
				NAT.	LP	NAT.	LP	NAT.	LP										
Tall	38	37	★ PRO+G38-40N RH69 PD	40	36	40.4	36.4	85	85	62-3/4	57-3/4	19-3/4	14	3 or 4	8	52-1/4	3/4	140	0.70
Tall	50	48	★ PRO+G50-40N RH67 PD	40	36	40.4	36.4	78	78	63	58	21-3/4	14	3 or 4	8	52-1/2	3/4	160	0.68
Tall	50	48	★ PRO+G50-50N RH67 PD	50	-	50.5	-	84	-	63-1/2	58	21-3/4	14	4	8	52-1/2	3/4	160	0.69
Short	40	39	★ PRO+G40S-40N RH67 PD	40	36	40.4	36.4	69	69	55-1/2	50-1/2	21-3/4	14	3 or 4	8	44	3/4	140	0.65
Short	50	48	★ PRO+G50S-40N RH67 PD	40	36	40.4	36.4	78	78	55-1/2	50-1/2	23-3/4	14	3 or 4	8	44	3/4	160	0.66

*Refer to Specification Sheet on Rheem.com for LP model numbers.

Uniform Energy Factor and rated gallon capacity based on Department of Energy (DOE) requirements.

★ ENERGY STAR® compliant model.

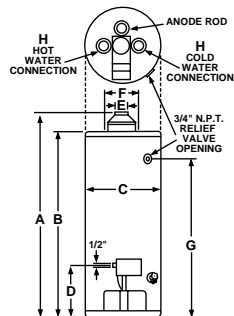

Professional Classic Plus® Atmospheric

Efficiency

- .58 - 66 UEF
- More hot water at a low operating cost

Performance

- FHR: 52 to 105 gallons for natural gas
- Recovery: 36.4 to 61 GPH at a 90° F rise, depending on model

Guardian System® & Sensor

- Exclusive air/fuel shut-off device
- Maintenance free – no filter to clean
- Disables the heater in the presence of flammable vapor accumulation

Low Emissions

- Eco-friendly burner, low NOx design
- Meets 40 ng/J NOx requirements

Longer Life

- Premium grade anode rod provides long-lasting tank protection

Plus...

- Easy to light – no matches required
- EverKleen® patented system fights sediment build-up
- Side water connections for space heating applications on the 48-gallon tall model
- Enhanced flow brass drain valve
- Temperature and pressure relief valve included
- Low lead compliant
- Standard replacement parts

Warranty

- 8-Year limited tank and parts warranty*
- With ProtectionPlus® the 8-year limited tank warranty becomes 12-year

*See Residential Warranty Certificate for complete information

Units meet or exceed ANSI requirements and have been tested according to D.O.E. procedures. Units meet or exceed the energy efficiency requirements of NAECA, ASHRAE standard 90, ICC Code and all state energy efficiency performance criteria.



ANSI CERTIFIED



LEED Point = 1



DESCRIPTION				FEATURES						ROUGHING IN DIMENSIONS (SHOWN IN INCHES)										ENERGY INFO.
TYPE	NOMINAL GALLON CAPACITY	RATED GALLON CAPACITY	NAT. GAS MODEL NUMBER*	GAS INPUT IN THOUS. BTU/H		RECOVERY IN G.P.H. 90° F RISE		UEF FIRST HR. DEL. G.P.H.		HEIGHT TO VENT A	TANK HEIGHT B	DIAM. C	HT. TO GAS CONN. D	VENT SIZE E	WATER CONN. CENTER F	HT. TO SIDE T&P VALVE G	WATER CONN. SIZE H	SHIP WT. (LBS)	UNIFORM ENERGY FACTOR (UEF)	
				NAT.	LP	NAT.	LP	NAT.	LP											
Tall	40	38	PRO+G40-40N RH62†	40	36	40.4	36.4	84	84	63-1/4	60	19-1/2	14	3 or 4	8	53-1/2	3/4	135	0.66	
Tall	48	46	PRO+G48-60N RH60	60	54	61	55	105	105	61-3/4	58-1/2	21-3/4	14-3/8	4	11	51-7/8	3/4	150	0.62	
Tall	50	48	PRO+G50-40N RH62†	40	36	40.4	36.4	76	76	62-1/2	59-1/4	21-1/2	14	3 or 4	8	52-1/2	3/4	165	0.65	
Tall	55	55	PRO+G55-50N RH59	50	45	51	46	91	91	59-1/8	55-7/8	23-3/4	14-1/4	4	8	48-3/4	3/4	175	0.62	
Short	40	38	PRO+G40S-40N RH62†	40	36	40.4	36.4	52	52	54	50-1/2	23	14	3 or 4	8	44	3/4	135	0.58	
Short	50	48	PRO+G50S-40N RH61	40	36	40.4	36.4	87	87	54-1/4	51-1/8	23-3/4	14-1/4	3 or 4	8	44	3/4	186	0.63	

*Refer to Specification Sheet on Rheem.com for LP model numbers.

Uniform Energy Factor and rated gallon capacity based on Department of Energy (DOE) requirements.



LEED Point = 1

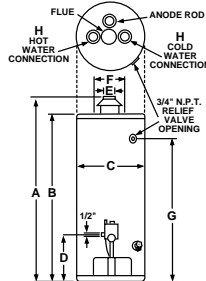
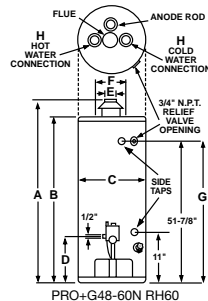

Professional Classic Plus® Heavy Duty

Performance

- Recovery Capacity: 72.8 gallons per hour (delivers approximately 100 gallons of hot water in the first hour for 75-gallon models and 142 gallons for 98-gallon models)**

Guardian System® & Sensor

- Exclusive air/fuel shut-off device
- Maintenance free – no filter to clean
- Disables the heater in the presence of flammable vapor accumulation

Easy to Light

- Piezo Ignitor - no matches required

Low Emissions

- Eco-friendly burner, low NOx design
- Meets 40 ng/J NOx requirements

Longer Life

- Premium grade anode rod provides long-lasting tank protection

High Altitude Compliant

- All models are certified for applications up to 8,500 feet above sea level

Plus...

- Enhanced-flow brass drain valve
- Temperature and pressure relief valve included
- Low lead compliant
- Side water connections for space heating applications
- Standard replacement parts

Warranty

- 8-Year limited tank and parts warranty*
- With ProtectionPlus® the 8-year limited tank warranty becomes 12-year

*See Warranty Certificate for complete information

Efficiency | All models tested according to ANSI test procedures, and meet or exceed the thermal efficiency and standby loss requirements of current ASHRAE standard (EPact). Also exceeds energy efficiency codes of all states including California Energy Commission (CEC).

Safety and Construction | Design certified by CSA: For operation at 160 degrees; meets all safety and construction requirements of ANSI Z21.10.3; as an automatic storage or instantaneous water heater; as an automatic circulating tank water heater; and for operation on combustible floors and in alcove installations. All models are North Carolina Code compliant. **Certified for 150 PSI maximum working pressure.**



DESCRIPTION				FEATURES				ROUGHING IN DIMENSIONS (SHOWN IN INCHES)										ENERGY INFO.
TYPE	NOMINAL GALLON CAPACITY	RATED GALLON CAPACITY	NAT. GAS MODEL NUMBER*	GAS INPUT IN THOUS. BTU/H		RECOVERY IN G.P.H. 100° F RISE**		UEF FIRST HR. DELIVERY G.P.H.	HEIGHT TO VENT A	TANK HEIGHT B	DIAM. C	HT. TO GAS CONN. D	VENT SIZE E	WATER CONN. CENTER F	HT. TO SIDE T&P VALVE G	WATER CONN. SIZE H	SHIP WEIGHT (LBS)	UNIFORM ENERGY FACTOR (UEF)
				NAT.	LP	NAT.	LP											
Tall	75	73	PRO+G75-76N RH	75.1	75.1	72.8	72.8	100	64	60	26-1/4	14-3/4	4	11	53-1/4	1	320	0.61
Tall	98	93	PRO+G98-76N RH	75.1	75.1	72.8	72.8	142	67-7/8	64	28-1/4	14-7/8	4	11	57-3/16	1	350	0.58

*Refer to Specification Sheet on Rheem.com for LP model numbers.

**Recovery Capacity is based upon a 100° F water temperature rise and calculated per ANSI Z21.10.3 standards.

Uniform Energy Factor and rated gallon capacity based on Department of Energy (DOE) requirements.

• 160° F Max. temperature setting.

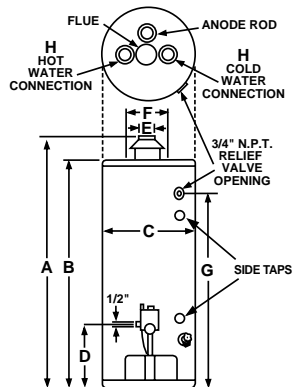

Professional Classic Plus® Power Direct Vent

Efficiency

- .65 UEF
- ENERGY STAR® rated

Performance

- FHR: 111 gallons for natural and 81 gallons for LP gas
- Recovery: 47.5 to 65.7 GPH at a 90° F rise, depending on model

Self-Diagnostic System

- Electronic gas control for improved monitoring and service

Low Emissions

- Eco-friendly burner, low NOx design

Features

- Two pipe system: one pipe pulls in outside air for combustion and the other exhausts combustion gases
- 120 VAC powered blower
- New whisper quiet blower

Flammable Vapor Detection System

- Protective control system that disables the heater in the presence of flammable vapor accumulation

Flexible Venting Options

- Long venting lengths up to 100 feet
- PVC, ABS, or CPVC vent and air inlet options
- Vertical or horizontal vent and air inlet system configurations
- 3" and 4" Concentric vent kits available

Longer Life

- Premium grade anode rod provides long-lasting tank protection

High Altitude Compliant

- Models are certified for applications up to 10,100 feet above sea level

Plus...

- Enhanced-flow brass drain valve
- Temperature and pressure relief valve included
- Low lead compliant
- Durable silicon nitride igniter (HSI)
- Side taps for space heating applications
- EverKleen® patented system fights sediment build-up
- Standard replacement parts

Warranty

- 8-Year limited tank and parts warranty*
- With ProtectionPlus® the 8-year limited tank warranty becomes 12-year

*See Residential Warranty Certificate for complete information

Units meet or exceed ANSI requirements and have been tested according to D.O.E. procedures. Units meet or exceed the energy efficiency requirements of NAECA, ASHRAE standard 90, ICC Code and all state energy efficiency performance criteria.



ANSI CERTIFIED



LEED Point = 1



DESCRIPTION				FEATURES						ROUGHING IN DIMENSIONS (SHOWN IN INCHES)										ENERGY INFO.
TYPE	NOMINAL GALLON CAP.	RATED GALLON CAP.	NAT. GAS MODEL NUMBER*	GAS INPUT IN THOUS. BTU/H		RECOVERY IN G.P.H. 90° F RISE		UEF FIRST HR. DEL. G.P.H.		HEIGHT TO TOP OF VENT A	HEIGHT TO TOP OF AIR INLET B	TANK HEIGHT C	DIAM. D	HT. TO GAS CONN. E	WATER CONN. CNTR. F	HT. TO SIDE T&P VALVE G	WATER CONN. SIZE H	FRONT TO BACK I	SHIP WT. (LBS)	UNIFORM ENERGY FACTOR (UEF)
				NAT.	LP	NAT.	LP	NAT.	LP											
Tall	50	48	★ PRO+G50-65N RH62 PDV	65	47	65.7	47.5	111	81	67-5/8	68-3/8	59-3/8	21-3/4	14	8	52-3/4	3/4	31-1/2	210	0.65

*Refer to Specification Sheet on Rheem.com for LP model numbers.

Uniform Energy Factor and rated gallon capacity based on Department of Energy (DOE) requirements.

★ ENERGY STAR® compliant model.

Air-Inlet and Venting Information – See Next Page.

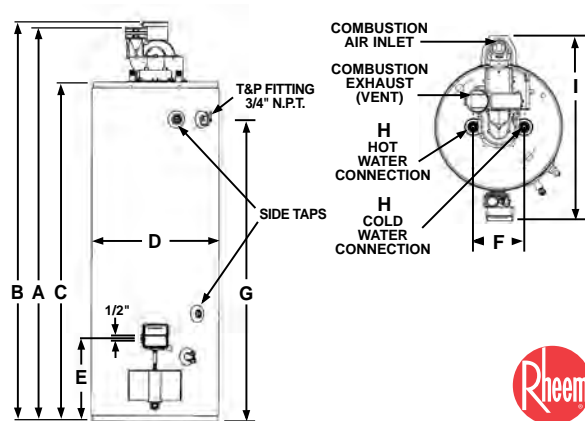

Professional Classic Plus® Power Direct Vent

Vent and Combustion Air Inlet System

MODEL NUMBER	VENT & COMBUSTION AIR-INLET SYSTEM DIAMETER	MIN. ALLOWED EQUIVALENT VENT & COMBUSTION AIR-INLET SYSTEM LENGTHS (EACH PIPE RUN)		MAX. ALLOWED EQUIVALENT VENT & COMBUSTION AIR-INLET SYSTEM LENGTHS (EACH PIPE RUN)		VENT AND COMBUSTION AIR-INLET SYSTEM TERMINATION(S)	
	INCHES	FEET	METERS	FEET	METERS		
FROM SEA LEVEL TO 2,000 FT. (609 M) ABOVE SEA LEVEL							
PRO+G50-65N RH62 PDV AND PRO+G50-47P RH62 PDV	3	7	2.1	50	15.2	90° Elbows	–
	3	7	2.1	40	12.2	–	Concentric*
	3	7	2.1	40	12.2	–	Concentric**
	4	7	2.1	100	30.5	90° Elbows	–
	4	7	2.1	90	27.4	–	Concentric*
	4	7	2.1	90	27.4	–	Concentric**
FROM 2,000 FT. (609 M) THROUGH 5,400 FT. (1,646 M) ABOVE SEA LEVEL							
PRO+G50-65N RH62 PDV AND PRO+G50-47P RH62 PDV	3	7	2.1	50	15.2	90° Elbows	–
	3	7	2.1	40	12.2	–	Concentric*
	3	7	2.1	40	12.2	–	Concentric**
	4	7	2.1	100	30.5	90° Elbows	–
	4	7	2.1	90	27.4	–	Concentric*
	4	7	2.1	90	27.4	–	Concentric**

One 90° elbow is approximately equivalent to 5 feet of pipe. One 45° elbow is approximately equivalent to 2.5 feet of pipe.

*Use only Rheem 3 in. (7.6 cm) concentric termination kit number SP20245.

**Use only Rheem 4 in. (10.2 cm) concentric termination kit number SP20919.

Vent and Combustion Air Inlet System

MODEL NUMBER	VENT & COMBUSTION AIR-INLET SYSTEM DIAMETER	MIN. ALLOWED EQUIVALENT VENT & COMBUSTION AIR-INLET SYSTEM LENGTHS (EACH PIPE RUN)		MAX. ALLOWED EQUIVALENT VENT & COMBUSTION AIR-INLET SYSTEM LENGTHS (EACH PIPE RUN)		VENT AND COMBUSTION AIR-INLET SYSTEM TERMINATION(S)	
	INCHES	FEET	METERS	FEET	METERS		
FROM 6,000 FT. (1,829 M) ABOVE SEA LEVEL THROUGH 7,800 FT. (2,377 M) ABOVE SEA LEVEL							
PRO+G50-65N RH62 PDV AND PRO+G50-47P RH62 PDV	3	7	2.1	50	15.2	90° Elbows	–
	3	7	2.1	40	12.2	–	Concentric*
	3	7	2.1	40	12.2	–	Concentric**
	4	7	2.1	100	30.5	90° Elbows	–
	4	7	2.1	90	27.4	–	Concentric*
	4	7	2.1	90	27.4	–	Concentric**
FROM 7,701 FT. (2,347 M) ABOVE SEA LEVEL THROUGH 10,100 FT. (3,078 M) ABOVE SEA LEVEL							
PRO+G50-65N RH62 PDV AND PRO+G50-47P RH62 PDV	3	7	2.1	25	7.6	90° Elbows	–
	3	7	2.1	20	6.1	–	Concentric*
	3	7	2.1	20	6.1	–	Concentric**
	4	7	2.1	50	15.2	90° Elbows	–
	4	7	2.1	45	13.7	–	Concentric*
	4	7	2.1	45	13.7	–	Concentric**

One 90° elbow is approximately equivalent to 5 feet of pipe. One 45° elbow is approximately equivalent to 2.5 feet of pipe.

*Use only Rheem 3 in. (7.6 cm) concentric termination kit number SP20245.

**Use only Rheem 4 in. (10.2 cm) concentric termination kit number SP20919.



Professional Classic Plus® Heavy Duty Power Direct Vent

Efficiency

- .63 UEF

Performance

- Recovery Capacity: 72.8 gallons per hour (delivers approximately 120 gallons of hot water in the first hour)**

Self-Diagnostic System

- Electronic gas control for improved monitoring and service

Low Emissions

- Eco-friendly burner, low NOx design

Features

- Two pipe system: one pipe pulls in outside air for combustion and the other exhausts combustion gases
- 120 VAC powered blower
- New whisper quiet blower

Flammable Vapor Detection System

- Protective control system that disables the heater in the presence of flammable vapor accumulation

High Altitude Compliant

- Models are certified for applications up to 10,100 feet above sea level

Flexible Venting Options

- Long venting lengths up to 100 feet
- PVC, ABS, or CPVC vent and air inlet options
- Vertical or horizontal vent and air inlet system configurations
- 3" and 4" Concentric vent kits available

Longer Life

- Premium grade anode rod provides long-lasting tank protection

Plus...

- Enhanced-flow brass drain valve
- Temperature and pressure relief valve included
- Low lead compliant
- Durable silicon nitride igniter (HSI)
- Side taps for space heating applications
- EverKleen® patented system fights sediment build-up
- Standard replacement parts

Warranty

- 8-Year limited tank and parts warranty*
- With ProtectionPlus® the 8-year limited tank warranty becomes 12-year

*See Warranty Certificate for complete information



ANSI CERTIFIED

Safety and Construction | Design certified by CSA: For operation at 160 degrees; meets all safety and construction requirements of ANSI Z21.10.3; as an automatic storage water heater; and for operation on combustible floors and in alcove installations. All models are North Carolina Code compliant. **Certified for 150 PSI maximum working pressure.**

2000
PROCLUB
POINTS



DESCRIPTION				FEATURES				ROUGHING IN DIMENSIONS (SHOWN IN INCHES)										ENERGY INFO.	
TYPE	NOMINAL GALLON CAP.	RATED GALLON CAP.	NAT. GAS MODEL NUMBER*	GAS INPUT IN THOUS. BTU/H		RECOVERY IN G.P.H. 100° F RISE**		UEF FIRST HR. DELIVERY G.P.H.	HEIGHT TO TOP OF VENT A	HEIGHT TO TOP OF AIR INLET B	TANK HEIGHT C	DIAM. D	HT. TO GAS CONN. E	WATER CONN. CNTR. F	HT. TO SIDE T&P VALVE G	WATER CONN. SIZE H	FRONT TO BACK I	SHIP WT. (LBS)	UNIFORM ENERGY FACTOR (UEF)
				NAT.	LP	NAT.	LP												
Tall	75	73	PRO+G75-75N RH PDV	75.1	75.1	72.8	72.8	120	70-3/8	71-1/4	60-1/2	26-1/4	15	11	53	1	36-3/4	325	0.63

*Refer to Specification Sheet on Rheem.com for LP model numbers.

**Recovery Capacity is based upon a 100° F water temperature rise and calculated per ANSI Z21.10.3 standards. Uniform Energy Factor and rated gallon capacity based on Department of Energy (DOE) requirements.

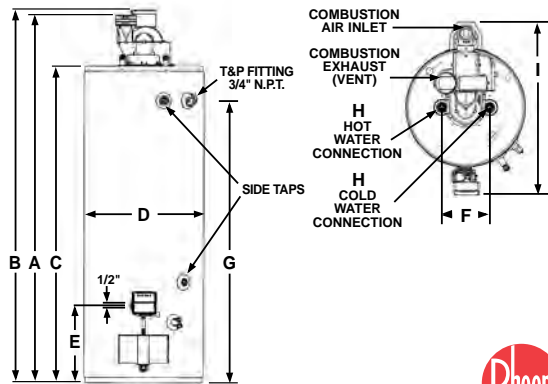

Professional Classic Plus® Heavy Duty Power Direct Vent

Vent and Combustion Air Inlet System

MODEL NUMBER	VENT & COMBUSTION AIR-INLET SYSTEM DIAMETER	MIN. ALLOWED EQUIVALENT VENT & COMBUSTION AIR-INLET SYSTEM LENGTHS (EACH PIPE RUN)		MAX. ALLOWED EQUIVALENT VENT & COMBUSTION AIR-INLET SYSTEM LENGTHS (EACH PIPE RUN)		VENT AND COMBUSTION AIR-INLET SYSTEM TERMINATION(S)	
	INCHES	FEET	METERS	FEET	METERS		
FROM SEA LEVEL TO 2,000 FT. (609 M) ABOVE SEA LEVEL							
PRO+G75-75N RH PDV AND PRO+G75-76P RH PDV	3	8	2.4	50	15.2	90° Elbows	–
	3	8	2.4	40	12.2	–	Concentric*
	3	8	2.4	40	12.2	–	Concentric**
	4	8	2.4	100	30.5	90° Elbows	–
	4	8	2.4	90	27.4	–	Concentric*
	4	8	2.4	90	27.4	–	Concentric**
FROM 2,000 FT. (609 M) THROUGH 5,400 FT. (1,646 M) ABOVE SEA LEVEL							
PRO+G75-75N RH PDV AND PRO+G75-76P RH PDV	3	8	2.4	25	7.6	90° Elbows	–
	3	8	2.4	20	6.1	–	Concentric*
	3	8	2.4	20	6.1	–	Concentric**
	4	8	2.4	100	30.5	90° Elbows	–
	4	8	2.4	90	27.4	–	Concentric*
	4	8	2.4	20	6.1	–	Concentric**

One 90° elbow is approximately equivalent to 5 feet of pipe. One 45° elbow is approximately equivalent to 2.5 feet of pipe.

*Use only Rheem 3 in. (7.6 cm) concentric termination kit number SP20245.

**Use only Rheem 4 in. (10.2 cm) concentric termination kit number SP20919.

Vent and Combustion Air Inlet System

MODEL NUMBER	VENT & COMBUSTION AIR-INLET SYSTEM DIAMETER	MIN. ALLOWED EQUIVALENT VENT & COMBUSTION AIR-INLET SYSTEM LENGTHS (EACH PIPE RUN)		MAX. ALLOWED EQUIVALENT VENT & COMBUSTION AIR-INLET SYSTEM LENGTHS (EACH PIPE RUN)		VENT AND COMBUSTION AIR-INLET SYSTEM TERMINATION(S)	
	INCHES	FEET	METERS	FEET	METERS		
FROM 6,000 FT. (1,829 M) ABOVE SEA LEVEL THROUGH 7,800 FT. (2,377 M) ABOVE SEA LEVEL							
PRO+G75-75N RH PDV AND PRO+G75-76P RH PDV	4	8	2.4	50	15.2	90° Elbows	–
PRO+G75-75N RH PDV	4	8	2.4	45	13.7	–	Concentric*
	4	8	2.4	45	13.7	–	Concentric**
FROM 7,701 FT. (2,347 M) ABOVE SEA LEVEL THROUGH 10,100 FT. (3,078 M) ABOVE SEA LEVEL							
PRO+G75-75N RH PDV	4	8	2.4	50	15.2	90° Elbows	–
	4	8	2.4	45	13.7	–	Concentric*
	4	8	2.4	45	13.7	–	Concentric**

One 90° elbow is approximately equivalent to 5 feet of pipe. One 45° elbow is approximately equivalent to 2.5 feet of pipe.

*Use only Rheem 3 in. (7.6 cm) concentric termination kit number SP20245.

**Use only Rheem 4 in. (10.2 cm) concentric termination kit number SP20919.



Professional Classic Plus® Heavy Duty Power Vent

Performance

- Recovery Capacity: 72.8 gallons per hour (delivers approximately 110 gallons of hot water in the first hour)**

Self-Diagnostic System

- Electronic gas control for improved monitoring and service

Low Emissions

- Eco-friendly burner, low NOx design

Features

- Uses indoor air for combustion; blower exhausts the flue gases
- Standard 110 VAC electrical connection
- New whisper quiet blower
- Offers larger capacities than the standard Power Vent

Guardian System® & Sensor

- Exclusive air/fuel shut-off device
- Maintenance free – no filter to clean
- Disables the heater in the presence of flammable vapor accumulation

Flexible Venting Options

- Long venting lengths up to 100 equivalent feet
- PVC, ABS, or CPVC vent pipe options
- Vertical or horizontal termination

Longer Life

- Premium grade anode rod provides long-lasting tank protection

High Altitude Compliant

- All models are certified for applications up to 8,500 feet above sea level

Plus...

- Enhanced-flow brass drain valve
- Temperature and pressure relief valve included
- Low lead compliant
- Durable silicon nitride ignitor (HSI)
- EverKleen® patented system fights sediment build-up
- Standard replacement parts

Warranty

- 8-Year limited tank and parts warranty*
- With ProtectionPlus® the 8-year limited tank warranty becomes 12-year

*See Warranty Certificate for complete information

Efficiency | All models tested according to ANSI test procedures, and meet or exceed the thermal efficiency and standby loss requirements of current ASHRAE standard (EPact). Also exceeds energy efficiency codes of all states including California Energy Commission (CEC).

Safety and Construction | Design certified by CSA: For operation at 160 degrees; meets all safety and construction requirements of ANSI Z21.10.3; as an automatic storage or instantaneous water heater; as an automatic circulating tank water heater; and for operation on combustible floors and in alcove installations. All models are North Carolina Code compliant. **Certified for 150 PSI maximum working pressure.**



2000
PROCLUB
POINTS



DESCRIPTION				FEATURES				ROUGHING IN DIMENSIONS (SHOWN IN INCHES)								ENERGY INFO.	
TYPE	NOMINAL GALLON CAPACITY	RATED GALLON CAPACITY	NAT. GAS MODEL NUMBER*	GAS INPUT IN THOUS. BTU/H		RECOVERY IN G.P.H. 100° F RISE**		UEF FIRST HR. DELIVERY G.P.H.	HEIGHT TO TOP OF ASSEMBLY A	TANK HEIGHT B	DIAM. C	HT. TO GAS CONN. D	WATER CONN. CENTER E	HT. TO SIDE T&P VALVE F	WATER CONN. SIZE G	SHIP WEIGHT (LBS)	UNIFORM ENERGY FACTOR (UEF)
				NAT.	LP	NAT.	LP										
Tall	75	73	PRO+G75-76N RH PV	75.1	75.1	72.8	72.8	110	71-7/8	60-1/8	26-1/4	14-1/2	11	53-1/4	1	330	0.59

*Refer to Specification Sheet on Rheem.com for LP model numbers.

Uniform Energy Factor and rated gallon capacity based on Department of Energy (DOE) requirements.

**Recovery Capacity is based upon a 100° F water temperature rise and calculated per ANSI Z21.10.3 standards.

- 160° F Max. temperature setting.
- Features side water connections for space heating applications.

Maximum and Minimum Vent Lengths for 3" and 4" Vents

FROM SEA LEVEL THROUGH 8,500 FEET ABOVE SEA LEVEL				
MODEL	VENT SYSTEM DIAMETER	MIN. ALLOWED EQUIVALENT VENT LENGTHS (EACH PIPE RUN)	MAX. ALLOWED EQUIVALENT VENT LENGTHS (EACH PIPE RUN)	VENT SYSTEM TERMINATION(S)
75-Gallon	3 Inches	10 Feet	50 Feet	90° Elbow
	4 Inches	10 Feet	100 Feet	90° Elbow

For the 3" and 4" vent, one 90° elbow is approximately equal to 5 feet of pipe. One 45° elbow is approximately equal to 2.5 feet of pipe.

NOTICE: The mixing of 3" and 4" vent pipe is not recommended. If 4" pipe is used, a 3" to 4" reducer fitting is recommended at the rubber coupling.

This water heater is supplied with a 3" Schedule 40 PVC 90° vent terminal. When venting with 4" pipe, a Schedule 40 PVC 90° vent terminal must be used. Screens for both 3" and 4" vent terminals have been included.

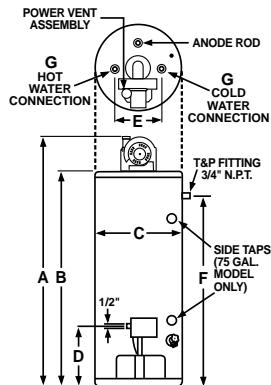

Professional Classic Plus® Powered Damper Ultra Low NOx

Efficiency

- .64 - .68 UEF
- ENERGY STAR® rated

Performance

- FHR: 86 gallons for 50-gallon model and 67 gallons for 40-gallon
- Recovery: 38 GPH at a 90° F rise

Self-Diagnostic System

- Electronic gas control for improved monitoring and service

Low Emissions

- Ultra Low NOx 38,000 BTU/h burner
- Meets 10 ng/J NOx requirements
- SCAQMD Rule 1121 compliant

Technology

- 24 VAC flue damper, 110 VAC outlet required
- Includes 19-foot cord, 3-prong plug
- Standard Cat. I, double-wall, B-vent, 3" (4" adaptor included)

Longer Life

- Premium grade anode rod provides long-lasting tank protection

Guardian System® & Sensor

- Exclusive fuel shut-off device
- Maintenance free – no filter to clean
- Disables the heater in the presence of flammable vapor accumulation

High Altitude Compliant

- Certified to 5,250 feet above sea level

Plus...

- Dual certified for both potable water and space heating
- Enhanced flow brass drain valve
- Temperature and pressure relief valve included
- Low lead compliant
- EverKleen® patented system fights sediment build-up
- Standard replacement parts

Warranty

- 8-Year limited tank and parts warranty*
- With ProtectionPlus® the 8-year limited tank warranty becomes 12-year

*See Residential Warranty Certificate for complete information

Units meet or exceed ANSI requirements and have been tested according to D.O.E. procedures. Units meet or exceed the energy efficiency requirements of NAECA, ASHRAE standard 90, ICC Code and all state energy efficiency performance criteria.



DESCRIPTION				FEATURES			ROUGHING IN DIMENSIONS (SHOWN IN INCHES)									ENERGY INFO.
T Y P E	NOMINAL GALLON CAPACITY	RATED GALLON CAPACITY	MODEL NUMBER	GAS INPUT IN THOUS. BTU/H NAT.	RECOVERY IN G.P.H. 90° F RISE NAT.	UEF FIRST HR. DEL. G.P.H. NAT.	HT. TO VENT A	TANK HEIGHT B	DIAM. C	HT. TO GAS CONN. D	VENT SIZE E	WATER CONN. CENTER F	HT. TO SIDE T&P VALVE G	WATER CONN. SIZE H	SHIP WT. (LBS)	UNIFORM ENERGY FACTOR (UEF)
Tall	40	38	★ PRO+G40-38U RH67 PD	38	38	67	65	60-1/4	19-3/4	13	3 or 4	8	53-1/2	3/4	140	0.64
Tall	50	48	★ PRO+G50-38U RH67 PD	38	38	86	64	59-1/4	21-3/4	13	3 or 4	8	52-1/2	3/4	150	0.68

Uniform Energy Factor and rated gallon capacity based on Department of Energy (DOE) requirements.

★ **ENERGY STAR®** compliant model.

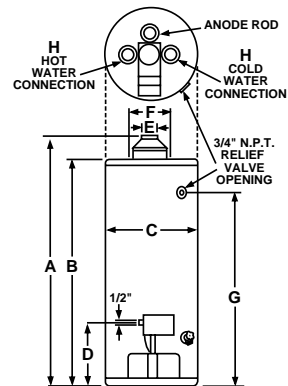

Professional Classic Plus® Ultra Low NOx

Efficiency

- .58 - .64 UEF
- More hot water at a low operating cost

Performance

- FHR: 51 - 99 gallons for natural gas
- Recovery: Up to 45 GPH at a 90° F rise, depending on model

Guardian System® & Sensor

- Exclusive fuel shut-off device
- Maintenance free – no filter to clean
- Protective control system that disables the heater in the presence of flammable vapor accumulation

Low Emissions

- Ultra Low NOx radiant burner design
- Stainless steel burner construction
- SCAQMD Rule 1121 compliant
- Meets 10 ng/J NOx requirements

High Altitude Compliant

- All models certified to 10,000 feet above sea level

Plus...

- EverKleen® patented system fights sediment build-up
- Premium grade anode rod provides long-lasting tank protection
- Easy to light – no matches required
- Enhanced-flow brass drain valve
- Temperature and pressure relief valve included
- Factory installed temperature and pressure relief valve on select models**
- Low lead compliant
- Exclusive Rheemglas® lining

Warranty

- 8-Year limited tank and parts warranty*
- With ProtectionPlus® the 8-year limited tank warranty becomes 12-year

*See Residential Warranty Certificate for complete information

Units meet or exceed ANSI requirements and have been tested according to D.O.E. procedures. Units meet or exceed the energy efficiency requirements of NAECA, ASHRAE standard 90, ICC Code and all state energy efficiency performance criteria.



Models with installed Top T&P Valve



ANSI CERTIFIED



LEED Point = 1

DESCRIPTION				FEATURES			ROUGHING IN DIMENSIONS (SHOWN IN INCHES)									ENERGY INFO.
T Y P E	NOMINAL GALLON CAPACITY	RATED GALLON CAPACITY	MODEL NUMBER	GAS INPUT IN THOUS. BTU/H NAT.	RECOVERY IN G.P.H. 90° F RISE NAT.	UEF FIRST HR. DEL. G.P.H. NAT.	HEIGHT TO VENT A	TANK HEIGHT B	DIAM. C	HT. TO GAS CONN. D	VENT SIZE E	WATER CONN. CENTER F	HT. TO SIDE T&P VALVE G	WATER CONN. SIZE H	SHIP WT. (LBS)	UNIFORM ENERGY FACTOR (UEF)
Tall	29	28	PRO+G29-30U RH63 EC1	30	30	51	59-3/4	56-7/8	16-1/2	14	3 or 4	8	50-7/8	3/4	112	0.60
Tall	40	38	PRO+G40-38U RH62 EC1**	38	38	71	61-1/2	58-1/2	19	14	3 or 4	8	52-1/4	3/4	135	0.58
Tall	50	48	PRO+G50-38U RH62 EC1**	38	38	84	61-1/4	58-3/8	23	14	3 or 4	8	51-3/8	3/4	162	0.64
Tall	55	55	PRO+G55-45U RH59 EC1	45	45	99	59-1/4	59-1/4	23-3/4	14	4	8	48-3/4	3/4	188	0.62

Uniform Energy Factor and rated gallon capacity based on Department of Energy (DOE) requirements.

**Models are available with factory installed top T&P valve, add TT to end of model number.

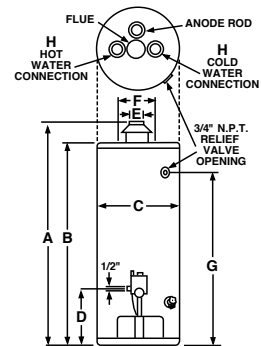

Professional Classic Plus® Heavy Duty Ultra Low NOx

Performance

- Recovery Capacity: 72.8 gallons per hour (delivers approximately 120 gallons of hot water in the first hour)**

Flammable Vapor Detection System

- Disables the heater in the presence of flammable vapors
- Maintenance free – no filter to clean

High Altitude Compliant

- All models are certified for applications up to 8,500 feet above sea level

Plus...

- Integrated self diagnostic system control for easy installation and service
- Eco-friendly burner, ultra low NOx design meets 14 ng/J NOx requirements
- Premium grade anode rod provides long-lasting tank protection
- Enhanced-flow brass drain valve
- Temperature and pressure relief valve included
- Low lead compliant
- Side water connections for space heating applications
- Standard replacement parts
- Standard 110-volt electrical connection
- Durable silicon nitride igniter – Hot Surface Ignition (HSI)

Warranty

- 8-Year limited tank and parts warranty*
- With ProtectionPlus® the 8-year limited tank warranty becomes 12-year

*See Warranty Certificate for complete information

Efficiency | All models tested according to ANSI test procedures, and meet or exceed the thermal efficiency and standby loss requirements of current ASHRAE standard (EPact). Also exceeds energy efficiency codes of all states including California Energy Commission (CEC).

Safety and Construction | Design certified by CSA: For operation at 160 degrees; meets all safety and construction requirements of ANSI Z21.10.3; as an automatic storage or instantaneous water heater; as an automatic circulating tank water heater; and for operation on combustible floors and in alcove installations. All models are North Carolina Code compliant. **Certified for 150 PSI maximum working pressure.**

2000
PROCLUB
POINTS



DESCRIPTION				FEATURES			ROUGHING IN DIMENSIONS (SHOWN IN INCHES)										ENERGY INFO.
T Y P E	NOMINAL GALLON CAPACITY	RATED GALLON CAPACITY	MODEL NUMBER	GAS INPUT IN THOUS. BTU/H NAT.	RECOVERY IN G.P.H. 100° F RISE** NAT.	UEF FIRST HR. DELIVERY G.P.H.	HEIGHT TO VENT A	TANK HEIGHT B	DIAM. C	HT. TO GAS CONN. D	VENT SIZE E	WATER CONN. CENTER F	HT. TO SIDE T&P VALVE G	WATER CONN. SIZE H	FRONT TO BACK I	SHIP WT. (LBS)	UNIFORM ENERGY FACTOR (UEF)
Tall	75	73	PRO+G75-75U RH	75.1	72.8	120	64-1/8	60-1/4	26-1/4	14-1/4	4	11	52-1/4	1	33-3/4	300	0.68
Tall	98	93	PRO+G98-75U RH	75.1	72.8	120	67-7/8	64	27-1/8	14-1/4	4	11	56-1/8	1	34-3/4	370	0.65

**Recovery Capacity is based upon a 100° F water temperature rise and calculated per ANSI Z21.10.3 standards.
Uniform Energy Factor and rated gallon capacity based on Department of Energy (DOE) requirements.

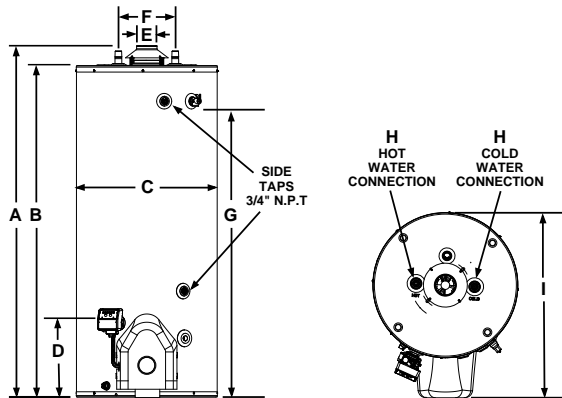

Professional Classic® Atmospheric

Efficiency

- .58 - .66 UEF
- More hot water at a low operating cost

Performance

- FHR: 51 to 87 gallons
- Recovery: 30.3 to 40.4 GPH at a 90° F rise, depending on model

Guardian System® & Sensor

- Exclusive air/fuel shut-off device
- Maintenance free – no filter to clean
- Disables the heater in the presence of flammable vapor accumulation

Low Emissions

- Eco-friendly burner, low NOx design
- Meets 40 ng/J NOx requirements

Longer Life

- Premium grade anode rod provides long-lasting tank protection

Altitude Certification

- All models certified up to 5,999 feet above sea level, some certified up to 10,000. Consult factory for specifications

Plus...

- Easy to light – no matches required
- EverKleen® patented system fights sediment build-up
- Exclusive Rheemglas® tank lining resists corrosion and prolongs tank life
- Enhanced-flow brass drain valve
- Temperature and pressure relief valve included
- Factory installed temperature and pressure relief valve on select models**
- Low lead compliant
- Standard replacement parts

Warranty

- 6-Year limited tank and parts warranty*
- With ProtectionPlus® the 6-year limited tank warranty becomes 10-year

*See Residential Warranty Certificate for complete information

Units meet or exceed ANSI requirements and have been tested according to D.O.E. procedures. Units meet or exceed the energy efficiency requirements of NAECA, ASHRAE standard 90, ICC Code and all state energy efficiency performance criteria.

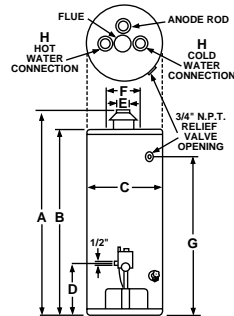

Models with installed Top T&P Valve

DESCRIPTION				FEATURES						ROUGHING IN DIMENSIONS (SHOWN IN INCHES)									ENERGY INFO.
TYPE	NOMINAL GALLON CAPACITY	RATED GALLON CAPACITY	NAT. GAS MODEL NUMBER*	GAS INPUT IN THOUS. BTU/H		RECOVERY IN G.P.H. 90° F RISE		UEF FIRST HR. DEL. G.P.H.		HEIGHT TO VENT A	TANK HEIGHT B	DIAM. C	HT. TO GAS CONN. D	VENT SIZE E	WATER CONN. CENTER F	HT. TO SIDE T&P VALVE G	WATER CONN. SIZE H	SHIP WT. (LBS)	UNIFORM ENERGY FACTOR (UEF)
				NAT.	LP	NAT.	LP	NAT.	LP										
Tall	29	28	PROG29-32N RH63	32	30	32.3	30.3	63	63	59-3/4	56-7/8	16-1/2	14-1/4	3 or 4	8	50-3/4	3/4	110	0.60
Tall	40	38	PROG40-36N RH62†	36	-	36.4	-	64	-	61-1/2	58-1/2	19	14-1/4	3 or 4	8	52-1/4	3/4	127	0.58
Tall	40	38	PROG40-38N RH62†**	38	-	38.4	-	64	-	61-1/2	58-1/2	19	14-1/4	3 or 4	8	52-1/4	3/4	127	0.58
Tall	40	38	PROG40-40N RH62†**	40	36	40.4	36.3	84	84	63-1/4	60	19-1/2	14	3 or 4	8	53-1/2	3/4	135	0.66
Tall	40	38	PROG40-32P RH62†	-	32	-	32.3	-	67	61-1/2	58-1/2	18-1/2	14-1/4	3 or 4	8	52-1/4	3/4	125	0.59
Tall	50	48	PROG50-40N RH62†**	40	36	40.4	36.4	76	76	62-1/2	59-1/4	21-1/2	14-1/2	3 or 4	8	52-1/2	3/4	165	0.65
Tall	50	48	PROG50-38N RH60†**	38	36	38.4	36.4	85	85	61-1/4	58-3/8	20-1/2	14-1/4	3 or 4	8	51-3/8	3/4	150	0.64
Short	30	29	PROG30S-30N RH63	30	-	30.3	-	51	-	49-7/8	47	19-3/4	14-1/4	3 or 4	8	40-3/8	3/4	112	0.60
Short	40	38	PROG40S-40N RH62†	40	36	40.4	36.4	52	52	53-7/8	50-1/2	23	14-1/2	3	8	44	3/4	135	0.58
Short	40	39	PROG40S-38N RH62†	38	35	38.4	35.4	65	65	53-1/4	50-1/4	21-3/8	14-1/4	3 or 4	8	44	3/4	125	0.58
Short	50	48	PROG50S-40N RH61†	40	36	40.4	36.4	87	87	54-1/4	51-1/8	23-3/4	14-1/4	3 or 4	8	44	3/4	186	0.63

*Refer to Specification Sheet on Rheem.com for LP model numbers.

Uniform Energy Factor and rated gallon capacity based on Department of Energy (DOE) requirements.

**Models are available with factory installed top T&P valve, add TT to end of model number.



†LEED Point = 1



Professional Classic® Power Vent

Efficiency

- .65 - .70 UEF
- ENERGY STAR® rated

Performance

- FHR: 65 - 86 gallons
- Recovery: 32.4 to 42.4 GPH at a 90° F rise

Self-Diagnostic System

- Electronic gas control for improved monitoring and service

Low Emissions

- Eco-friendly burner, low NOx design

Features

- Uses indoor air for combustion; blower exhausts the flue gases
- Standard 120 VAC electrical connection
- New whisper quiet blower

Guardian System™ & Sensor

- Exclusive air/fuel shut-off device
- Maintenance free – no filter to clean
- Protective control system that disables the heater in the presence of flammable vapor accumulation

Flexible Venting Options

- Long venting lengths up to 150 equivalent feet
- PVC, ABS, or CPVC vent pipe options
- Vertical or horizontal termination

Longer Life

- Premium grade anode rod provides long-lasting tank protection

High Altitude Compliant

- All models certified for applications up to 7,800 ft. above sea level

Plus...

- Enhanced flow brass drain valve
- Temperature and pressure relief valve included
- Low lead compliant
- Durable Silicon Nitride Ignitor (HSI)
- EverKleen® patented system fights sediment build-up
- Standard replacement parts

Warranty

- 6-Year limited tank and parts warranty*
- With ProtectionPlus® the 6-year limited tank warranty becomes 10-year

*See Residential Warranty Certificate for complete information

Units meet or exceed ANSI requirements and have been tested according to D.O.E. procedures. Units meet or exceed the energy efficiency requirements of NAECA, ASHRAE standard 90, ICC Code and all state energy efficiency performance criteria.



LEED Point = 1

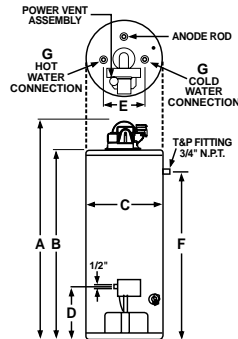

DESCRIPTION				FEATURES						ROUGHING IN DIMENSIONS (SHOWN IN INCHES)								ENERGY INFO.
TYPE	NOMINAL GALLON CAPACITY	RATED GALLON CAPACITY	NAT. GAS MODEL NUMBER*	GAS INPUT IN THOUS. BTU/H		RECOVERY IN G.P.H. 90° F RISE		UEF FIRST HR. DEL. G.P.H.		HEIGHT TO TOP OF ASSEMBLY A	TANK HEIGHT B	DIAM. C	HT. TO GAS CONN. D	WATER CONN. CENTER E	HT. TO SIDE T&P VALVE F	WATER CONN. SIZE G	SHIP WT. (LBS)	UNIFORM ENERGY FACTOR (UEF)
				NAT.	LP	NAT.	LP	NAT.	LP									
Tall	40	38	★ PROG40-40N RH67 PV	40	–	40.4	–	86	–	66-1/4	59	19-3/4	14	8	53-1/2	3/4	137	0.69
Tall	50	48	★ PROG50-42N RH67 PV	42	–	42.4	–	78	–	65-1/2	58	21-3/4	14	8	52-1/2	3/4	170	0.68
Short	40	39	★ PROG40S-36N RH67 PV	36	–	36.4	–	66	–	58-1/4	51-1/4	21-3/4	14	8	44-1/4	3/4	161	0.65
Short	50	48	★ PROG50S-36N RH67 PV	36	–	36.4	–	78	–	58-1/4	51-1/4	23-3/4	14	8	44	3/4	185	0.70

*Refer to Specification Sheet on Rheem.com for LP model numbers.

Uniform Energy Factor and rated gallon capacity based on Department of Energy (DOE) requirements.

★ ENERGY STAR® compliant model.

MAXIMUM AND MINIMUM VENT LENGTHS FOR 2 - 3" VENTS UP TO 2,000 FT. (609 M) ABOVE SEA LEVEL								
MODEL	GAS	HEATER INPUT	VENT SYSTEM DIAMETER	MIN. ALLOWED EQUIVALENT VENT LENGTH		MAX ALLOWED EQUIVALENT VENT LENGTH		VENT SYSTEM TERM.
				FEET	METERS	FEET	METERS	
All	Natural & Propane	42,000, 40,000, 36,000, 32,000	2	7	2.1	55	16.7	45° Elbow
			3	7	2.1	150	45.7	45° Elbow

For the 2" and 3" vent, one 90° elbow is approximately equal to 5 feet of pipe.
One 45° elbow is approximately equal to 2.5 feet of pipe.

MAXIMUM AND MINIMUM VENT LENGTHS FOR 2 - 3" VENTS FROM 2,000 FT. (609 M) THROUGH 7,800 FT. (2,377 M) ABOVE SEA LEVEL								
MODEL	GAS	HEATER INPUT	VENT SYSTEM DIAMETER	MIN. ALLOWED EQUIVALENT VENT LENGTH		MAX ALLOWED EQUIVALENT VENT LENGTH		VENT SYSTEM TERM.
				FEET	METERS	FEET	METERS	
40 Gallon	Natural	40,000	2	7	2.1	25	7.6	45° Elbow
			3	7	2.1	150	45.7	45° Elbow
40 Gallon	Propane	36,000	2	7	2.1	35	10.6	45° Elbow
			3	7	2.1	150	45.7	45° Elbow
40 Gallon	Natural & Propane	36,000, 32,000	2	7	2.1	40	12.2	45° Elbow
			3	7	2.1	150	45.7	45° Elbow
50 Gallon	Natural & Propane	42,000, 36,000, 32,000	2	7	2.1	35	10.6	45° Elbow
			3	7	2.1	150	45.7	45° Elbow



Professional Classic® Power Direct Vent

Efficiency

- .63 - .69 UEF
- ENERGY STAR® rated

Performance

- FHR: Up to 82 gallons for natural and LP gas
- Recovery: 38.4 to 40.4 GPH at a 90° F rise, depending on model

Self-Diagnostic System

- Electronic gas control for improved monitoring and service

Low Emissions

- Eco-friendly burner, low NOx design

Features

- Two pipe system: one pipe pulls in outside air for combustion and the other exhausts combustion gases
- 120 VAC powered blower
- New whisper quiet blower

Flammable Vapor Detection System

- Disables the heater in the presence of flammable vapors

Flexible Venting Options

- Long venting lengths up to 100 feet
- PVC, ABS, or CPVC vent pipe options
- Vertical or horizontal termination
- Concentric vent kit available

Longer Life

- Premium grade anode rod provides long-lasting tank protection

High Altitude Compliant

- Models are certified for applications up to 10,200 feet above sea level

Plus...

- Enhanced-flow brass drain valve
- Temperature and pressure relief valve included
- Low lead compliant
- Durable silicon nitride igniter (HSI)
- EverKleen® patented system fights sediment build-up
- Standard replacement parts

Warranty

- 6-Year limited tank and parts warranty*
- With ProtectionPlus® the 6-year limited tank warranty becomes 10-year

*See Residential Warranty Certificate for complete information

Units meet or exceed ANSI requirements and have been tested according to D.O.E. procedures. Units meet or exceed the energy efficiency requirements of NAECA, ASHRAE standard 90, ICC Code and all state energy efficiency performance criteria.

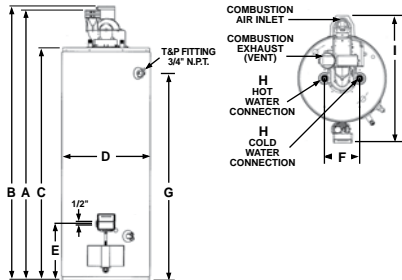

DESCRIPTION				FEATURES						ROUGHING IN DIMENSIONS (SHOWN IN INCHES)										ENERGY INFO.
TYPE	NOMINAL GALLON CAP.	RATED GALLON CAP.	NAT. GAS MODEL NUMBER*	GAS INPUT IN THOUS. BTU/H		RECOVERY IN G.P.H. 90° F RISE		UEF FIRST HR. DEL. G.P.H.		HEIGHT TO TOP OF VENT A	HEIGHT TO TOP OF AIR INLET B	TANK HEIGHT C	DIAM. D	HT. TO GAS CONN. E	WATER CONN. CNTR. F	HT. TO SIDE T&P VALVE G	WATER CONN. SIZE H	FRONT TO BACK I	SHIP WT. (LBS)	UNIFORM ENERGY FACTOR (UEF)
				NAT.	LP	NAT.	LP	NAT.	LP											
Tall	40	38	★ PROG40-40N RH67 PDV	40	38	40.4	38.4	67	67	68-1/2	69-1/4	60-1/4	19-3/4	14	8	53-3/4	3/4	29-1/2	180	0.63
Tall	50	47	★ PROG50-40N RH67 PDV	40	40	40.4	40.4	82	82	67-5/8	67-7/8	59-3/8	21-3/4	14	8	52-3/4	3/4	31-1/2	205	0.69

*Refer to Specification Sheet on Rheem.com for LP model numbers.

Uniform Energy Factor and rated gallon capacity based on Department of Energy (DOE) requirements.

★ ENERGY STAR® compliant model.

Air-Inlet and Venting Information – See Next Page.



Professional Classic® Power Direct Vent

Air-Inlet and Venting Information

FROM SEA LEVEL THROUGH 5,999 FEET ABOVE SEA LEVEL					
MODEL	VENT & COMBUSTION AIR-INLET SYSTEM DIAMETER (INCHES)	MIN. ALLOWED EQUIV. VENT & COMBUSTION AIR-INLET LENGTHS – EACH PIPE RUN (FT.)	MAX. ALLOWED EQUIV. VENT & COMBUSTION AIR-INLET LENGTHS – EACH PIPE RUN (FT.)	VENT AND COMBUSTION AIR-INLET SYSTEM TERMINATION(S)	
PROG40-40N RH67 PDV	2	7	30	90° Elbows	Concentric*
PROG40-40N RH67 PDV	3	7	60	90° Elbows	–
PROG40-40N RH67 PDV	3	7	50	–	Concentric*
PROG50-40N RH67 PDV	2	7	30	90° Elbows	Concentric*
PROG50-40N RH67 PDV	3	7	60	90° Elbows	–
PROG50-40N RH67 PDV	3	7	50	–	Concentric*

FROM 6,000 FEET ABOVE SEA LEVEL THROUGH 7,700 FEET ABOVE SEA LEVEL					
MODEL	VENT & COMBUSTION AIR-INLET SYSTEM DIAMETER (INCHES)	MIN. ALLOWED EQUIV. VENT & COMBUSTION AIR-INLET LENGTHS – EACH PIPE RUN (FT.)	MAX. ALLOWED EQUIV. VENT & COMBUSTION AIR-INLET LENGTHS – EACH PIPE RUN (FT.)	VENT AND COMBUSTION AIR-INLET SYSTEM TERMINATION(S)	
PROG40-40N RH67 PDV	2	7	15	90° Elbows	–
PROG40-40N RH67 PDV	2	7	30	–	Concentric*
PROG40-40N RH67 PDV	3	7	60	90° Elbows	–
PROG40-40N RH67 PDV	3	7	50	–	Concentric*
PROG50-40N RH67 PDV	2	7	15	–	Concentric*
PROG50-40N RH67 PDV	3	7	60	90° Elbows	–
PROG50-40N RH67 PDV	3	7	50	–	Concentric*

Air-Inlet and Venting Information

FROM 7,701 FEET ABOVE SEA LEVEL THROUGH 10,200 FEET ABOVE SEA LEVEL					
MODEL	VENT & COMBUSTION AIR-INLET SYSTEM DIAMETER (INCHES)	MIN. ALLOWED EQUIV. VENT & COMBUSTION AIR-INLET LENGTHS – EACH PIPE RUN (FT.)	MAX. ALLOWED EQUIV. VENT & COMBUSTION AIR-INLET LENGTHS – EACH PIPE RUN (FT.)	VENT AND COMBUSTION AIR-INLET SYSTEM TERMINATION(S)	
PROG40-40N RH67 PDV	2	7	15	–	Concentric*
PROG40-40N RH67 PDV	3	7	60	90° Elbows	–
PROG40-40N RH67 PDV	3	7	50	–	Concentric*
PROG50-40N RH67 PDV	3	7	60	90° Elbows	–
PROG50-40N RH67 PDV	3	7	50	–	Concentric*

One 90° elbow is approximately equivalent to 5 feet of pipe. One 45° elbow is approximately equivalent to 2.5 feet of pipe.

* Use only Rheem 3 inch concentric termination.



Professional *Classic*® Direct Vent

Efficiency

- .51 - .56 UEF
- Well insulated for reduced stand-by heat loss

Performance

- FHR: 80 gallons for 50-gallon model and 62 gallons for 40-gallon model
- Recovery: 30.3 to 36.4 GPH at a 90° F rise, depending on model

Technology

- Adjustable coaxial vent allows flexibility of installation, can swivel 360 degrees and uses outside air for combustion and requires no electrical power
- Aluminum vent and cap base to prevent staining of building exterior

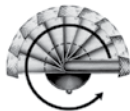

Longer Venting

- Up to 4 feet above the water heater and 4 feet from an outside wall
- Order Horizontal Vent Kit: #SP20131
- Order Vertical Vent Kit: #SP20132

Altitude Certification

- All models certified up to 5,999 feet above sea level

Low Emissions

- Meets 40 ng/J NOx requirements

Longer Life

- Premium grade anode rod provides long-lasting tank protection

Plus...

- Enhanced-flow brass drain valve
- Temperature and pressure relief valve included
- Low lead compliant
- Exclusive Rheemglas® tank lining resists corrosion and prolongs tank life
- Heat saving flue baffle design
- Gas control and combination thermostat
- Piezo ignition
- High temperature silicone bands reduce venting installation time
- Internal air tube for reduced footprint
- EverKleen® patented system fights sediment build-up

Warranty

- 6-Year limited tank and parts warranty*
- With ProtectionPlus® the 6-year limited tank warranty becomes 10-year

*See Residential Warranty Certificate for complete information

Units meet or exceed ANSI requirements and have been tested according to D.O.E. procedures. Units meet or exceed the energy efficiency requirements of NAECA, ASHRAE standard 90, ICC Code and all state energy efficiency performance criteria.



ANSI CERTIFIED



LEED Point = 1

DESCRIPTION				FEATURES						ROUGHING IN DIMENSIONS (SHOWN IN INCHES)						ENERGY INFO.	
TYPE	NOMINAL GALLON CAPACITY	RATED GALLON CAPACITY	NAT. GAS MODEL NUMBER*	GAS INPUT IN THOUS. BTU/H		RECOVERY IN G.P.H. 90° F RISE		UEF FIRST HR. DEL. G.P.H.		HEIGHT TO VENT A	TANK HEIGHT B	DIAM. C	HT. TO GAS CONN. D	VENT SIZE E	HT. TO SIDE T&P VALVE F	SHIP WT. (LBS)	UNIFORM ENERGY FACTOR (UEF)
				NAT.	LP	NAT.	LP	NAT.	LP								
Tall	40	38	PROG40-36N RH62 DV	36	30	36.4	30.3	62	62	68-1/4	60-7/8	19-3/4	14-1/4	6	51-5/8	155	0.56
Tall	50	48	PROG50-36N RH60 DV	36	33	36.4	33.3	80	80	68	59-5/8	21-3/4	14-1/4	6	52-1/2	165	0.51

*Refer to Specification Sheet on Rheem.com for LP model numbers.

Uniform Energy Factor and rated gallon capacity based on Department of Energy (DOE) requirements.

VENTING - ROUGHING IN DIMENSIONS (INCHES)			SIDE VENTING (G) WITH INCLUDED VENT KIT		SIDE VENTING (G) WITH OPTIONAL VENT KIT		OPTIONAL HEIGHT (A) WITH VENT KIT
TYPE	MODEL NUMBER	4 FEET VENTING AVAILABLE	MIN.	MAX.	MIN.	MAX.	
Tall	PROG40-38N RH62 DV	Horiz. & Vertical	9-1/8	19-1/8	9-1/8	48**	68-1/4 - 107-3/4†
Tall	PROG50-38N RH60 DV	Horiz. & Vertical	8-1/8	18-1/8	8-1/8	48**	68 - 107†

**Horizontal Vent Kit #SP20131 for applications up to 2,000 feet above sea level. Optional horizontal venting not applicable for installations above 2,000 feet. Venting dimensions are approximate.

†Vertical Vent Kit #SP20132. Venting dimensions are approximate.

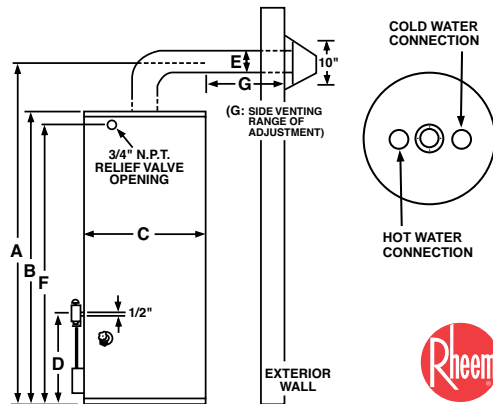

Professional Classic® Ultra Low NOx

Efficiency

- .58 - .64 UEF
- More hot water at a low operating cost

Performance

- FHR: 51 - 86 gallons for natural gas
- Recovery: 30 to 38 GPH at a 90° F rise, depending on model

Guardian System® & Sensor

- Exclusive fuel shut-off device
- Maintenance free – no filter to clean
- Protective control system that disables the heater in the presence of flammable vapor accumulation

Low Emissions

- Ultra Low NOx radiant burner design
- Stainless steel construction
- SCAQMD Rule 1121 compliant
- Meets 10 ng/J NOx requirements

Self-Cleaning

- EverKleen® patented system fights sediment build-up
- Reduces fuel costs
- Provides more hot water

Easy to Light

- No matches required

Longer Life

- Premium grade anode rod provides long-lasting tank protection

Altitude Certification

- All models certified up to 10,000 feet above sea level

Plus...

- Enhanced-flow brass drain valve
- Temperature and pressure relief valve included
- Factory installed temperature and pressure relief valve on select models**
- Low lead compliant
- Exclusive Rheemglas® lining

Warranty

- 6-Year limited tank and parts warranty*
- With ProtectionPlus® the 6-year limited tank warranty becomes 10-year

*See Residential Warranty Certificate for complete information

Units meet or exceed ANSI requirements and have been tested according to D.O.E. procedures. Units meet or exceed the energy efficiency requirements of NAECA, ASHRAE standard 90, ICC Code and all state energy efficiency performance criteria.



Models with installed Top T&P Valve



ANSI CERTIFIED



LEED Point = 1

DESCRIPTION				FEATURES			ROUGHING IN DIMENSIONS (SHOWN IN INCHES)									ENERGY INFO.
T Y P E	NOMINAL GALLON CAPACITY	RATED GALLON CAPACITY	MODEL NUMBER	GAS INPUT IN THOUS. BTU/H NAT.	RECOVERY IN G.P.H. 90° F RISE NAT.	UEF FIRST HR. DEL. G.P.H. NAT.	HEIGHT TO VENT A	TANK HEIGHT B	DIAM. C	HT. TO GAS CONN. D	VENT SIZE E	WATER CONN. CENTER F	HT. TO SIDE T&P VALVE G	WATER CONN. SIZE H	SHIP WT. (LBS)	UNIFORM ENERGY FACTOR (UEF)
Tall	29	28	PROG29-30U RH63 EC1	30	30	51	59-3/4	56-7/8	16-1/2	14	3 or 4	8	50-7/8	3/4	112	0.60
Tall	40	38	PROG40-38U RH62 EC1**	38	38	71	61-1/2	58-1/2	19	14	3 or 4	8	52-1/4	3/4	127	0.58
Tall	50	48	PROG50-38U RH60 EC1**	38	38	86	61-1/4	58-3/8	20-1/2	14	3 or 4	8	51-3/8	3/4	162	0.63
Tall	50	48	PROG50-38U RH62 EC1	38	38	84	61-1/4	58-3/8	23	14	3 or 4	8	51-3/8	3/4	162	0.64
Short	39	37	PROG39S-38U RH62 EC1	38	38	68	52-1/8	49-1/4	21	14	3 or 4	8	42-3/4	3/4	135	0.59
Short	50	48	PROG50S-40U RH60 EC1	40	40	85	54-1/4	51-1/8	23-3/4	14	3 or 4	8	44-1/4	3/4	186	0.63

Uniform Energy Factor and rated gallon capacity based on Department of Energy (DOE) requirements.

**Models are available with factory installed top T&P valve, add TT to end of model number.

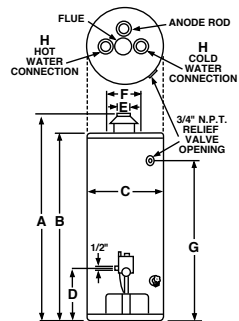

Professional Classic® Power Vent Ultra Low NOx

Efficiency

- .64 - .68 UEF
- ENERGY STAR® rated
- More hot water at a low operating cost

Performance

- FHR: 67 - 86 gallons for natural gas
- Recovery: 36.4 to 38.4 GPH at a 90° F rise, depending on model

Guardian System® & Sensor

- Exclusive air/fuel shut-off device for double protection
- Maintenance free – no filter to clean
- Disables the heater in the presence of flammable vapor accumulation

Low Emissions

- Ultra Low NOx radiant burner design
- Stainless steel construction
- SCAQMD Rule 1121 compliant
- Meets 10 ng/J NOx requirements

Self-Cleaning

- EverKleen® patented system fights sediment build-up
- Reduces fuel costs
- Provides more hot water

Flexible Venting Options

- Long venting lengths up to 100 feet
- PVC, ABS, or CPVC vent pipe options
- Vertical or horizontal termination

Longer Life

- Premium grade anode rod provides long-lasting tank protection

High Altitude Compliant

- Certified to 5,999 feet above sea level

Plus...

- Whisper quiet blower
- Enhanced-flow brass drain valve
- Temperature and pressure relief valve included
- Low lead compliant
- Durable spark-to-pilot ignitor

Warranty

- 6-Year limited tank and parts warranty*
- With ProtectionPlus® the 6-year limited tank warranty becomes 10-year

*See Residential Warranty Certificate for complete information

Units meet or exceed ANSI requirements and have been tested according to D.O.E. procedures. Units meet or exceed the energy efficiency requirements of NAECA, ASHRAE standard 90, ICC Code and all state energy efficiency performance criteria.



ANSI CERTIFIED



LEED Point = 1



DESCRIPTION				FEATURES			ROUGHING IN DIMENSIONS (SHOWN IN INCHES)							ENERGY INFO.	
T Y P E	NOMINAL GALLON CAPACITY	RATED GALLON CAPACITY	MODEL NUMBER	GAS INPUT IN THOUS. BTU/H NAT.	RECOVERY IN G.P.H. 90° F RISE NAT.	UEF FIRST HR. DEL. G.P.H. NAT.	HT. TO TOP OF ASSEMBLY A	TANK HEIGHT B	DIAM. C	HT. TO GAS CONN. D	WATER CONN. CENTER E	HT. TO SIDE T&P VALVE F	WATER CONN. SIZE G	SHIP WT. (LBS)	UNIFORM ENERGY FACTOR (UEF)
Tall	40	38	★ PROG40-36U RH67 PV-1	36	36.4	67	67-3/8	59	19-3/4	14	8	53-1/2	3/4	160	0.64
Tall	50	48	★ PROG50-38U RH67 PV-1	38	38.4	86	66-3/8	58	21-3/4	14	8	52-1/2	3/4	188	0.68

Uniform Energy Factor and rated gallon capacity based on Department of Energy (DOE) requirements.

★ **ENERGY STAR®** compliant model.

Maximum and Minimum Vent Lengths for 2" Vents

NUMBER OF 90° ELBOWS WITH VENT TERMINAL	NUMBER OF 45° ELBOWS	MINIMUM PIPE LENGTH REQ. (FT.)	MAXIMUM PIPE LENGTH (FT.)
One (1)	None	3.0	44.0
One (1)	One (1)	3.0	41.0
Two (2)	None	3.0	38.0
Two (2)	One (1)	3.0	35.0
Three (3)	None	3.0	32.0

For the 2" vent, one 90° elbow is approximately equal to 6 feet of pipe.
One 45° elbow is approximately equal to 3 feet of pipe.

NOTICE: The mixing of 2" and 3" vent pipe is not recommended. If 3" pipe is used, a 2" to 3" reducer fitting is recommended at the rubber coupling.

This water heater is supplied with a 2" Schedule 40 PVC 45° vent terminal.
When venting with 3" pipe, a Schedule 40 PVC 45° vent terminal must be used.
Screens for both 2" and 3" vent terminals have been included.

Maximum and Minimum Vent Lengths for 3" Vents

NUMBER OF 90° ELBOWS WITH VENT TERMINAL	NUMBER OF 45° ELBOWS	MINIMUM PIPE LENGTH REQ. (FT.)	MAXIMUM PIPE LENGTH (FT.)
One (1)	None	3.0	95.0
One (1)	One (1)	3.0	92.5
Two (2)	None	3.0	90.0
Two (2)	One (1)	3.0	87.5
Three (3)	None	3.0	85.0
Three (3)	One (1)	3.0	82.5
Four (4)	None	3.0	80.0
Four (4)	One (1)	3.0	77.5
Five (5)	None	3.0	75.0

For the 3" vent, one 90° elbow is approximately equal to 5 feet of pipe.
One 45° elbow is approximately equal to 2.5 feet of pipe.

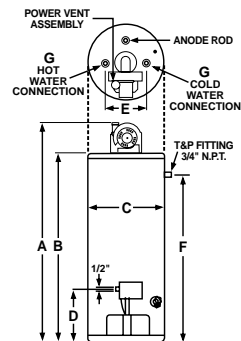

Professional *Classic*[®] Atmospheric for Manufactured Housing

Efficiency

- .59 - .60 UEF

Performance

- FHR: 57 gallons for 40-gallon model and 52 gallons for 29-gallon model
- Recovery: 30.3 to 34.3 GPH at a 90° F rise, depending on model

Longer Life

- Premium grade anode rod provides long-lasting tank protection

Guardian System[®] & Sensor

- Exclusive air/fuel shut-off device
- Maintenance free – no filter to clean
- Disables the heater in the presence of flammable vapor accumulation

Flexibility

- Field convertible controls and burner assembly for natural gas or LP operation included

Low Emissions

- Eco-friendly burner, low NOx design
- Meets 40 ng/J NOx requirements

Altitude Certification

- All models certified up to 8,400 feet above sea level
- High altitude model available for 29-Gallon (4,500 to 10,000 ft.)

Plus...

- Certified for manufactured (HUD) and modular construction
- Enhanced-flow brass drain valve
- Side inlet temperature and pressure relief valve opening
- Factory installed temperature and pressure relief valve – side location
- Low lead compliant
- Two hole top for anode rod and hot water outlet
- Exclusive Rheemglas[®] tank lining resists corrosion and prolongs tank life
- Piezo ignition – easy light pilot, no matches required
- Cold water inlet – side connection allows for quick, economical hook-up
- Optional leg kit for replacement units
- EverKleen[®] patented system fights sediment build-up

Warranty

- 6-Year limited tank and parts warranty*

*See Residential Warranty Certificate for complete information

Units meet or exceed ANSI requirements and have been tested according to D.O.E. procedures. Units meet or exceed the energy efficiency requirements of NAECA, ASHRAE standard 90, ICC Code and all state energy efficiency performance criteria.

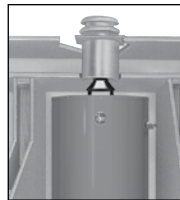

Draft Diverter

Improved design provides efficient heating with down-draft protection.



DESCRIPTION				FEATURES						ROUGHING IN DIMENSIONS (SHOWN IN INCHES)								ENERGY INFO.
TYPE	NOMINAL GALLON CAPACITY	RATED GALLON CAPACITY	MODEL NUMBER	GAS INPUT IN THOUS. BTU/H		RECOVERY IN G.P.H. 90° F RISE		UEF FIRST HR. DEL. G.P.H.		HEIGHT TO VENT A	TANK HEIGHT B	DIAM. C	HT. TO GAS CONN. D	VENT SIZE E	WATER CONN. CENTER F	HT. TO SIDE T&P VALVE G	SHIP WT. (LBS)	UNIFORM ENERGY FACTOR (UEF)
				NAT.	LP	NAT.	LP	NAT.	LP									
Tall	29	28	PROG30-32N RH63 MH	32	30	32.3	30.3	52	52	59-5/8	56-7/8	16-1/2	14-3/8	3 or 4	8	50-7/8	110	0.60
Tall	40	38	PROG40-34N RH62 MH	34	32	34.3	32.3	57	57	61-1/2	58-1/2	18-1/2	14-3/8	3 or 4	8	52-1/4	125	0.59

Uniform Energy Factor and rated gallon capacity based on Department of Energy (DOE) requirements.

ROOF JACKS PART NO.	ROOF OPENING TO FLOOR DIM.	ROOF JACK ADJ. RANGE
AP12118B*	98" Min./126" Max.	16" Min./32" Max.
AP12118C*	112" Min./154" Max.	30" Min./60" Max.
AP12118D*	130" Min./189" Max.	48" Min./95" Max.
AP12119B†	94" Min./106" Max.	12"

*Adjustable length roof jacks

†Fixed length roof jacks

Roof jack must be ordered separately with 29 and 40-gallon atmospheric models and must be in accordance with instructions furnished with the heater. Clamps and secure strapping are packed in water heater carton.

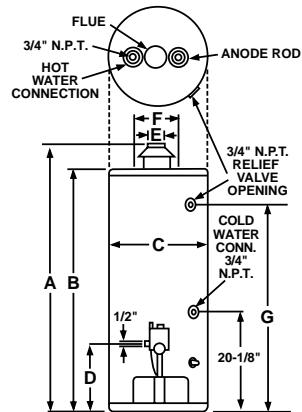

Professional *Classic*® Direct Vent for Manufactured Housing

Efficiency

- .57 - .59 UEF

Performance

- FHR: 58 gallons for 40-gallon model and 46 gallons for 30-gallon model
- Recovery: 30.3 GPH at a 90° F rise

Flexibility

- Field convertible controls for natural gas or LP operation included
- No external door is required
- Provides maximum design freedom since it can be placed anywhere within the home
- Hot water outlet located at top
- Cold water inlet at side for fast, economical hook-up

Altitude Certification

- All models certified up to 10,000 feet above sea level

Low Emissions

- Eco-friendly burner, low NOx design
- Meets 40 ng/J NOx requirements

Longer Life

- Premium grade anode rod provides long-lasting tank protection

Plus...

- Certified for manufactured (HUD) and modular construction
- Piezo ignition – easy light pilot
- Enhanced-flow brass drain valve
- Factory installed temperature and pressure relief valve – side location
- Low lead compliant
- EverKleen® patented system fights sediment build-up

Warranty

- 6-Year limited tank and parts warranty*

*See Residential Warranty Certificate for complete information

Units meet or exceed ANSI requirements and have been tested according to D.O.E. procedures. Units meet or exceed the energy efficiency requirements of NAECA, ASHRAE standard 90, ICC Code and all state energy efficiency performance criteria.

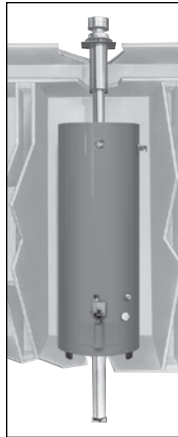

ANSI CERTIFIED



LEED Part - 1

Adjustable Roof Jack Vent

Design allows adjustment to roof pitches of up to 5/12". Four roof jacks available to accommodate roof thickness of 12" up to 95".

Direct Combustion Air Inlet

Air is drawn directly into combustion chamber through air inlet fixed to base; 1/2" screen for rodent protection.



DESCRIPTION				FEATURES			ROUGHING IN DIMENSIONS (SHOWN IN INCHES)									ENERGY INFO.
T Y P E	NOMINAL GALLON CAPACITY	RATED GALLON CAPACITY	MODEL NUMBER	GAS INPUT IN THOUS. BTU/H NAT./LP	RECOVERY IN G.P.H. 90° F RISE NAT./LP	UEF FIRST HR. DEL. G.P.H. NAT./LP	HEIGHT TO VENT A	TANK HEIGHT B	DIAM. C	HT. TO GAS CONN. D	VENT SIZE E	ROOF JACK VENT SIZE F	HT. TO SIDE T&P VALVE G	HT. TO WATER CONN. H	SHIP WT. (LBS)	UNIFORM ENERGY FACTOR (UEF)
Tall	30	29	PROG30-30N RH63 MH DV	30	30.3	46	56-5/8	56-5/8	17-3/4	14-1/8	3	5	51-1/8	20	110	0.57
Tall	40	38	PROG40-30N RH62 MH DV	30	30.3	58	57-3/8	57-3/8	19-3/4	14-1/8	3	5	51-1/8	20	125	0.59

Uniform Energy Factor and rated gallon capacity based on Department of Energy (DOE) requirements.

ROOF JACKS	
12" Non-Adjustable & Air Inlet	AP12032E
15-32" Adjustable & Air Inlet	AP12032B
30-60" Adjustable & Air Inlet	AP12032C
48-95" Adjustable & Air Inlet	AP12032D
AIR INLET	
6" Non-Adjustable	AP12019B
11-22" Adjustable	AP12017B
EXTENSION PIPE KIT	
Roof Jack Extension Pipe Kit	AP12021

Roof jack and air inlet must be ordered separately with 30 and 40-gallon direct vent models and must be in accordance with instructions furnished with the heater. No other roof jack or air inlet assemblies are approved for installation with this heater. Clamps and secure strapping are packed in water heater carton.

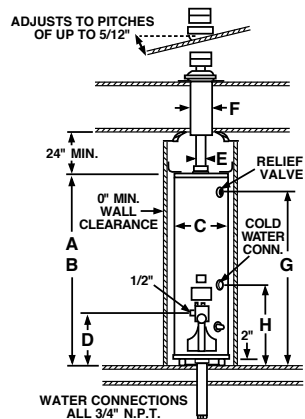

Professional Classic® Direct Vent Co-Axial for Manufactured Housing

Efficiency

- .63 - .65 UEF

Performance

- FHR: 65 gallons for 50-gallon model and 63 gallons for 40-gallon model
- Recovery: 30.3 to 36.4 GPH at a 90° F rise, depending on model

Flexibility

- Field convertible controls and burner assembly for natural gas or LP operation included
- Roof jack flange adjustment range available up to 34° (8 - 12)
- New smaller foot print – no external air tube
- Can be installed anywhere in the home
- 3/4" hot and cold top connections
- Easily fits into a standard drain pan

Altitude Certification

- All models certified up to 10,000 feet above sea level

Low Emissions

- Eco-friendly burner, low NOx design
- Meets 40 ng/J NOx requirements

Longer Life

- Premium grade anode rod provides long-lasting tank protection

Self Cleaning

- EverKleen® patented system fights sediment build-up

Plus...

- Certified for manufactured (HUD) and modular construction
- Enhanced-flow brass drain valve
- Factory installed temperature and pressure relief valve – side location
- Low lead compliant
- Piezo ignition – easy light pilot, no matches required

Warranty

- 6-Year limited tank and parts warranty*

*See Residential Warranty Certificate for complete information

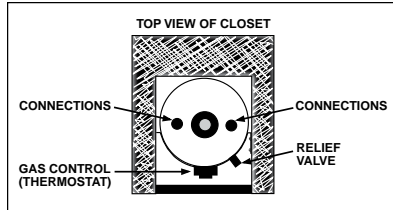

Units meet or exceed ANSI requirements and have been tested according to D.O.E. procedures. Units meet or exceed the energy efficiency requirements of NAECA, ASHRAE standard 90, ICC Code and all state energy efficiency performance criteria.



DESCRIPTION				FEATURES						ROUGHING IN DIMENSIONS (SHOWN IN INCHES)					ENERGY INFO.
TYPE	NOMINAL GALLON CAPACITY	RATED GALLON CAPACITY	MODEL NUMBER	GAS INPUT IN THOUS. BTU/H		RECOVERY IN G.P.H. 90° F RISE		UEF FIRST HR. DEL. G.P.H.		DIAM. A	TANK HEIGHT B	VENT SIZE C	WATER CONN. SIZE	SHIP WT. (LBS)	UNIFORM ENERGY FACTOR (UEF)
				NAT.	LP	NAT.	LP	NAT.	LP						
Tall	40	38	PROG40-36N RH62 MH DVX	36	30	36.4	30.3	63	63	19-3/4	60-1/2	5	3/4	155	0.60
Tall	50	48	PROG50-36N RH60 MH DVX	36	32	36.4	32.3	65	65	21-3/4	59-5/8	5	3/4	165	0.58

Uniform Energy Factor and rated gallon capacity based on Department of Energy (DOE) requirements.

Co-Axial Roof Jack Sizing Table

34° MAX. (8 - 12 PITCH) ROOF JACK KIT PART NO.	ROOF JACK ADJUSTMENT RANGE (SEE X)
AP14363A	24 - 37"
AP14363B	33 - 68"
AP14363C	45 - 97"
AP14363D	60 - 130"
AP14363E	72 - 160"

NOTE: 42° Max. adjustment roof jacks available. Roof Jacks must be ordered separately with this direct vent water heater and installed in accordance with the instructions furnished with the heater. No other roof jack or vertical vent kit is approved for installation with this heater.

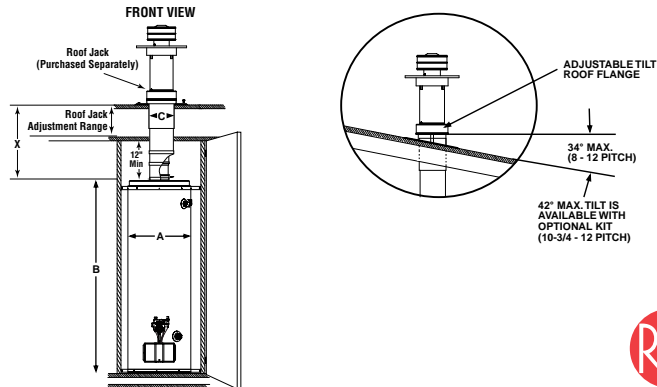

Prestige® Condensing Tankless with Built-In Recirculation

Efficiency

- .94 UEF with dual stainless steel condensing heat exchangers

Easy Installation and Service

- **Vent with PVC up to 100' (3") and 50' (2")**
- **Built-in Recirculation Pump** reduces water waste
- 1/2" Gas line compatibility up to 24 ft.¹
- **High-Altitude Capability** – up to 10,000 ft. elevation above sea level
- **Common Vent Two Units** – Fewer wall penetrations, easier to install and more flexible option
- **Compatible with Room Air Intake** – More install options and faster to install (single units only, not common vented)

Performance

- Instant Hot water at the tap²
- **Max GPM of 11** (on 199K BTU models)
- **Auto-Learn Programming** – Schedules recirculation based on your hot water needs your needs
- **Low Flow Activation** – Minimum flow and minimum activation flow rate of .50 GPM

Environmentally Friendly

- **Low Emissions** – Ultra low NOx burner meets SCAQMD rule 1146.2 requirements

Recirculation Pump Specifications

- Timer-based recirculation pump with option for on-demand accessory wall switch
- Max. Pipe Lengths:
 - 3/4" copper pipe – 500 ft. total
 - 1/2" copper pipe – 200 ft. total

Safety

- Flame Sensor, Overheat Cut Off Limit Switch, Gas Leak Detector Sensor, Water Leak Detector Sensor Exhaust Temperature Sensor, Water Temperature Sensor
- Maximum Water Temperature is 140° F (for applications requiring up to 185° F, see Rheem Commercial Tankless options)

Warranty

- 12-Year heat exchanger – residential, 5-year heat exchanger – commercial, 5-year parts including built-in recirculation pump and 1-year labor*

*See Warranty Certificate for complete information



ACCESSORIES



Quick Connect Cable –
For 2 unit manifolding
SP20892 (optional)



Crossover Valve –
Converts cold water line
into recirculation return
RTG20285



On-Demand Activation Accessory – Converts timer based pump to on-demand activation, with included wall switch
SP20941 (optional)



3000
PROCLUB
POINTS



¹Based on Rheem testing of 1/2" gas line with gas supply of 7" w.c. up to 24'; Installation conditions vary; Consult the Rheem® Use and Care Manual, the Rheem® Gas Piping Facts brochure (TK-GPF-12), the National Fuel Gas Code (NFPA 54, ANSI Z223.1), and any other local gas codes when installing a Rheem Tankless Water Heater.

²Individual results may vary.

DESCRIPTION				FEATURES					ROUGHING IN DIMENSIONS (SHOWN IN INCHES)						ENERGY INFO.	
MODEL NUMBER	GAS INPUT BTU/H	TYPE	NUMBER OF BATHROOMS*	TEMP. RANGE	MIN. FLOW/ACTIVATION GPM	GPM @ 77° RISE MAX.	GPM @ 45° RISE MAX.	MAX. GPM	CONNECTION		HEIGHT	WIDTH	DEPTH	VENT DIAM.	SHIP WEIGHT (LBS.)	UNIFORM ENERGY FACTOR (UEF)
									WATER	GAS						
★ RTGH-RH11DVLN	18,000-199,000	Indoor DV** w/ Recirc Pump	4	100° to 140° F	0.50/0.50	5.0	8.5	11.0	3/4	3/4	28.7	17.3	14.8	2" or 3" PVC 2-Pipe	85	0.94
★ RTGH-RH10DVLN	18,000-180,000	Indoor DV** w/ Recirc Pump	3-4	100° to 140° F	0.50/0.50	4.5	7.7	9.9	3/4	3/4	28.7	17.3	14.8	2" or 3" PVC 2-Pipe	85	0.94

*Based on simultaneous showers using 2.5 GPM flow rate pre-mixed with cold water line. Flow rates vary depending on temperature of incoming cold water and water heater set temperature. Refer to flow rate curves for accurate sizing.

**Can convert to outdoor model with optional Outdoor Conversion Kit (RTG20315).

Uniform Energy Factor based on Department of Energy (D.O.E.) requirements. All models are available in Natural Gas and Propane (LP). For Propane replace the N with P when ordering. SCAQMD 1146.2 compliant.

★ **ENERGY STAR® compliant model.**



Prestige® High Efficiency Condensing Tankless

Efficiency

- Up to .93 UEF with stainless steel condensing heat exchanger

Easy Installation and Service

- **NEW! 2" venting connections**
- **NEW! Vent up to 150 ft with 3" PVC and 60 ft with 2" PVC**
- Built-in condensate neutralizer
- 1/2" Gas line compatibility up to 24 ft.¹
- **Exclusive! Maintenance Notice Setting** – Alerts homeowner, after 500 hours of use, to call for service (optional)
- Self-diagnostic system for easy installation and service
- High-altitude capability – up to 8,400 ft. elevation above sea level²
- Digital remote control **now pre-wired!** 10 ft. of thermostat wire included – shows temperature setting and service codes
- Requires 120V power supply

Performance

- **Industry Leading! Low Flow Activation** – Minimum flow rate of .26 GPM and minimum activation flow rate of .40 GPM ensures hot water even in low demand situations
- **Recirculation Pump Kit-Ready** – Providing faster

hot water at the tap and savings of up to 12,000 gallons water/year³

- **Exclusive! Hot Start Programming** – Minimizes cold water bursts by staying in ready-fire state for back-to-back hot water needs

Technology

- **EcoNet® Enabled** – all Tankless products from 2010 to present can connect to EcoNet mobile app via Tankless EcoNet Accessory Kit (REWRA630TWH)
- For higher demand applications, easily link multiple tankless units to operate as one system:
 - 2 Units: EZ Link cable
 - Up to 6 units: MIC-6 Control Board
 - Up to 20 units: MIC-185 plus MICS-180 manifold control assembly

Environmentally Friendly

- **Low Emissions** – Ultra low NOx burner meets SCAQMD rule 1146.2 requirements
- **Exclusive! Water Savings Setting** – Save up to 1,100 gallons water/year⁴ by reducing flow at the tap until set temperature is achieved (optional)

Safety

- **Exclusive! Overheat film wrap** – prevents dangerous temperatures and provides industry best side-to-side clearance of 1/2 inch
- **Industry Best!** Freeze protection to -30°F

- Maximum Water Temperature is 140° F (for applications requiring up to 185° F, see Rheem Commercial Tankless options)

Warranty

- 12-Year heat exchanger – residential, 5-year heat exchanger – commercial, 5-year parts and 1-year labor*

*See Warranty Certificate for complete information



EcoNet Included models have smart home features:

- Leak Detection & Auto Shut Off (indoor models only)
- Mobile service alerts
- Gas & water usage reports

¹ Based on Rheem testing of 1/2" gas line with gas supply of 7" w.c. up to 24'; installation conditions vary; Consult the Rheem® Use and Care Manual, the Rheem® Gas Piping Facts brochure (TK-GPF-12), the National Fuel Gas Code (NFPA 54, ANSI Z223.1), and any other local gas codes when installing a Rheem Tankless Water Heater.

² Contact customer service for exact altitude rating for each model.

³ Pump kit designed for single unit applications only.

⁴ Savings based on DOE test procedures.



LEED Points = 2

Indoor Direct Vent



3000 PROCLUB POINTS



Outdoor

DESCRIPTION				FEATURES					ROUGHING IN DIMENSIONS (SHOWN IN INCHES)						ENERGY INFO.	
MODEL NUMBER	GAS INPUT BTU/h	TYPE	NUMBER OF BATHROOMS*	TEMP. RANGE	MIN. FLOW/ACTIVATION GPM	GPM @ 67° RISE MAX.	GPM @ 45° RISE MAX.	MAX. GPM	CONNECTION		HEIGHT	WIDTH	DEPTH	VENT DIAM.	SHIP WEIGHT (LBS.)	UNIFORM ENERGY FACTOR (UEF)
									WATER	GAS						
★ RTGH-95DVLN-2	11,000-199,900	Indoor Direct Vent	4	85° to 140° F	0.26/0.40	5.7	8.5	9.5	3/4	3/4	27-1/2	18-1/2	9-3/4	2" or 3" PVC 2-Pipe	82	0.93
★ RTGH-95DVELN-2 (EcoNet® Included)	11,000-199,900	Indoor Direct Vent	4	85° to 140° F	0.26/0.40	5.7	8.5	9.5	3/4	3/4	27-1/2	18-1/2	9-3/4	2" or 3" PVC 2-Pipe	82	0.93
★ RTGH-95XLN-2	11,000-199,900	Outdoor	4	85° to 140° F	0.26/0.40	5.6	8.5	9.5	3/4	3/4	27-1/2	18-1/2	9-3/4	N/A	82	0.93
★ RTGH-95XELN-2 (EcoNet® Included)	11,000-199,900	Outdoor	4	85° to 140° F	0.26/0.40	5.6	8.5	9.5	3/4	3/4	27-1/2	18-1/2	9-3/4	N/A	82	0.93
★ RTGH-90DVLN-2	11,000-180,000	Indoor Direct Vent	3 - 4	85° to 140° F	0.26/0.40	5.2	7.7	9.0	3/4	3/4	27-1/2	18-1/2	9-3/4	2" or 3" PVC 2-Pipe	82	0.93
★ RTGH-90XLN-2	11,000-180,000	Outdoor	3 - 4	85° to 140° F	0.26/0.40	5.2	7.7	9.0	3/4	3/4	27-1/2	18-1/2	9-3/4	N/A	82	0.93
★ RTGH-84DVLN-2	11,000-157,000	Indoor Direct Vent	3	85° to 140° F	0.26/0.40	4.6	6.7	8.4	3/4	3/4	27-1/2	18-1/2	9-3/4	2" or 3" PVC 2-Pipe	82	0.93
★ RTGH-84XLN-2	11,000-157,000	Outdoor	3	85° to 140° F	0.26/0.40	4.5	6.7	8.4	3/4	3/4	27-1/2	18-1/2	9-3/4	N/A	82	0.93
★ RTGH-68DVLN-2	11,000-120,000	Indoor Direct Vent	2.5	85° to 140° F	0.26/0.40	3.4	5.1	6.8	3/4	3/4	27-1/2	18-1/2	9-3/4	2" or 3" PVC 2-Pipe	82	0.91
★ RTGH-68XLN-2	11,000-120,000	Outdoor	2.5	85° to 140° F	0.26/0.40	3.4	5.1	6.8	3/4	3/4	27-1/2	18-1/2	9-3/4	N/A	82	0.91

*Based on simultaneous showers using 2.5 GPM flow rate pre-mixed with cold water line. Flow rates vary depending on temperature of incoming cold water and water heater set temperature. Refer to flow rate curves for accurate sizing. Uniform Energy Factor and Energy Factor based on Department of Energy (D.O.E.) requirements. All models are available in Natural Gas and Propane (LP). For Propane replace the N with P when ordering. SCAQMD 1146.2 compliant.

★ **ENERGY STAR® compliant model.**

Factory set maximum temperature is 120° F. See Use and Care Manual for setting. Consult factory for information on sizing the application.

Add a "C" to the model number when ordering Canadian models. Outdoor models are only for seasonal use in Canada. Please contact Rheem Canada Ltd. for details.

Vent Termination Kits are required for Direct Vent models. Contact your distributor for details.

Proper gas pressure must be ensured to supply tankless gas water heaters – up to 199,900 BTU/h for RTGH-95 models, up to 180,000 BTU/h for RTGH-90 models, up to 157,000 BTU/h for RTGH-84 models, up to 120,000 BTU/h for RTGH-68 models. (Consult your gas supplier)



Mid-Efficiency Tankless

Efficiency

- .81 - .82 UEF with all-copper heat exchanger

Easy Installation and Service

- 1/2" Gas line compatibility up to 24 ft.¹
- **Exclusive! Maintenance Notice Setting** – Alerts homeowner, after 500 hours of use, to call for service (optional)
- Connects to Metal Fab. Inc., 3"/5" concentric venting without an adapter
- High-altitude capability – up to 8,400 ft. elevation above sea level²
- Digital remote control shows temperature setting and service codes
- Requires 120V power supply

Performance

- **Low Flow Activation** – Minimum flow rate of .26 GPM and activation flow rate of .40 GPM ensures hot water in low demand situations
- **Exclusive! Hot Start Programming** – Minimizes cold water bursts by staying in ready-fire state for back-to-back hot water needs

Technology

- **WiFi Enabled** – Models from 2010 to present can connect to EcoNet mobile app via Tankless EcoNet Accessory Kit (REWRA630TWH)

- For higher demand applications, accessories available to link multiple units in a load-sharing system

Environmentally Friendly

- **Low Emissions** – Ultra low NOx burner meets SCAQMD rule 1146.2 requirements
- **Exclusive! Water Savings Setting** – upon activation, this setting can save up to 1,100 gallons water/year³ by reducing flow at the tap until set temperature is achieved (optional)

Safety

- **Exclusive! Guardian Overheat Film Wrap** – prevents dangerous temperatures and provides industry best side-to-side clearance of 1/2 inch
- **Industry Best!** Freeze protection to -30°F
- Maximum water temperature is 140°F. For higher temperature applications, upgrade kits are available

Warranty

- 12-Year heat exchanger – residential, 5-year heat exchanger – commercial, 5-year parts and 1-year labor*

*See Warranty Certificate for complete information



Included models have smart home features:

- Leak Detection & Auto Shut Off (indoor only)
- Mobile service alerts
- Gas & water usage reports

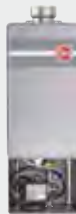

Rheem Mid-Efficiency Tankless with Built-In Recirculation

Recirculation saves up to **12,000 GALLONS** water/year⁴

Same specifications as standard Mid-Efficiency models with added water savings and faster hot water.

1500 PROCLUB POINTS

Indoor Direct Vent



Outdoor

¹Based on Rheem testing of 1/2" gas line with gas supply of 7" w.c. up to 24'; Installation conditions vary; Consult the Rheem® Use and Care Manual, the Rheem® Gas Piping Facts brochure (TK-GPF-12), the National Fuel Gas Code (NFPA 54, ANSI Z223.1), and any other local gas codes when installing a Rheem Tankless Water Heater.

²Contact customer service for exact altitude rating for each model.

³Savings based on DOE test procedures.

⁴Savings per News Bulletin released by the United States Department of Energy / Oak Ridge National Laboratory, November 2002 on study on water and energy savings in residential homes using Hot Water Recirculating System.

DESCRIPTION			FEATURES						ROUGHING IN DIMENSIONS (SHOWN IN INCHES)						ENERGY INFO.	
MODEL NUMBER	GAS INPUT BTU/h	TYPE	NUMBER OF BATHROOMS*	TEMP. RANGE	MIN. FLOW/ACTIVATION GPM	GPM @ 67° RISE MAX.	GPM @ 45° RISE MAX.	MAX. GPM	CONNECTION		HEIGHT	WIDTH	DEPTH	VENT DIAM.	SHIP WEIGHT (LBS.)	UNIFORM ENERGY FACTOR (UEF)
									WATER	GAS						
RTG-RC95DVLN-1 (Recirculation Pump Included)	11,000-199,900	Indoor DV w/ Recirc Pump	3-4	85° to 140° F	0.26/0.40	5.0	7.4	9.5	3/4	3/4	36-3/4	13-7/8	9-7/8	3 by 5 CONCENTRIC	80	0.82
RTG-95DVLN-1	11,000-199,900	Indoor Direct Vent	3-4	85° to 140° F	0.26/0.40	5.0	7.4	9.5	3/4	3/4	25-5/8	13-7/8	9-7/8	3 by 5 CONCENTRIC	54	0.82
RTG-95DVELN-1 (EcoNet® Included)	11,000-199,900	Indoor Direct Vent	3-4	85° to 140° F	0.26/0.40	5.0	7.4	9.5	3/4	3/4	25-5/8	13-7/8	9-7/8	3 by 5 CONCENTRIC	54	0.82
RTG-95XLN-1	11,000-199,900	Outdoor	3-4	85° to 140° F	0.26/0.40	4.9	7.4	9.5	3/4	3/4	23-5/8	13-7/8	8-7/8	N/A	54	0.81
RTG-95XELN-1 (EcoNet® Included)	11,000-199,900	Outdoor	3-4	85° to 140° F	0.26/0.40	4.9	7.4	9.5	3/4	3/4	23-5/8	13-7/8	8-7/8	N/A	54	0.81
RTG-84DVLN-1	11,000-180,000	Indoor Direct Vent	3	85° to 140° F	0.26/0.40	4.5	6.7	8.4	3/4	3/4	25-5/8	13-7/8	9-7/8	3 by 5 CONCENTRIC	54	0.82
RTG-84XLN-1	11,000-180,000	Outdoor	3	85° to 140° F	0.26/0.40	4.5	6.7	8.4	3/4	3/4	23-5/8	13-7/8	8-7/8	N/A	54	0.81
RTG-70DVLN-1	11,000-160,000	Indoor Direct Vent	2-3	85° to 140° F	0.26/0.40	4.1	6.0	7.0	3/4	3/4	25-5/8	13-7/8	9-7/8	3 by 5 CONCENTRIC	54	0.82
RTG-70XLN-1	11,000-160,000	Outdoor	2-3	85° to 140° F	0.26/0.40	4.1	6.0	7.0	3/4	3/4	23-5/8	13-7/8	8-7/8	N/A	54	0.81

*Based on simultaneous showers using 2.5 gallons per minute. Flow rates vary depending on temperature of cold water supply.

Uniform Energy Factor and Energy Factor based on Department of Energy (D.O.E.) requirements.

All models are available in Natural Gas and Propane (LP). For Propane replace the N with P when ordering.

SCAQMD 1146.2 compliant. Factory set maximum temperature is 120° F. See Use and Care Manual for setting. Consult factory for information on sizing the application.

Add a "C" to the model number when ordering Canadian models. Outdoor models are only for seasonal use in Canada. Please contact Rheem Canada Ltd. for details.

Vent Termination Kits are required for Direct Vent models. Contact your distributor for details.

Proper gas pressure must be ensured to supply tankless gas water heaters – up to 199,900 BTU/h for RTG-95 models, up to 180,000 BTU/h for RTG-84 models and up to 160,000 BTU/h for RTG-70 models. (Consult your gas supplier)



Prestige® Combination Boiler

Key Features

- **Space Heating and Hot Water** — Efficient heating combined with continuous hot water all from one unit for space and cost savings
- **Perfect for Replacing a Boiler** — Compatible with any hydronic heat emitting devices including air handlers
- **Saves Space** — A single, compact combi boiler can replace a boiler AND tank water heater
- **Built-in Auto-Feeder** — Maintains hydronic loop pressure automatically between 12-30 psi
- **Outdoor Reset Sensor** — Tracks outdoor temperatures and overrides the heating set point as-needed to keep the home comfortable when weather changes
- **Auto Boost Feature**¹ — If the thermostat set point has not been achieved in a reasonable time, the unit will auto boost the hydronic loop to reach the desired temperature more quickly
- **Max Vent Lengths: 100' @ 3", 50' @ 2"**² — Means more flexible and versatile installation options
- **Vent with Room Air**³ — Save time and money on installation
- **4.5 GPM at 77°F Rise** — for 199,000 BTU model

Warranty

- 10-Year heat exchanger – residential, 5-year parts and 1-year labor*

*See Warranty Certificate for complete information

Accessories



CONDENSATE NEUTRALIZER

For safe disposal of condensate⁴
SP1215
(Optional)



PRIMARY MANIFOLD ACCESSORY

Make installations easier with pre-assembled manifold kit
RTG20318
(Optional)



SERVICE VALVES

Enable easy isolation of the pump for annual maintenance
RTG20220AB
(Sold Separately)



VENTING TERMINATION KITS

Allow for an easy installation with concentric or horizontal venting kits
SP20245 – 3" Concentric
SP20286 – 3" Low-Profile



95% AFUE

qualifies for top rebates across the US⁵



¹ Auto Boost Feature requires installation of outdoor reset sensor.

² Up to 50' @ 2" and 100' @ 3"; Maximum equivalent venting lengths: see Installation Instructions for additional details.

³ Follow the National Fuel Gas Code (ANSI Z223.1 / NFPA 54)

⁴ Check your local plumbing codes.

⁵ See local offers for details.

DESCRIPTION					FEATURES						ROUGHING IN DIMENSIONS (SHOWN IN INCHES)						ENERGY INFO.	
MODEL NUMBER	DHW GAS INPUT BTU/H	HEATING MODE GAS INPUT RATE	TYPE	NUMBER OF BATHROOMS*	DHW TEMP. RANGE	HEATING MODE TEMP. RANGE	MIN. FLOW/ACTIVATION GPM	GPM @ 77° RISE MAX.	GPM @ 45° RISE MAX.	MAX. GPM	CONNECTION		HEIGHT	WIDTH	DEPTH	VENT DIAM.	SHIP WEIGHT (LBS.)	AFUE
											WATER	GAS						
★ RCBH199-DVL	18,000-199,000	8,000 - 120,000	Indoor Direct Vent	4	90° to 140° F	100° to 180° F	0.40/0.50	4.5	7.7	9.9	3/4	3/4	28.7	17.3	14.8	2" or 3" PVC 2-Pipe	90	95%
★ RCBH180-DVL	18,000-180,000	18,000 - 100,000	Indoor Direct Vent	3-4	90° to 140° F	100° to 180° F	0.40/0.50	4.1	7.0	9.0	3/4	3/4	28.7	17.3	14.8	2" or 3" PVC 2-Pipe	90	95%

*Based on simultaneous showers using 2.5 GPM flow rate pre-mixed with cold water line. Flow rates vary depending on temperature of incoming cold water and water heater set temperature.

Refer to flow rate curves for accurate sizing.

All models are available in Natural Gas and Propane (LP). For Propane replace the N with P when ordering.

SCAQMD 1146.2 compliant.

★ **ENERGY STAR®** compliant model.



Professional Prestige® Hybrid

Efficiency

- High 3.55 - 3.70 UEF reduces operating cost
- ENERGY STAR® rated

Performance

- Delivers hot water faster than most standard electric water heaters – 67 gallons first-hour delivery for 50-gallon model, 75 gallons FHD for 65-gallon model and 89 gallons FHD for 80-gallon model (30 amp models)
- Ambient operating range: 37-145° F is widest in class, offering more days of HP operation annually; designed to meet Northern Climate Spec (Tier 3)

Easy Installation

- Easy access side connections
- Quick access to electrical junction box
- Easily replaces a standard electric water heater

Integration

- LCD Screen with built-in water sensor alert with audible alarm
- Integrated EcoNet® WiFi-connected† technology and free mobile app gives users control over water systems, allowing for



customizable temperature, vacation settings, energy savings and system monitoring at home or away. Visit Rheem.com/hybridsolutions

- Water sensor detects water outside of the unit and sends an alert via the free Rheem EcoNet® mobile app to the homeowner

Operation Modes

- Energy Saver
- Heat Pump
- High Demand
- Electric
- Vacation: 2-28 days (or placed on hold indefinitely)

Plus...

- Premium grade anode rod with resistor extends the life of the tank
- 3/4" NPT water inlet and outlet; 3/4" condensate drain connections
- Incoloy stainless steel resistor elements
- Dry-fire protection
- Easy access, top mounted washable air filter
- 2" Non-CFC foam insulation
- Enhanced flow brass drain valve
- Temperature and pressure relief valve installed
- Low lead compliant

Accessories

- Earthquake Kit part number SP20882, sold separately
- Vibration Isolation Kit part number SP20883, sold separately

Warranty

- 10-Year limited tank and parts warranty*

*See Residential Warranty Certificate for complete information

† WiFi broadband internet connection required.

Units meet or exceed ANSI requirements and have been tested according to D.O.E. procedures. Units meet or exceed the energy efficiency requirements of NAECA, ASHRAE standard 90, ICC Code and all state energy efficiency performance criteria.



DESCRIPTION					ENERGY INFO		FEATURES				TANK DIMENSIONS (SEE SPACE REQUIREMENTS IN DIAGRAMS BELOW)					
NOMINAL GALLON CAPACITY	RATED GALLON CAPACITY	MODEL NUMBER	MODEL VARIANT	ELECTRIC BREAKER SIZE	UNIFORM ENERGY FACTOR (UEF)	ESTIMATED YEARLY ENERGY COST	COMPRESSOR BTU/H	SOUND LEVEL (dBA)	UEF FIRST HR. RATING G.P.H.	RECOVERY IN G.P.H 90° F RISE	HEIGHT A	DIAM. B	HT. TO COLD INLET & DRAIN VALVE	HT. TO HOT OUTLET & T&P	UNIT WT. (LBS)	APPROX. SHIP WT. (LBS.)
50	45	★PROPH50 T2 RH350 DCB	692104	30	3.55	\$110	4200	49	67	29	61"	22-1/4"	3-5/8"	39-5/8"	178	218
50	45	★PROPH50 T2 RH350 D	694030	15	3.55	\$110	4200	49	53	16	61"	22-1/4"	3-5/8"	39-5/8"	178	218
65	59	★ PROPH65 T2 RH350 DCB	692111	30	3.70	\$161	4200	49	75	29	64"	24-1/4"	3-7/8"	42-3/8"	225	262
65	59	★ PROPH65 T2 RH350 D15	694146	15	3.55	\$110	4200	49	53	16	64"	24-1/4"	3-7/8"	42-3/8"	225	262
80	72	★ PROPH80 T2 RH350 DCB	692128	30	3.70	\$161	4200	49	89	29	74"	24-1/4"	3-7/8"	52-3/8"	244	281
80	72	★ PROPH80 T2 RH350 D15	694054	15	3.55	\$110	4200	49	67	16	74"	24-1/4"	3-7/8"	52-3/8"	244	281

Estimated energy cost based on a national average electricity cost of \$0.12 /kWh. Uniform Energy Factor and rated gallon capacity based on Department of Energy (DOE) requirements.

All units have integrated WiFi control board.

★ **ENERGY STAR® compliant model.**

DESCRIPTION		DIMENSIONS (SHOWN IN INCHES)											
NOMINAL GALLON CAPACITY	MODEL NUMBER	A	B	C	D	E	F	G	H	I	J	K	L
50	PROPH50	61	22-1/4	47	3-5/8	39-5/8	28	24	36	50	27	77	73
65	PROPH65	64	24-1/4	49	3-7/8	42-3/8	30	26	38	52	29	80	76
80	PROPH80	74	24-1/4	59	3-7/8	52-3/8	30	26	38	52	29	90	86

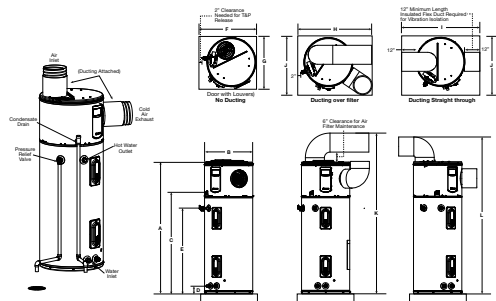

Professional Prestige®

Efficiency

- .93 UEF
- Isolated tank design reduces conductive heat loss
- Dual 5500 watt stainless steel heating elements

Performance

- FHR: 56 - 63 gallons based on gallon capacity
- Recovery: 25 GPH at a 90° F rise

Super Sentinel Diagnostic System

- Simple easy to read diagnostics
- Controls multiple operating modes
- Digital thermostat setting
- Built-in water sensor alert with audible alarm and service notifications



- EcoNet® WiFi-connected† technology and free mobile app gives users control over water systems, allowing for customizable temperature, vacation settings, energy savings and system monitoring at home or away. Visit Rheem.com/EcoNetConnect



- Water sensor detects water outside of the unit and sends an alert via the free EcoNet® mobile app to the homeowner
- EcoNet® WiFi Kit included

Features

- High performance and lower operating cost
- Compliant with many electric utility incentive programs
- Premium grade anode rod provides long-lasting tank protection
- Electric junction box located above heating elements for easy installation
- Over-temperature protector cuts off power in excess temperature situations

Plus...

- Rheemglas® tank lining resists corrosion and prolongs tank life
- EverKleen® self cleaning device fights harmful sediment build-up with a high-velocity spiraling water stream – helps operating efficiency by saving energy, money and improving tank life
- Enhanced-flow brass drain valve
- Temperature and pressure relief valve included
- Low lead compliant

Warranty

- 12-Year limited tank and parts warranty*

*See Residential Warranty Certificate for complete information

† WiFi broadband internet connection required

Units meet or exceed ANSI requirements and have been tested according to D.O.E. procedures. Units meet or exceed the energy efficiency requirements of NAECA, ASHRAE standard 90, ICC Code and all state energy efficiency performance criteria.



DESCRIPTION				FEATURES		ROUGHING IN DIMENSIONS (SHOWN IN INCHES)				ENERGY INFO.
T Y P E	NOMINAL GALLON CAPACITY	RATED GALLON CAPACITY	MODEL NUMBER	UEF FIRST HOUR RATING G.P.H.	RECOVERY IN G.P.H. 90° F RISE	TANK HEIGHT A	HEIGHT TO WATER CONN. B	DIAMETER C	APPROX. SHIP WT. (LBS.)	UNIFORM ENERGY FACTOR (UEF)
Tall	40	36	PROPE40 T2 RH95 EC2	56	25	60-3/4	63-5/8	18-1/4	105	0.93
Tall	50	45	PROPE50 T2 RH95 EC2	63	25	58-5/8	61-5/8	20-1/4	121	0.93

Uniform Energy Factor and rated gallon capacity based on Department of Energy (DOE) requirements.

Super Sentinel not available on single element models, available on dual element models only. Super Sentinel not available in excess of 5 kW on 208 V models.

- Heaters furnished with standard 240 volt AC, single phase non-simultaneous wiring, and 5500 watt upper and lower heating elements.

**Recovery = wattage/2.42 x temp. rise °F.
 Example: $\frac{5500W}{2.42 \times 90^\circ} = 25 \text{ GPH}$

**Recovery calculations used are based on 5500 watt elements used in non-simultaneous operation.

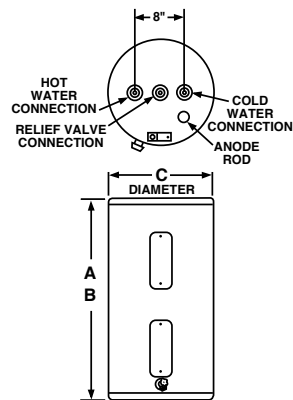

WATER CONNECTIONS ALL 3/4" N.P.T.



Professional Classic Plus®

Efficiency

- .90 - .93 UEF
- Isolated tank design reduces conductive heat loss
- Resisted stainless steel upper and lower heating elements to prolong anode rod and tank life

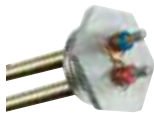

Performance

- FHR: 45 - 72 gallons, based on gallon capacity
- Recovery: 21 GPH at a 90° F rise

System Sentinel

- Exclusive diagnostic system with glowing LEDs that verify heating element operation. LEDs pin point the exact location of functioning or non-functioning heating elements

Features

- High performance and lower operating cost
- Compliant with many electric utility incentive programs
- Premium grade anode rod provides long-lasting tank protection
- Electric junction box located above heating elements for easy installation
- Over-temperature protector cuts off power in excess temperature situations
- Automatic thermostat keeps water at desired temperature

Plus...

- Rheemglas® tank lining resists corrosion and prolongs tank life
- EverKleen® self cleaning device fights harmful sediment build-up with a high-velocity spiraling water stream – helps operating efficiency by saving energy, money and improving tank life
- Enhanced-flow brass drain valve
- Temperature and pressure relief valve included
- Low lead compliant

Warranty

- 8-Year limited tank and parts warranty*
- With ProtectionPlus® the 8-year limited tank warranty becomes 12-year

*See Residential Warranty Certificate for complete information

Units meet or exceed ANSI requirements and have been tested according to D.O.E. procedures. Units meet or exceed the energy efficiency requirements of NAECA, ASHRAE standard 90, ICC Code and all state energy efficiency performance criteria.



DESCRIPTION				FEATURES		ROUGHING IN DIMENSIONS (SHOWN IN INCHES)				ENERGY INFO.
T Y P E	NOMINAL GALLON CAPACITY	RATED GALLON CAPACITY	MODEL NUMBER	UEF FIRST HOUR RATING G.P.H.	RECOVERY IN G.P.H. 90° F RISE	TANK HEIGHT A	HEIGHT TO WATER CONN. B	DIAMETER C	APPROX. SHIP WT. (LBS.)	UNIFORM ENERGY FACTOR (UEF)
Tall	30	27	PRO+E30 T2 RH95 EC1	46	21	47-1/2	50-3/8	19-1/4	92	0.92
Tall	40	36	PRO+E40 T2 RH95 EC1	55	21	60-3/4	63-5/8	19-1/4	109	0.93
Tall	50	45	PRO+E50 T2 RH95 EC1	63	21	58-5/8	61-5/8	20-3/8	121	0.93
Tall	55	55	PRO+E55 T2 RH94 EC1	72	21	57	59-3/4	22-1/4	128	0.92
Med.	30	27	PRO+E30 M2 RH95 EC1	45	21	37-1/2	40-1/2	20-1/4	92	0.90
Med.	40	36	PRO+E40 M2 RH95 EC1	55	21	48-1/4	50-1/2	20-1/4	106	0.93
Med.	50	45	PRO+E50 M2 RH95 EC1	62	21	48	50-1/2	23	132	0.93

Uniform Energy Factor and rated gallon capacity based on Department of Energy (DOE) requirements.

• Heaters furnished with standard 240 volt AC, single phase non-simultaneous wiring, and 4500 watt upper and lower heating elements.

• **If heating elements of different wattages than those shown are demanded by zone requirements, they must be specifically requested.**

• Special Wiring Options – A limited number of special wiring options are available. Consult factory for price and availability.

• All models equipped with heat traps.

**Recovery = wattage/2.42 x temp. rise °F.
 Example: $\frac{4500W}{2.42 \times 90^\circ} = 21 \text{ GPH}$

**Recovery calculations used are based on 4500 watt elements used in non-simultaneous operation.

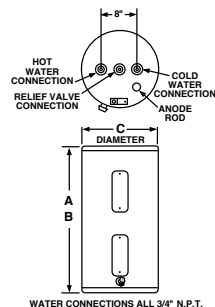

Professional Classic®

Efficiency

- .90 - .93 UEF
- Isolated tank design reduces conductive heat loss
- Resistored copper upper element and resistored Lifeguard™ stainless steel lower element to prolong anode rod and tank life



Performance

- FHR: 45 - 67 gallons, based on gallon capacity
- Recovery: 21 GPH at a 90° F rise

System Sentinel

(Available on selected models)

- Exclusive diagnostic system with glowing LEDs that verify heating element operation. LEDs pin point the exact location of functioning or non-functioning heating elements

Longer Life

- Premium grade anode rod provides long-lasting tank protection

Features

- Electric junction box located above heating elements for easy installation
- Over-temperature protector cuts off power in excess temperature situations
- Automatic thermostat keeps water at desired temperature

Plus...

- Rheemglas® tank lining resists corrosion and prolongs tank life
- EverKleen® self cleaning device fights harmful sediment build-up with a high-velocity spiraling water stream – helps operating efficiency by saving energy, money and improving tank life
- Enhanced-flow brass drain valve
- Temperature and pressure relief valve included
- HUD certified for manufactured housing and modular construction
- Low lead compliant

Warranty

- 6-Year limited tank and parts warranty*
- With ProtectionPlus® the 6-year limited tank warranty becomes 10-year

*See Residential Warranty Certificate for complete information

Units meet or exceed ANSI requirements and have been tested according to D.O.E. procedures. Units meet or exceed the energy efficiency requirements of NAECA, ASHRAE standard 90, ICC Code and all state energy efficiency performance criteria.



Ask about LEED Points

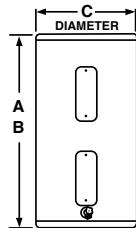
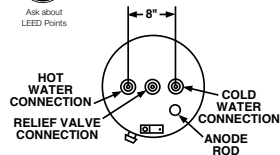

WATER CONNECTIONS ALL 3/4" N.P.T.



DESCRIPTION				FEATURES		ROUGHING IN DIMENSIONS (SHOWN IN INCHES)				ENERGY INFO.
T Y P E	NOMINAL GALLON CAPACITY	RATED GALLON CAPACITY	MODEL NUMBER	UEF FIRST HOUR RATING G.P.H.	RECOVERY IN G.P.H. 90° F RISE	TANK HEIGHT A	HEIGHT TO WATER CONN. B	DIAMETER C	APPROX. SHIP WT. (LBS.)	UNIFORM ENERGY FACTOR (UEF)
Tall	30	27	PROE30 T2 RH95†	46	21	47-1/2	50-3/8	19-1/4	92	0.92
Tall	40	36	PROE40 T2 RH95†	55	21	60-3/4	63-5/8	19-1/4	109	0.93
Tall	50	45	PROE50 T2 RH95†	63	21	58-5/8	61-5/8	20-1/4	121	0.93
Tall	55	55	PROE55 T2 RH94†	72	21	57	59-3/4	22-1/4	128	0.92
Med.	30	27	PROE30 M2 RH95†	45	21	37-1/2	40-1/2	20-1/4	92	0.90
Med.	40	36	PROE40 M2 RH95†	55	21	48-1/4	50-1/2	20-1/4	106	0.93
Med.	50	45	PROE50 M2 RH95†	62	21	48	50-1/2	23	132	0.93
Short	19.9	–	PROE20 S2 RH	–	21	31-1/2	31-1/2	17	62	–
Short	28	25	PROE28 S2 RH95	45	21	30	31-1/8	23	95	0.92
Short	30	27	PROE30 S2 RH95 B**	46	21	30-1/8	32	19-3/4	95	0.92
Short	36	33	PROE36 S2 RH95	46	21	31-1/2	33	24-1/4	118	0.92
Short	38	35	PROE38 S2 RH95 B**	51	21	31-1/2	32-5/8	23	108	0.92
Short	47	43	PROE47 S2 RH95	54	21	32	34	26-1/4	149	0.93

Uniform Energy Factor and rated gallon capacity based on Department of Energy (DOE) requirements.

† **System Sentinel optional. Add EC1 to the end of the model number. System Sentinel not available on single element models, available on dual element models only.**

System Sentinel not available in excess of 5 kW on 208 V models.

** Water heater dimensions prior to installing insulation blanket that is included with water heater

• Heaters furnished with standard 240 volt AC, single phase non-simultaneous wiring, and 4500 watt upper and lower heating elements.

• **If heating elements of different wattages than those shown are demanded by zone requirements, they must be specifically requested.**

• Single element models available on special order (6000W max.). Substitute "1" for "2" in model number.

• Special Wiring Options – A limited number of special wiring options are available. Consult factory for price and availability.

• All models equipped with heat traps.

Recovery calculations used are based on 4500 watt elements used in non-simultaneous operation.

$$\text{Recovery} = \frac{\text{wattage}}{2.42 \times \text{temp. rise } ^\circ\text{F.}}$$

Example: $\frac{4500\text{W}}{2.42 \times 90^\circ} = 21 \text{ GPH}$



Professional *Classic*[®] Point-of-Use

Efficiency

- .90 UEF for 30-gallon model
- Single resistored stainless steel heating element

Features

- High efficiency heating element
- Over-temperature protector cuts off power in excess temperature situations
- Automatic thermostat keeps water at desired temperature
- Wall bracket for easy wall mount installations and corrosion resistant 1/4 turn drain valve included with 2.5 gallon model

Plus...

- Temperature and pressure relief valve
- Exclusive Rheemglas[®] tank lining resists corrosion and prolongs tank life
- Meets or exceeds National Appliance Energy Conservation Act (NAECA) requirements
- These units are U.L. listed and comply with Underwriter's Laboratories Specifications 174
- Enhanced-flow brass drain valve on 2.5-gallon model
- Low lead compliant

Warranty

- 6-Year limited tank and parts warranty*

*See Residential Warranty Certificate for complete information

Units meet or exceed ANSI requirements and have been tested according to D.O.E. procedures. Units meet or exceed the energy efficiency requirements of NAECA, ASHRAE standard 90, ICC Code and all state energy efficiency performance criteria.



2.5-Gallon



6, 10, 15, 19.9
and 30-Gallon

DESCRIPTION				ROUGHING IN DIMENSIONS (SHOWN IN INCHES)						ENERGY INFO.
T Y P E	NOMINAL GALLON CAPACITY	RATED GALLON CAPACITY	MODEL NUMBER	TANK HEIGHT A	HEIGHT TO HOT WATER OUTLET B	DIAMETER C	HEIGHT TO SIDE T&P VALVE D	HEIGHT TO COLD WATER INLET E	APPROX. SHIP WT. (LBS.)	UNIFORM ENERGY FACTOR (UEF)
POU	2.5	–	PROE2 1 RH POU	14	14	9-3/4	–	–	22	–
POU	6	–	PROE6 1 RH POU	15-1/4	12-1/2	15-3/4	11-1/2	4-1/4	36	–
POU	10	–	PROE10 1 RH POU	23	20-1/2	15-3/4	19-1/2	4-1/4	46	–
POU	15	–	PROE15 1 RH POU	24-1/4	22	17-3/4	21	4-1/2	54	–
POU	19.9	–	PROE20 1 RH POU	25-1/4	22-3/4	19-3/4	21-3/4	5	69	–
POU	30	27	PROE30 1 RH95 POU*	31-7/8	23-1/8	22-1/4	23	3	91	0.90

Uniform Energy Factor and rated gallon capacity based on Department of Energy (DOE) requirements.

*For double element, substitute "2" suffix for "1". Not available in 120 volt. Available with 2-wire (single phase) outlet only. (6000 watt max.).

- **2.5 gallon model:** 1/2" N.P.T. inlet and outlet. Relief valve connection 3/4".

Available with 120 or 240 volt AC single phase only, 120v (1440w) 240v (1500w)

Power cord supplied with 120 volt models only.

- **6 through 30 gallon models:** 3/4" N.P.T. outlet, inlet, anode rod. T & P valve connections. Not available with 3 phase wiring.

Water heaters furnished standard with 120 volt AC, 2000 watt single element.

Special wiring options – a limited number of wiring options are available. Consult factory for price and availability.

CONSTRUCTION DETAILS: The cold water enters the tank a few inches from the bottom. Both hot and cold water lines may be connected directly to the water heater without special nipples or tees. The relief valve simply screws into the opening provided.

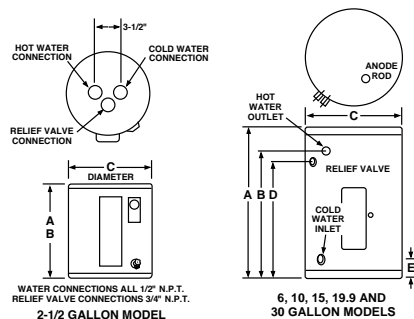

Professional *Classic*® for Manufactured Housing

Efficiency

- .92 - .93 UEF
- Isolated tank design reduces conductive heat loss
- Resistored Lifeguard™ stainless steel lower heating element to prolong anode rod and tank life

Performance

- FHR: Up to 55 gallons, depending on model
- Recovery: 17 GPH for 3500 watts and 21 GPH for 4500 watts at a 90° F rise**

Longer Life

- Premium grade anode rod provides long-lasting tank protection

Features

- High performance and lower operating cost
- Compliant with H.U.D., ASHRAE 90A-80 and NAECA requirements
- Single and double element models available. High efficiency resistored heating element in single element models. Lifeguard™ stainless steel element is the upper element in double element models

- Electric junction box located above heating elements for easy installation
- Over-temperature protector cuts off power in excess temperature situations
- Automatic thermostat keeps water at desired temperature

Plus...

- Certified for manufactured (HUD) and modular construction
- Rheemglas® tank lining resists corrosion and prolongs tank life
- EverKleen® self cleaning device fights harmful sediment build-up with a high-velocity spiraling water stream – helps operating efficiency by saving energy, money and improving tank life
- Enhanced-flow brass drain valve
- Temperature and pressure relief valve included
- Low lead compliant

Warranty

- 6-Year limited tank and parts warranty*

*See Residential Warranty Certificate for complete information

Units meet or exceed ANSI requirements and have been tested according to D.O.E. procedures. Units meet or exceed the energy efficiency requirements of NAECA, ASHRAE standard 90, ICC Code and all state energy efficiency performance criteria.



LEED Point = 1

DESCRIPTION				FEATURES				ROUGHING IN DIMENSIONS (SHOWN IN INCHES)				ENERGY INFO.
TYPE	NOMINAL GALLON CAPACITY	RATED GALLON CAPACITY	MODEL NUMBER	UEF FIRST HOUR RATING G.P.H.		RECOVERY IN G.P.H. 90° F RISE		TANK HEIGHT A	HEIGHT TO WATER CONN. B	DIAMETER C	APPROX. SHIP WT. (LBS.)	UNIFORM ENERGY FACTOR (UEF)
				3500 WATTS	4500 WATTS	3500 WATTS	4500 WATTS					
Tall	19.9	–	PROE20 1 RH MH	–	–	–	–	31-1/2	25-1/2	17-3/4	62	–
Tall	30	27	PROE30 1 RH95 MH†	30	47	17	21	47-3/4	39-1/2	19	92	0.92
Tall	30	27	PROE30 2 RH95 MH†	30	47	17	21	47-3/4	39-1/2	19	92	0.92
Tall	40	36	PROE40 1 RH95 MH†	34	53	17	21	48-1/2	40-1/8	21-1/8	106	0.93
Tall	40	36	PROE40 2 RH95 MH†	34	53	17	21	48-1/2	40-1/8	21-1/8	106	0.93
Tall	50	45	PROE50 1 RH95 MH	42	55	17	21	59	50-5/8	21-1/8	124	0.92
Tall	50	45	PROE50 2 RH95 MH	42	55	17	21	59	50-5/8	21-1/8	124	0.92

Uniform Energy Factor and rated gallon capacity based on Department of Energy (DOE) requirements.

- **If heating elements of different wattages than those shown are demanded by zone requirements, they must be specifically requested.**
- Heaters furnished with standard 240 volt AC, single phase non-simultaneous wiring, and 3500 watt or 4500 watt heating elements. PROE20 1 RH MH furnished with standard 120 volt AC, single phase, 2000 watt heating element.
- Special Wiring Options – A limited number of special wiring options are available. Consult factory for price and availability.

**Recovery = wattage/2.42 x temp. rise °F.
 Example: $\frac{4500W}{2.42 \times 90^\circ} = 21 \text{ GPH}$

**Recovery calculations used are based on 4500 watt elements used in non-simultaneous operation.



UL Listed
 LEED Point = 1

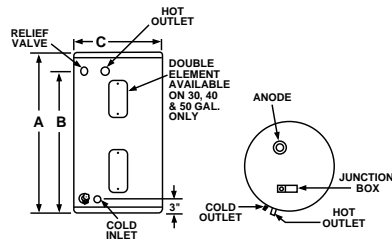

WATER CONNECTIONS ALL 3/4" N.P.T.



Table Top

Table Top Features

- Baked enamel counter top is acid and heat resistant
- Four inch high backsplash protects interior wall from spills and stains
- Recessed base provides comfortable standing area while working
- Channel at rear accommodates piping and permits water heater to fit snugly against back wall
- More hot water at a low operating cost

Efficiency

- .81 UEF
- Well insulated for reduced standby heat loss

Performance

- FHR: 50 gallons
- Recovery: 21 GPH at a 90° F rise

Capacity & Dimensions

- 40 Gallon model: 24 inch diameter: 25 inch depth and 36 inches high

Easy Installation & Service

- Table top surface is easily removed for access to cold and hot water outlets at top of tank, electrical connections and anode rod replacement

Longer Life

- Patented magnesium anode rod with resistor protects the tank from rust

Plus...

- Durable direct immersion resistored heating element
- Full-flow, brass drain valve
- Temperature and pressure relief valve
- Low lead compliant
- Standard replacement parts

Warranty

- 6-Year limited tank and parts warranty*

*See Residential Warranty Certificate for complete information

Units meet or exceed ANSI requirements and have been tested according to D.O.E. procedures. Units meet or exceed the energy efficiency requirements of NAECA, ASHRAE standard 90, ICC Code and all state energy efficiency performance criteria.



DESCRIPTION			FEATURES		ROUGHING IN DIMENSIONS (SHOWN IN INCHES)					ENERGY INFO.
NOMINAL GALLON CAPACITY	RATED GALLON CAPACITY	MODEL NUMBER	UEF FIRST HOUR RATING G.P.H.	RECOVERY IN G.P.H 90° F RISE	HEIGHT A	HEIGHT TO WATER CONN. B	DIAMETER C	DEPTH D	APPROX. SHIP WT. (LBS.)	UNIFORM ENERGY FACTOR (UEF)
40	36	88H-40D	50	21	36	33	24	25	156	0.81

Uniform Energy Factor and rated gallon capacity based on Department of Energy (DOE) requirements.

- Heaters furnished with standard 240 volt AC, single phase non-simultaneous wiring, and 4500 watt upper and lower heating elements.
- **If heating elements of different wattages than those shown are demanded by zone requirements, they must be specifically requested.**
- Special Wiring Options – A limited number of special wiring options are available. Consult factory for price and availability.
- Sold in U.S. only.

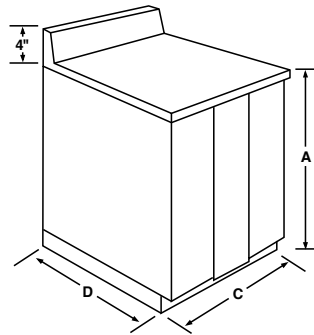
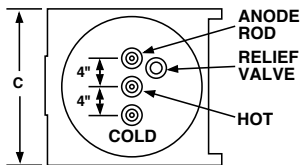

Non-metallic Tank Features

- Seamless, blow-molded, polybutene tank – impervious to rust and corrosion
- Multiple layers of filament wound fiberglass give the tank unmatched strength
- Polyurethane insulation helps reduce energy consumption
- Recessed drain valve is out of the way brooms and scrubbers
- Durable PEX dip tube
- Tough molded polyethylene outer shell resists dents, scratches, and salt air
- Tough molded polyethylene outer shell resists dents, scratches, and salt air

Efficiency for 30 to 100-gallon models

- .88 - .92 UEF
- Well insulated for reduced standby heat loss
- Pipe wrap energy saving kit included to achieve maximum energy savings

Performance for 30 to 100-gallon models

- FHR: 38 - 83 gallons, depending on model
- Recovery: up to 21 GPH at a 90° F rise**

Easy Installation & Service

- Marathon's lightweight tank is easier to maneuver and position
- Bowl shaped tank bottom allows complete sediment draining
- Water tight grommets keep out over-head moisture and condensation

Plus...

- Thermally fused upper element provides protection against dry-firing
- Titanium lower element for superior resistance to lime build-up
- Brass drain valve
- Temperature and pressure relief valve
- Low lead compliant
- Standard replacement parts

Warranty

- Lifetime limited warranty on tank and 6-years on parts*

*Warranty is provided to original customer in a residential application after online product registration is complete. Registration must be completed within 90 days of installation. See Warranty Certificate for complete information

Units meet or exceed ANSI requirements and have been tested according to D.O.E. procedures. Units meet or exceed the energy efficiency requirements of NAECA, ASHRAE standard 90, ICC Code and all state energy efficiency performance criteria.

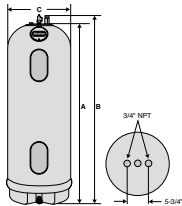
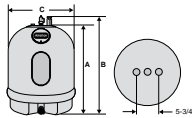

DESCRIPTION				FEATURES		ROUGHING IN DIMENSIONS (SHOWN IN INCHES)				ENERGY INFO.
T Y P E	NOMINAL GALLON CAPACITY	RATED GALLON CAPACITY	MODEL NUMBER	UEF FIRST HOUR RATING G.P.H.	RECOVERY IN G.P.H. 90° F RISE	TANK HEIGHT A	HEIGHT TO WATER CONN. B	DIAMETER C	APPROX. SHIP WT. (LBS.)	UNIFORM ENERGY FACTOR (UEF)
Tall	30	28	MR30238C†	38	17	49	49-1/2	21-5/8	75	0.88
Tall	30	28	MR30245C†	38	21	49	49-1/2	21-5/8	75	0.88
Tall	40	38	MR40245C†	51	21	61-1/2	65-1/2	21-3/4	90	0.92
Tall	50	50	MR50245C†	57	21	62-3/4	66-3/4	23-1/2	100	0.91
Short	50	48	MSR50245C†	41	21	43-1/4	47-1/4	28-1/4	95	0.90
Tall	85	84	MRG85245C*	77	21	66-1/4	70-1/4	28-1/4	134	0.92
Tall	100	101	MRG105245C*	83	21	66-3/4	70-3/4	30-1/4	152	0.90

Point-of-Use Models

DESCRIPTION			FEATURES		ROUGHING IN DIMENSIONS (SHOWN IN INCHES)				ENERGY INFO.
T Y P E	GAL. CAP.	MODEL NUMBER	ELEMENT WATTAGE	VOLTAGE	TANK HEIGHT A	HEIGHT TO WATER CONN. B	DIAMETER C	APPROX. SHIP WT. (LBS)	UNIFORM ENERGY FACTOR (UEF)
POU	15	MR15120	2000	120	31-3/4	35-3/4	21-3/4	58	N/A
POU	19.9	MR20120	2000	120	30-1/2	34-1/2	23-1/2	61	N/A
POU	19.9	MR20230	3000	240	30-1/2	34-1/2	23-1/2	61	N/A

Uniform Energy Factor and rated gallon capacity based on Department of Energy (DOE) requirements.

Canadian models have different model numbers than U.S. models. Add a "C" before the model number (e.g., CMR85245) when ordering.

Water heaters furnished with standard 240 or 120 volt AC, single phase non-simultaneous wiring. If heating elements of different wattages than those shown are demanded, they must be specifically requested. For height to top of T&P and heat traps add 3-1/2" to the height to water connection. Maximum test pressure: 300 PSI. Maximum working pressure: 150 PSI.

*This water heater is intended only for use as part of an electric thermal storage or demand response program. This water heater will not provide adequate hot water unless enrolled in such a program and is activated by your utility company or another program operator. Please confirm the availability of such a program in your local area before purchasing or installing this product.

**Recovery calculations used are based on 4500 watt elements used in non-simultaneous operation.



LEED Point = 1

$$\text{**Recovery} = \frac{\text{wattage}}{2.42 \times \text{temp. rise } ^\circ\text{F.}}$$

Example: $\frac{4500\text{W}}{2.42 \times 90^\circ} = 21 \text{ GPH}$



Water Heater Booster

The Rheem Water Heater Booster works with your tank to provide hot water past the tank's capacity

Installs on Electric or Gas Tank

The Rheem Water Heater Booster installs directly on a tank's hot water line to provide more hot water than the tank alone can provide. The booster delivers nearly double the shower time. The unit senses the temperature of the water from the tank outlet, and activates when it senses that its inlet temperature has dropped below the user set activation temperature.

Product Attributes

- Increase deliverable hot water up to 45%
- Compact design
- Dimensions: 8-1/4" H x 12-5/8" W x 3-5/8" D
- Digital user interface
- Adjustable activation temperature 80-130°F
- Adjustable outlet temperature 80-140°F
- Set temperature in increments of 1°F
- Easy installation on new or existing water heater
- No need for additional electrical infrastructure if installed on existing electric water heater. Additional wiring maybe required for a gas tank installation
- Field replaceable element

Warranty

- 5-Year heating chamber and 1-year parts limited warranty

See Residential Warranty Certificate for complete information



* Based on a 1.5 gallons per minute showerhead.



MODEL NUMBER	VOLTS	PHASE	KW	MAX. AMPS	BREAKER	WEIGHT (LBS.)	PRE-SET OUTLET TEMP.	WATER CONNECTIONS
RTEX-AB7	240 VAC	Single	7.2	30	1X30 AMP Double Pole	5.64	120°	3/4" NPT Fittings

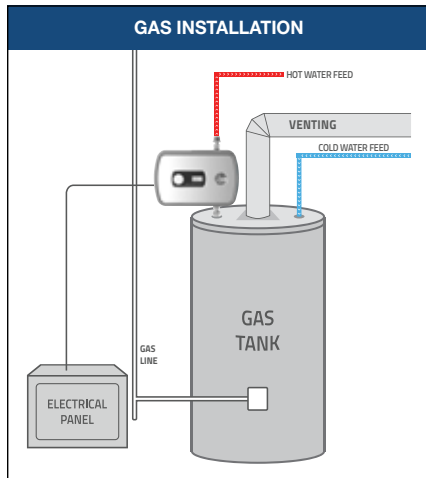
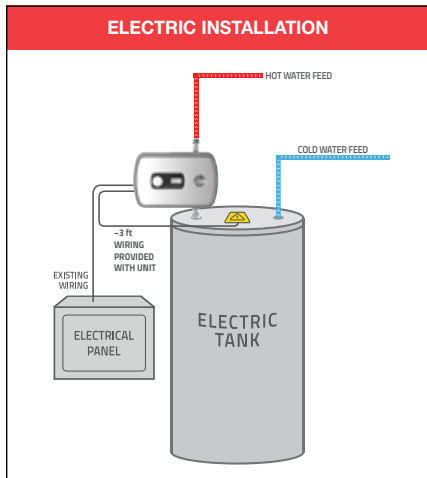

- Unit may be wall mounted if available space is limited.



Professional Classic® Tankless Electric

Performance Features

- On demand, consistent and continuous hot water
- Compact and stylish with digital temperature control in increments of 1°F ranging from 80°F to 140°F*
- Robust copper immersion heating elements with brass top increases durability and are threaded for easy replacement
- Simple Installation
- Digital temperature display
- External controls to adjust temperature in increments of 1°F*

Average GPM Usage by Application

Standard Hand Sink	0.5 GPM
Washing Machine	1 to 1.5 GPM
Water-Saver Shower Head	1.5 GPM
Dishwasher	1 to 2 GPM
Kitchen Sink	1 to 2 GPM
Standard Shower Head	2.0 GPM
Bath Tub	≥ 4 GPM
Whole-Home	Up to 6 GPM

Average Gallons Per Minute (GPM) based on 2010 Plumbing Standards

Warranty

- 5-Year heating chamber and 1-year parts limited warranty

See Residential Warranty Certificate for complete information

**RTEX-04 and RTEX-06 only show output temperature and are non-thermostatically controlled*



Tested and certified by the Water Quality Association against NSF/ANSI 372 for lead free compliance.

MODEL NUMBER	TEMPERATURE RISE °F								
	0.5 GPM	1.0 GPM	1.5 GPM	2.0 GPM	2.5 GPM	3.0 GPM	4.0 GPM	5.0 GPM	6.0 GPM
SINGLE POINT-OF-USE									
RTEX-04	48°	24°	16°	12°	–	–	–	–	–
RTEX-06	75°	37°	25°	19°	–	–	–	–	–
MULTIPLE APPLICATIONS									
RTEX-08	+	55°	36°	27°	22°	18°	14°	–	–
RTEX-11	+	75°	50°	38°	30°	25°	19°	–	–
RTEX-13	+	89°	59°	44°	36°	30°	22°	–	–
RTEX-18	+	+	82°	62°	49°	41°	31°	25°	–
RTEX-24	+	+	109°	82°	66°	55°	41°	33°	27°
RTEX-27	+	+	+	92°	74°	62°	46°	37°	31°
RTEX-36	+	+	+	+	98°	82°	62°	49°	41°

+ Temperature electronically limited setting on adjustable thermostat on front cover

SINGLE POINT-OF-USE
For 0.5 GPM to 2.0 GPM Applications

500
PROCLUB
POINTS



RTEX-04
RTEX-06

MULTIPLE APPLICATIONS
For 1.0 GPM to 6.0 GPM Applications

750
PROCLUB
POINTS



RTEX-08
RTEX-11
RTEX-13



RTEX-18



RTEX-24
RTEX-27



RTEX-36

DESCRIPTION	FEATURES							ROUGHING IN DIMENSIONS (SHOWN IN INCHES)				
MODEL NUMBER	kW	AMPS	RECOMMENDED BREAKER SIZE	VOLTAGE	RECOMMENDED WIRE SIZE (CU)	MIN. FLOW (GPM)	MAX. FLOW (GPM)	HEIGHT	WIDTH	DEPTH	WATER CONN.	SHIP WEIGHT (LBS.)
120V 1 HEATING CHAMBER												
RTEX-04	3.5	29A	(1x30)A	120	10 AWG	0.3	1.5	5-7/8	10-7/8	2-3/4	1/2 NPT	4.5
240V* 1 HEATING CHAMBER												
RTEX-06	5.5	25A	(1x25)A	220	10 AWG	0.3	2.0	5-7/8	10-7/8	2-3/4	1/2 NPT	4.5
RTEX-08*	8.0	33A	(1x40)A	240	8 AWG	0.3	4.8	12-5/8	8-1/4	3-5/8	1/2 CF	7
RTEX-11*	11.0	46A	(1x50)A	240	6 AWG	0.3	4.8	12-5/8	8-1/4	3-5/8	1/2 CF	8.5
RTEX-13*	13.0	54A	(1x60)A	240	6 AWG	0.3	4.8	12-5/8	8-1/4	3-5/8	1/2 CF	8.5
240V* 2 HEATING CHAMBERS												
RTEX-18*	18.0	75A	(2x40)A	240	8 AWG	0.3	7.0	18-1/4	14-1/2	3-1/2	3/4 NPT	14.78
240V* 3 HEATING CHAMBERS												
RTEX-24*	24.0	100A	(3x40)A	240	8 AWG	0.3	7.0	18-1/4	17-5/8	3-1/2	3/4 NPT	17.8
RTEX-27*	27.0	112A	(3x40)A	240	8 AWG	0.3	7.0	18-1/4	17-5/8	3-1/2	3/4 NPT	17.8
240V* 4 HEATING CHAMBERS												
RTEX-36*	36.0	150A	(4x40)A	240	8 AWG	0.3	8.0	18-1/4	21-5/8	3-1/2	3/4 NPT	22.7

*240V units can be used on 208V single phase with 25% reduced temperature output. Please note per UL standards the rating plate and installation instructions will all be according to a 240V applied voltage. Check with local officials prior to derating the electrical infrastructure.



SolPak™ Active System with Electric Backup

System

- Closed loop system – glycol design
- Single and double collector systems
- System includes – Solaraide HE tank, collectors and pump station

Heat Exchanger Tank

- 65, 80 and 120-Gallon capacities
- 4500 Watts
- Provides at least 40 gallons of stored hot water
- Double wall, high efficiency solar heat exchanger includes copper tubing wrapped around the tank and secured within the jacket for positive leak protection
- Collector feed and return fittings conveniently located on front of tank for easy installation
- Cold water inlet brings cold water to tank bottom to prevent mixing with heated water
- Rheemglas® tank lining resists corrosion and prolongs tank life
- T&P Valve included
- Low lead compliant
- Automatic temperature control and over heat protection

Collector

- OG-100 certified by SRCC
- Available in three sizes
- Durable low iron tempered glass – improves efficiency and heat transfer
- Integral mounting channel for easy installation
- Stainless steel fasteners
- Type-M copper riser tubes
- Black paint absorber coating

Pump Station

- Pre-engineered assembly of quality components in a neat, compact insulated enclosure
- Simple, labor saving, attractive solution for closed loop glycol solar systems
- Includes cast iron three speed pump, advanced differential controller and balancing valve and flow meter

System Certifications

- OG-300 certification by SRCC

Warranty

- 6-Year limited tank, 10-year limited collector and 6-year limited pump station warranty.*

*See Residential and SolPak Warranty Certificate for complete information



SYSTEM INFORMATION			COLLECTOR INFORMATION											WATER HEATER INFO.			
STORAGE CAPACITY (US GAL)	SYSTEM MODEL NUMBER	SOLAR ENERGY FACTOR*	NUMBER OF COLLECTOR PANELS	ABSORBER COATING	WIDTH (INCHES)	LENGTH (INCHES)	DEPTH (INCHES)	AREA SQ. FT. (GROSS)	DRY WEIGHT (LBS)	FLUID CAPACITY (US GAL)	DESIGN FLOW RATE (GPM)	MAX FLOW RATE (GPM)	MAX. OPERATING PRESSURE	HEIGHT (INCHES)	DIAMETER (INCHES)	APPROX. WEIGHT (LBS)	ELEMENT WATTAGE
65	RS65-24BP	1.4	1	Black Paint	36-1/8	98-1/4	3-1/4	24.61	80	.78	0.62	12	160	59	21	170	4500 W
65	RS65-32BP	1.7	1	Black Paint	48-1/8	98-1/4	3-1/4	32.19	106	1.0	0.83	12	160	59	21	170	4500 W
65	RS65-40BP	1.9	1	Black Paint	48-1/8	122-1/4	3-1/4	40.81	191	1.2	1.04	12	160	59	21	170	4500 W
80	RS80-40BP	2.4	1	Black Paint	48-1/8	122-1/4	3-1/4	40.81	141	1.2	1.04	12	160	58-3/4	24-1/2	222	4500 W
80	RS80-48BP	2.6	2	Black Paint	36-1/8	98-1/4	3-1/4	24.61	80	.78	0.62	12	160	58-3/4	24-1/2	222	4500 W
120	RS120-64BP	3.2	2	Black Paint	48-1/8	98-1/4	3-1/4	32.79	106	1.0	0.83	12	160	62	28-1/4	380	4500 W

*As rated by the Solar Rating & Certification Corporation (SRCC)

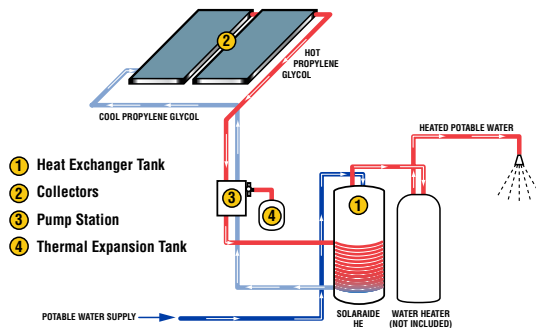

SolPak™ Active System with Gas Backup

System

- Closed loop system – glycol design
- Fast recovery for high demand situations
- Perfect replacement for current gas water heating system
- System includes – Solaraide® HE gas storage tank, collectors and pump station

Heat Exchanger Tank

- 75-Gallon capacity
- 75.1 BTU/h – natural gas
- Double wall, high efficiency solar heat exchanger
- Low NOx burner design
- Gas backup heating source
- Rheemglas® tank lining resists corrosion and prolongs tank life
- T&P Valve included
- Low lead compliant
- Automatic temperature control and over heat protection

Collector

- OG-100 certified by SRCC
- Available in two sizes
- Durable low iron tempered glass – improves efficiency and heat transfer
- Integral mounting channel for easy installation
- Stainless steel fasteners
- Type-M copper riser tubes
- Black paint absorber coating

System Certifications

- OG-300 certification by SRCC

Pump Station

- Pre-engineered assembly of quality components in a neat, compact insulated enclosure
- Simple, labor saving, attractive solution for closed loop glycol solar systems
- Includes cast iron three speed pump, advanced differential controller and balancing valve and flow meter

Warranty

- 6-Year limited tank, 10-year limited collector and 6-year limited pump station warranty.*

*See Residential and SolPak Warranty Certificate for complete information



SYSTEM INFORMATION			COLLECTOR INFORMATION											WATER HEATER INFO.			
STORAGE CAPACITY (US GAL)	SYSTEM MODEL NUMBER	SOLAR ENERGY FACTOR	NUMBER OF COLLECTOR PANELS	ABSORBER COATING	WIDTH (INCHES)	LENGTH (INCHES)	DEPTH (INCHES)	AREA SQ. FT. (GROSS)	DRY WEIGHT (LBS)	FLUID CAPACITY (US GAL)	DESIGN FLOW RATE (GPM)	MAX FLOW RATE (GPM)	MAX. OPERATING PRESSURE	HEIGHT (INCHES)	DIAMETER (INCHES)	APPROX. WEIGHT (LBS)	BTU/h INPUT
75	RSG75-48BP	-	2	Black Paint	36-1/8	98-1/4	3-1/4	24.61	80	.78	0.62	12	150	60	26-1/4	340	75.1
75	RSG75-40BP	-	1	Black Paint	48-1/8	122-1/4	3-1/4	40.81	141	1.20	1.04	12	160	60	26-1/4	340	75.1

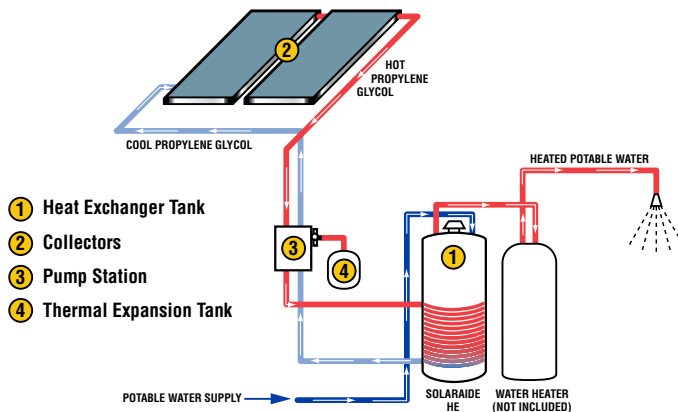

Solar Collectors

Features

- OG-100 certified by SRCC
- Durable low iron tempered glass – improves efficiency and heat transfer
- Integral mounting channel for easy installation
- Stainless steel fasteners
- Suitable for open and closed loop systems
- Type-M copper riser tubes
- Copper absorber plate – allows collector to be used in glycol forced circulation, drain-back, or open loop systems
- Can be mounted horizontally or vertically
- BP and BC Series – available in three sizes

Warranty

- 10-Year limited collector warranty*

*See Residential Warranty Certificate for complete information

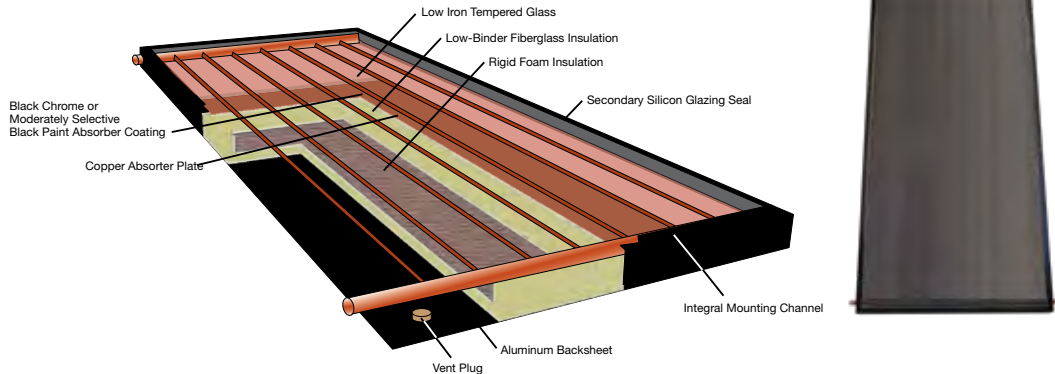

MODEL NUMBER	ABSORBER COATING	WIDTH (INCHES)	LENGTH (INCHES)	DEPTH (INCHES)	AREA SQ. FT.	DRY WEIGHT (LBS.)	FLUID CAPACITY	DESIGN FLOW RATE (GPM)	MAX FLOW RATE (GPM)	MAX OPERATING PRESSURE
RS24-BP	Black Paint	36-1/8	98-1/4	3-1/4	24.61	80	0.78	0.62	12	160
RS32-BP	Black Paint	48-1/8	98-1/4	3-1/4	32.79	106	1	0.83	12	160
RS40-BP	Black Paint	48-1/8	122-1/4	3-1/4	40.81	141	1.2	1.04	12	160

THERMAL PERFORMANCE RATINGS* BP SERIES (BTU / FT ² / DAY)			
CATEGORY (TI-TA) TI = INLET FLUID TEMP. TA = AMBIENT AIR TEMP.	CLEAR DAY 2000 BTU / FT ² / DAY	MILDLY CLOUDY DAY 1500 BTU / FT ² / DAY	CLOUDY DAY 1000 BTU / FT ² / DAY
A (-9°F)	1,284	971	659
B (9°F)	1,169	854	542
C (36°F)	984	677	372
D (90°F)	619	343	89
E (144°F)	280	62	-

THERMAL PERFORMANCE RATINGS* BC SERIES (BTU / FT ² / DAY)			
CATEGORY (TI-TA) TI = INLET FLUID TEMP. TA = AMBIENT AIR TEMP.	CLEAR DAY 2000 BTU / FT ² / DAY	MILDLY CLOUDY DAY 1500 BTU / FT ² / DAY	CLOUDY DAY 1000 BTU / FT ² / DAY
A (-9°F)	1332	1,005	680
B (9°F)	1,218	890	565
C (36°F)	1,040	720	402
D (90°F)	699	405	127
E (144°F)	390	137	-

Thermal performance is obtained by multiplying the collector output for the appropriate application and insulation level by the total gross collector area.

*Collector ratings are derived from the Solar Rating & Certification Corp (SRCC) Document RM-1 and Standard OG-100



Solaraide® HE Tanks

Features & Benefits

- Double wall heat exchanger includes copper tubing wrapped around the tank and secured within the jacket for positive leak protection
- Two well insulated models to choose from... a storage tank or a high efficiency 4500 Watt backup electric water heater
- Electric backup model provides at least 40-gallons of stored hot water

Easy Installation and Maintenance

- Collector feed and return fittings conveniently located on front of tank for easy installation
- A special 1/2" NPT opening is provided for installation of a "probe type" thermostat
- Durable brass drain valve for easy maintenance

Tank Design & Construction

- Cold water inlet brings cold water to tank bottom to prevent mixing with heated water
- Rheemglas® tank lining resists corrosion and prolongs tank life
- Anode rod equalizes aggressive action for prolonged tank life
- Temperature and pressure relief valve included
- Electric backup model has automatic temperature control and over heat protection
- Low lead compliant

Warranty

- 6-Year limited tank and parts warranty*

*See Residential Warranty Certificate for complete information

Units meet or exceed ANSI requirements and have been tested according to D.O.E. procedures. Units meet or exceed the energy efficiency requirements of NAECA, ASHRAE standard 90, ICC Code and all state energy efficiency performance criteria.

Copper Heat Exchanger Coil Type L Copper 5/8" I.D.

SOLARAIDE HE TANK CAPACITY	COIL CAPACITY GALLONS	LENGTH OF TUBING AROUND TANK (FT)
65 Gallons	2.2	120
80 Gallons	2.2	120
120 Gallons	2.6	143

PRESSURE DROP THROUGH COIL (FEET OF H ₂ O)		
FLOW RATE	HEAD LOSS (FEET)	
	65 & 80-GALLON	120-GALLON
1 GPM	1.3	1.6
2 GPM	4.8	5.7
3 GPM	10.0	12.0

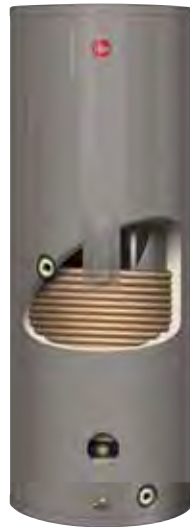

DESCRIPTION				ROUGHING IN DIMENSIONS (SHOWN IN INCHES)			ENERGY INFO.
T Y P E	GAL. CAP.	MODEL NUMBER	ELEMENT WATTAGE UPPER	HEIGHT A	DIAMETER B	APPROX SHIP WT. (LBS)	APPROX. R-FACTOR
Tall	65	82V65HE	4500 W*	59	21	170	R-17.3
Tall	80	81V80HE-1	4500 W*	58-3/4	24-1/2	222	R-17.3
Tall	80	81V80HE-T	Storage only	58-3/4	24-1/2	222	R-17.3
Tall	120	82V120HE-1	4500 W*	62	28-1/4	380	R-17.3
Tall	120	82V120HE-T	Storage only	62	28-1/4	380	R-17.3

*Heaters furnished with standard 240 volt AC, single phase non-simultaneous wiring and 4500 watt heating element. If heating elements of different wattages than those shown are demanded by zone requirements, they must be specifically requested.

To prevent corrosion, proper pH levels in transfer fluid must be maintained. Solaraide models meet all current state requirements for solar storage tanks. The tanks are Rheemglas lined and are designed to operate up to 150 PSI.

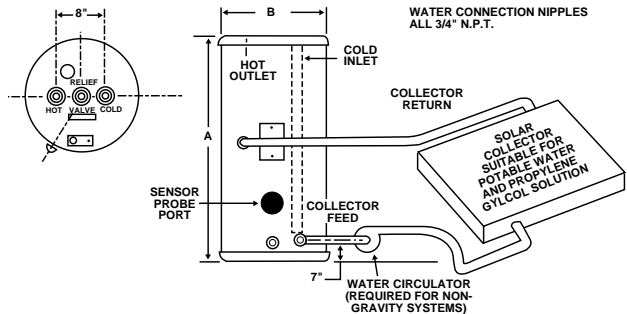

Solaraide® HE with Gas Assist

Features & Benefits

- Double wall, high efficiency solar heat exchanger
- Fast recovery, 75-gallon capacity for high demand applications
- For use in residential closed loop solar water heating systems

Easy Installation and Maintenance

- Front solar connections for easy installation
- Durable brass drain valve for easy maintenance

Tank Design & Construction

- Low NOx burner design
- Cold water inlet brings cold water to tank bottom to prevent mixing with heated water
- Rheemglas® tank lining resists corrosion and prolongs tank life
- Anode rod equalizes aggressive action for prolonged tank life
- Temperature and pressure relief valve included
- Automatic temperature control and over heat protection
- Low lead compliant

Guardian System® & Sensor

- Exclusive air/fuel shut-off device
- Maintenance free – no filter to clean
- Disables the heater in the presence of flammable vapor accumulation

Warranty

- 6-Year limited tank and parts warranty*

*See Residential Warranty Certificate for complete information

Units meet or exceed ANSI requirements and have been tested according to D.O.E. procedures. Units meet or exceed the energy efficiency requirements of NAECA, ASHRAE standard 90, ICC Code and all state energy efficiency performance criteria.

Copper Heat Exchanger Coil Type L Copper 5/8" I.D.

Maximum pressure = 150 PSI

SOLARAIDE HE TANK CAPACITY	COIL CAPACITY GALLONS	LENGTH OF TUBING AROUND TANK (FT)
75 Gallons	2.2	120

PRESSURE DROP THROUGH COIL (FEET OF H ₂ O)	
FLOW RATE	HEAD LOSS (FEET)
	75-GALLON
1 GPM	1.3
2 GPM	4.8
3 GPM	10.0



DESCRIPTION			FEATURES				ROUGHING IN DIMENSIONS (SHOWN IN INCHES)									
T Y P E	GAL. CAP.	MODEL NUMBER	GAS INPUT IN THOUS. BTU/h NAT.	RECOVERY IN G.P.H. 90° RISE	FIRST HOUR DELIVERY G.P.H. NAT.	HT. TO VENT A	TANK HT. B	DIAM. C	HT. TO GAS CONN. D	VENT SIZE E	WATER CONN. CNTR. F	HT. TO SIDE T&P G	WATER CONN. H	HT. TO HEAT EXCHANGER INLET	HT. TO HEAT EXCHANGER OUTLET	SHIP. WT. (LBS)
Tall	75	RSG75	75.1	75.8	75.8	64	60	26-1/4	32	4	11	53-1/4	1	31	12	340

To prevent corrosion, proper pH levels in transfer fluid must be maintained. Solaraide models meet all current state requirements for solar storage tanks.

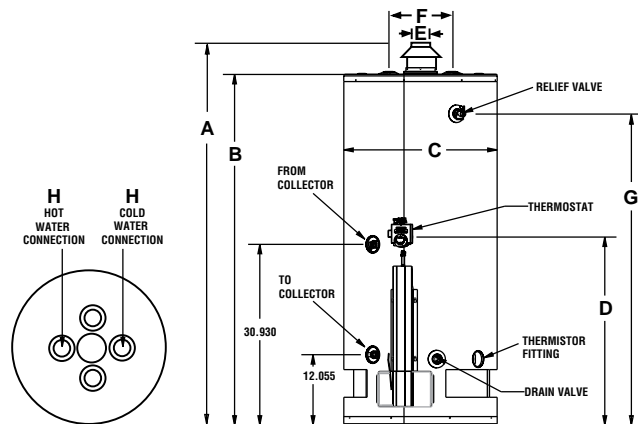

Solaraide® Storage Tanks

Features & Benefits

- Connection ports on the top, right and left side fit more installations and reduce SKUs
- Two well insulated models to choose from... a storage tank or a high efficiency 4500 Watt backup electric water heater
- Electric backup model provides at least 40-gallons of stored hot water

Easy Installation and Maintenance

- Collector feed and return fittings conveniently located on front of tank for easy installation
- A special 1/2" NPT opening is provided for installation of a "probe type" thermostat
- Durable brass drain valve for easy maintenance

Tank Design & Construction

- Cold water inlet brings cold water to tank bottom to prevent mixing with heated water
- Uses the potable water within the tank for circulation through the solar system
- Rheemglas® tank lining resists corrosion and prolongs tank life
- Anode rod equalizes aggressive action for prolonged tank life
- Temperature and pressure relief valve included
- Electric backup model has automatic temperature control and over heat protection
- Low lead compliant

Warranty

- 6-Year limited tank and parts warranty*

*See Residential Warranty Certificate for complete information

Units meet or exceed ANSI requirements and have been tested according to D.O.E. procedures. Units meet or exceed the energy efficiency requirements of NAECA, ASHRAE standard 90, ICC Code and all state energy efficiency performance criteria.



DESCRIPTION				ROUGHING IN DIMENSIONS (SHOWN IN INCHES)					ENERGY INFO.	
T Y P E	GAL. CAP.	MODEL NUMBER	ELEMENT WATTAGE UPPER	HEIGHT A	DIAMETER B	HEIGHT TO CONNECTOR FEED C	HEIGHT TO COLLECTOR RETURN D	APPROX SHIP WT. (LBS)	APPROX. R-FACTOR	
Tall	80	81VR80U-1	4500 W*	58-3/4	24-1/2	3	38-1/4	192	R-17.3	
Tall	80	81VR80U-T	Storage Only	58-3/4	24-1/2	3	38-1/4	192	R-17.3	
Tall	120	81VR120U-1	4500 W*	62	28-1/4	3-3/4	38-1/2	336	R-16.7	
Tall	120	81VR120U-T	Storage Only	62	28-1/4	3-3/4	38-1/2	336	R-16.7	

*Heaters furnished with standard 240 volt AC, single phase non-simultaneous wiring and 4500 watt heating element.

If heating elements of different wattages than those shown are demanded by zone requirements, they must be specifically requested.

Solaraide models meet all current requirements for solar storage tanks.

The tanks are Rheemglas lined and are designed to operate up to 150 PSI.

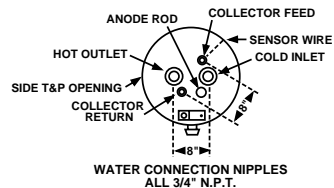
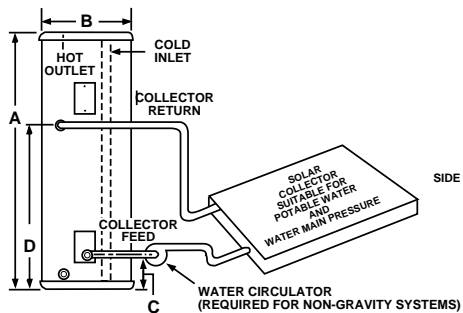

Marathon® Thermal Storage Tank

Designed for Alternative Energy Applications

- Specifically designed for installation as a thermal storage tank
- Backup electrical element provides 40 gallons or more of heated water
- Large water connections for lower pressure drop

Built to Last!

- Seamless, blow-molded, polybutene tank – impervious to rust and corrosion
- Titanium sheath elements for superior resistance to lime build-up
- Multiple layers of filament wound fiberglass give the tank unmatched strength
- Tough molded polyethylene outer shell resists dents and scratches

Designed for Easy installation

- Lightweight
- Water port fittings located at front of storage tank for convenient access
- Full port, full flow brass drain valve for fast draining
- Factory installed temperature and pressure relief valve and vacuum relief valve

Plus...

- Thermally fused element provides protection against “dry-firing”
- Bowl shaped bottom allows for complete sediment removal
- Recessed drain valve is out of the way of brooms and scrubbers
- Low lead compliant

Warranty

- Lifetime limited tank and 6-year limited parts warranty

*See Residential Warranty Certificate for complete information

Units meet or exceed ANSI requirements and have been tested according to D.O.E. procedures. Units meet or exceed the energy efficiency requirements of NAECA, ASHRAE standard 90, ICC Code and all state energy efficiency performance criteria.



DESCRIPTION			FEATURES	ROUGHING IN DIMENSIONS (SHOWN IN INCHES)					
T Y P E	GAL. CAP.	MODEL NUMBER	ELEMENT WATTAGE	TANK HEIGHT A	HEIGHT TO WATER CONN. B	DIAMETER C	HEIGHT TO LOWER PORT D	HEIGHT TO UPPER PORT E	APPROX. SHIP WT. (LBS)
Tall	50	MTS50200	N/A	62-3/4	66-3/4	23-1/2	13-1/2	46	100
Tall	85	MTS85200	N/A	66-1/4	70-1/4	28-1/4	14-1/2	49-1/2	134
Tall	105	MTS105200	N/A	66-3/4	70-3/4	30-1/4	15	50	152
Tall	85	MTS85245	4500	66-1/4	70-1/4	28-1/4	14-1/2	N/A	134
Tall	105	MTS105245	4500	66-3/4	70-3/4	30-1/4	15	N/A	152
Tall	85	MTS85345	4500	66-1/4	70-1/4	28-1/4	14-1/2	26-1/2	134
Tall	100	MTS105345	4500	66-3/4	70-3/4	30-1/4	15	27-1/2	152

Canadian certified models have different model numbers than U.S. models. Add a "C" before the model number (e.g., CMTS85245) when ordering.

Canadian certified models are not available on thermal storage tanks without backup elements (e.g., MTS50200, MTS85200, MTS105200)

- Storage tanks furnished with elements are standard 240 volt AC.
- Maximum test pressure: 300 PSI, maximum working pressure: 150 PSI, maximum water temperature: 180° F

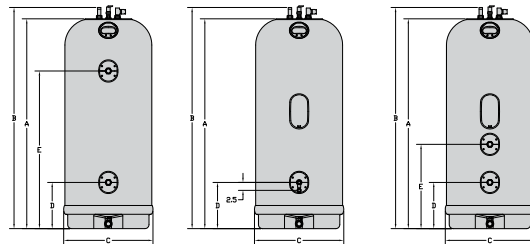

ProtectionPlus®

ProtectionPlus® is a 4-year warranty extension kit to be used for new Rheem water heater installations

Warranty Extension

- 6-Year limited tank warranty becomes 10-year
- 8-Year limited tank warranty becomes 12-year
- For use on all Rheem residential models except Manufactured Housing, Marathon, Point-of-Use, Hybrid Electric, Table Top, Condensing Gas Models, Tankless or Thermal Expansion Tanks

The Kit Contains

- High quality magnesium anode rod with plastic lined nipple (hot side)
- Plastic lined nipple (cold side)
- Brass 3/4" to 1" adaptor
- Warranty certificate with instructions
- ProtectionPlus® label to be placed on water heater

Advantages

- Provides up to 135% additional anodic protection
- With just two water heaters, you have the option of selling four warranty periods
- Effectively have four water heaters in little more space than two

ProtectionPlus®		
6	Year Limited Tank Warranty Becomes	10
8	Year Limited Tank Warranty Becomes	12

Part Number: SP20866
(Sold only in 6 package quantity)



EverKleen® System

EverKleen® self-cleaning water heating system fights harmful sediment build-up with a high velocity spiraling water stream



Sediment build-up in a water heater creates layers of non-conducting material between the water and the energy that heats the water. This causes a reduction of heat transfer which increases tank bottom temperatures and decreases water temperatures. When this occurs, the results are decreased water heater efficiency and decreased tank life.



The EverKleen® system helps to dislodge this sediment by channeling water through a specially developed inlet tube. This tube creates a high-velocity spiraling water stream which strikes the bottom of the water heater tank with sediment busting force.



The spiraling effect also creates better mixing throughout the water heater tank which reduces the effects of stacking. Stacking occurs when frequent small draws of water create different temperatures throughout the tank resulting in increased peak temperatures at the top of the tank. The EverKleen® system greatly reduces peak temperatures, thus increases first hour deliverability.

Advantages

Water Heating System

- Fights sediment build-up
- Helps preserve operating efficiency
- Helps improve tank life
- Provides increased deliverability



Lifeguard™ Electric Element

Low watt density design delivers full watt-rated heating power to a larger surface area, eliminating high heat concentrations and prolonging element life.*

*See Residential Warranty Certificate for complete information.

High density *nichrome* wire electric heating filament; best grade A, 80/20 nichrome wire made...for top performance and long-life operation.

High-grade magnesium oxide packing moves the heat quickly to the element's surface, protecting the *nichrome* wire filament and boosting efficiency.

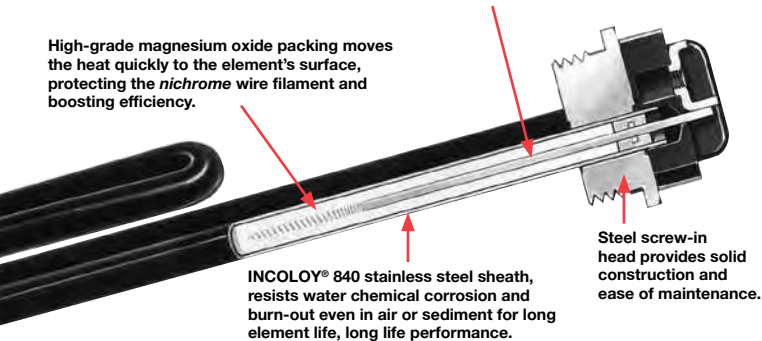

INCOLOY® 840 stainless steel sheath, resists water chemical corrosion and burn-out even in air or sediment for long element life, long life performance.

Steel screw-in head provides solid construction and ease of maintenance.

Accessories

Catch Pan

Available in 5 sizes to help protect any installation area from possible water damage. Each 2" deep drain pan is manufactured of aluminum and fitted with a 1" drain outlet. Provides that extra level of protection assurance that many homeowners and apartment dwellers are looking for. Available in 18", 20", 22", 24", and 26 1/2" diameters. Our specially designed, tapered side wall allows for one-inside-the-other stacking and minimal storage area. Available with side drain outlet.



Catch pan must conform to local codes

Wall Mounting Kit

For Point-of-Use Electric Water Heaters

This wall mounting kit for point-of-use electric water heater installations provides an easy way to mount the unit off the floor, out of the way for more usable floor space in a small area. It's been designed for use with 6, 10, 15, and 20 gallon models (AS-36111) and all walls with 16" stud centers. All necessary parts are included in this easy to install, time-and-money saving kit.



Thermal Expansion Tanks

Features

- The Therm-X-Guard is designed to provide control of maximum pressures at a level below the relief valve setting. Therefore, the relief valve does not open and spillage is eliminated. It also provides additional space in the system to accommodate the increased volume of water created by thermal expansion, returning it to the system upon demand.
- Suitable with water heaters up to 120 gallon capacity and supply pressure to 80 P.S.I.
- Easy to install – and are maintenance free

- The safest and most cost effective way to eliminate problems associated with thermal expansion in closed loop systems
- Protects water heater and plumbing fixtures from premature failure
- Low lead compliant

Warranty

- 5-Year limited tank and parts warranty*

*See Residential Warranty Certificate for complete information



(RRT-5,
RRT-12
Liner only)

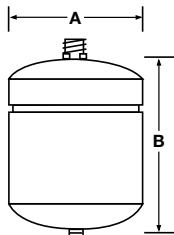

MODELS:
RRT-5
RRT-12

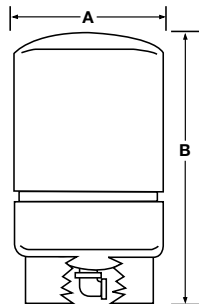

MODEL:
RRT-25



MODEL NUMBER	TOTAL VOLUME (GALLONS)	MAXIMUM ACCEPTANCE (GALS.)	OPERATING TEMPERATURE	WORKING PRESSURE (PSIG)	DIAMETER (A)	HEIGHT (B)	SHIP. WT.	SYSTEM CONNECTION (BRASS)	STANDARD FACTORY PRE-CHARGE (2.8 KG/CM ²)	DIAPHRAGM MATERIAL	LINER MATERIAL
RRT-5	2.0	.9	200°F (93°C)	150 (10.5kg/cm ²)	8"	12-5/8"	5	3/4" NPTM	40 PSIG	Butyl Rubber	Polypropylene
RRT-12	4.4	3.2	200°F (93°C)	150 (10.5kg/cm ²)	11"	15"	9	3/4" NPTM	40 PSIG	Butyl Rubber	Polypropylene
RRT-25	10.3	10.3	200°F (93°C)	150 (10.5kg/cm ²)	15-3/8"	19-1/4"	23	1" NPTF	40 PSIG	Butyl Rubber	Polypropylene

Maximum Working Pressure: 150 PSI. All Models listed by NSF 61; Maximum Allowable Working Temperature: 200°F; Standard Factory Precharge: 40 PSIG

Triton Ultra High Efficiency (SU and SS Series)

Features

- Up to 98% thermal efficiency
- 80 and 100-Gallon capacities
- Base SU model with LeakSense™
- Premium SS model: LeakSense™, LeakGuard™ with smart auto shutoff valve and Integrated BMS Connectivity Via BACnet (MS/TP)
- 130,000-399,900 BTU/h inputs
- Sealed combustion system
- Multiple connection points at the top, side and bottom of the unit simplify installation
- Ultra low NOx burner
- Variety of Flexible Venting Options – Polypropylene, PVC, CPVC, InnoFlue® Flex Vent and ABS materials; venting 2, 3, 4 and 6 inch diameters
- Triple Pass Heat Exchanger – Constructed with premium ASME-grade steel
- Full modulation
- EcoNet® smart monitoring technology with integrated WiFi provides performance updates and alerts via both mobile device and full-color LCD display
- Certified up to 8,999 feet above sea level
- ½-Inch gas connection
- Natural and LP models

- Maximum temperature setting 185°F
- Meets 14 ng/J NOx requirements
- SCAQMD Rule 1146.2 compliant
- NSF Rated
- Meets Massachusetts specifications

Warranty

- SU Models: 3-Year limited tank warranty*
- SS Models: 5-Year limited tank warranty*

*See Commercial Warranty Certificate for complete information

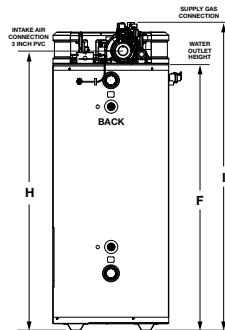
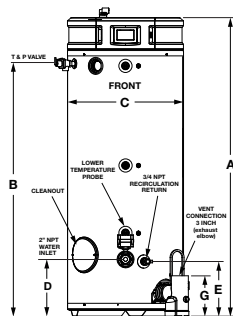

RECOVERY CAPACITIES							DIMENSIONAL INFORMATIONS (Shown in English Inches)													
MODEL NUMBER	GAL. CAP.	INPUT (BTU/H) NAT. & LP	THERMAL EFFIC.	TEMP. RISE – G.P.H.			A	B	C	D	E	F	G	H	I	VENT	SIDE WATER CONNECTION		TOP OUTLET (NPT)	APPROX. SHIP. WT. (LB)*
				40°F	100°F	140°											INLET (NPT)	OUTLET (NPT)		
★ GHE80SU/SS-130(A)	80	130,000	98%	382	153	109	67-7/8	57.43	26-3/8	13	12-1/2	60-1/2	10-5/8	63-5/8	70-1/16	2, 3, 4	2"	2"	1.5"	600
★ GHE80SU/SS-160(A)	80	160,000	97%	465	186	133	67-7/8	57.43	26-3/8	13	12-1/2	60-1/2	10-5/8	63-5/8	70-1/16	2, 3, 4	2"	2"	1.5"	600
★ GHE80SU/SS-200(A)	80	199,900	95%	576	230	165	67-7/8	57.43	26-3/8	13	12-1/2	60-1/2	10-5/8	63-5/8	70-1/16	2, 3, 4	2"	2"	1.5"	650
★ GHE80SU/SS-300(A)	80	300,000	95%	855	342	244	67-7/8	57.43	26-3/8	13	12-1/2	60-1/2	10-5/8	63-5/8	70-1/16	3, 4, 6	2"	2"	1.5"	650
★ GHE100SU/SS-130(A)	100	130,000	97%	382	153	109	77	66-3/4	26-3/8	13	12-1/2	69.80	10-5/8	72-3/4	77-1/2	2, 3, 4	2"	2"	1.5"	725
★ GHE100SU/SS-160(A)	100	160,000	97%	470	188	134	77	66-3/4	26-3/8	13	12-1/2	69.80	10-5/8	72-3/4	77-1/2	2, 3, 4	2"	2"	1.5"	725
★ GHE100SU/SS-200(A)	100	199,900	97%	582	233	166	77	66-3/4	26-3/8	13	12-1/2	69.80	10-5/8	72-3/4	77-1/2	2, 3, 4	2"	2"	1.5"	775
★ GHE100SU/SS-250(A)	100	250,000	96%	727	291	208	77	66-3/4	26-3/8	13	12-1/2	69.80	10-5/8	72-3/4	77-1/2	3, 4, 6	2"	2"	1.5"	775
★ GHE100SU/SS-300(A)	100	300,000	96%	873	349	249	77	66-3/4	26-3/8	13	12-1/2	69.80	10-5/8	72-3/4	77-1/2	3, 4, 6	2"	2"	1.5"	775
★ GHE100SU/SS-400(A)	100	399,900	95%	1139	456	326	77	66-3/4	26-3/8	13	12-1/2	69.80	10-5/8	72-3/4	77-1/2	3, 4, 6	2"	2"	1.5"	775

★ ENERGY STAR® compliant model.

*Weights listed are for non-ASME. Add 35 lbs. for ASME models.



Super Duty Ultra High Efficiency (GHE Series)

Features

- 93% Thermal efficiency
- 500,000 BTU/h
- 119 and 125-Gallon capacities
- 180° F Maximum temperature setting
- Sealed combustion system
- Ultra low NOx burner
- All models vent with standard 4" or 6" diameter PVC plastic pipe
- Can be installed with Power Vent or Power Direct Vent configurations
- LCD user interface to monitor key functions and components
- Helical-fin three stage heat exchanger to optimize heat transfer and efficiency
- Magnesium anode rods
- Multiple water connections
- Factory installed brass drain valve
- Certified up to 2,000 feet above sea level; 7,800 feet for high altitude models
- Low lead compliant
- Natural and LP models

Warranty

- 3-Year limited tank and 1-year limited parts warranty*

*See Commercial Warranty Certificate for complete information

Gas-Fired



AMPI CERTIFIED



ASME (OPTIONAL)

Low Lead Compliant

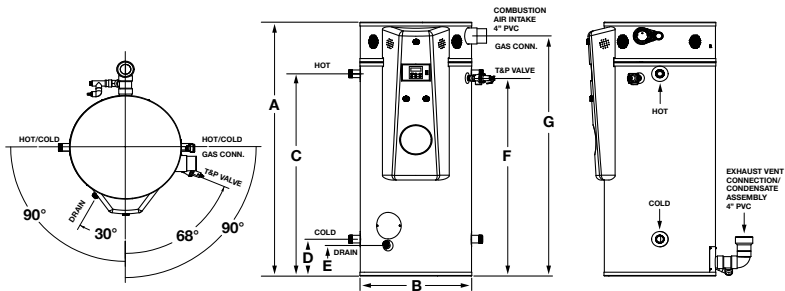

RECOVERY CAPACITIES							DIMENSIONAL INFORMATION (All dimensions shown in inches)											
MODEL NUMBER	GAL. CAP.	INPUT (BTU/h) NAT. & LP	THERMAL EFFIC.	TEMP. RISE – G.P.H.			A	B	C	D	E	F	G	VENT	CONNECTIONS			APPROX. SHIP. WT. (LBS)*
				40° F	100° F	140° F									COLD	HOT	GAS	
GHE119-500	119	500,000	93%	1409	564	403	78.50	32.00	62.78	11.43	9.43	61.43	74.00	4	2	2	1-1/2	1,200
GHE125-500A	125	500,000	93%	1409	564	403	78.50	32.00	62.78	11.43	9.43	61.43	74.00	4	2	2	1-1/2	1,200

*Weights listed are for non-ASME. Add 35 lbs. for ASME models.

Minimum And Maximum Vent and Air Intake Pipe Lengths (4" Pipe)

MODEL NUMBER	FUEL TYPE	VENT ARRANGEMENT	MIN. EQUIVALENT PIPE LENGTH (PER PIPE RUN)		MAX. EQUIVALENT PIPE LENGTH (PER PIPE RUN)	
			AIR INTAKE ¹ (FT.)	VENT ² (FT.)	AIR INTAKE ¹ (FT.)	VENT ² (FT.)
GHE119-500	NAT. or LP	DIRECT VENT	20	20	50 [†]	50 [†]
GHE125-500A	NAT. or LP	POWER VENT	0	20	0	100

¹ Equivalent length is measured **between** the 4" pipe connection on the water heater and the required 90° elbow termination fitting.

² Equivalent length is measured **after** the point of connection to the condensate assembly and includes the termination fitting (if used).

[†] Shown as a balance system. Vent length may exceed air intake length if total combined length does not exceed 100 feet.

Intake length cannot exceed exhaust length.

Minimum And Maximum Vent and Air Intake Pipe Lengths (6" Pipe)

MODEL NUMBER	FUEL TYPE	VENT ARRANGEMENT	MIN. EQUIVALENT PIPE LENGTH (PER PIPE RUN)		MAX. EQUIVALENT PIPE LENGTH (PER PIPE RUN)	
			AIR INTAKE ³ (FT.)	VENT ⁴ (FT.)	AIR INTAKE ³ (FT.)	VENT ⁴ (FT.)
GHE119-500	NAT. or LP	DIRECT VENT	50	50	120 [†]	120 [†]
GHE125-500A	NAT. or LP	POWER VENT	0	50	0	240

³ Equivalent length is measured **between** the 4" pipe connection on the water heater and the required 90° elbow termination fitting.

⁴ Equivalent length is measured **after** the point of connection to the condensate assembly and includes the termination fitting (if used).

[†] Shown as a balance system. Vent length may exceed air intake length if total combined length does not exceed 240 feet.

Intake length cannot exceed exhaust length.



AdvantagePlus™ Ultra High Efficiency (HE Series)

Features

- 95% Thermal efficiency
- 100,000-199,000 BTU/h
- 55, 80 and 119-Gallon capacities
- Temperature setting from 70° to 160° F
- 180° F Maximum temperature setting available on HE55-160 and HE55-199 models with booster kit
- 2" Non-CFC, polyurethane foam insulation reduces standby heat loss
- Self-diagnostic electronic control with HSI ignition control and diagnostics
- The heart of the system is a coil heat exchanger, which is constructed of corrosion resistant, high efficiency, 90/10 cupronickel
- Stainless steel tank construction requires no anode rods. Durable plastic exterior shell
- Removable front cover allows for easy access to equipment (24 inches of service clearance is recommended)
- No chimney required – vents through standard PVC, CPVC and ABS pipes, with a vent run up to 85 feet total for exhaust and intake
- Install as a two pipe power direct vent when air quality or negative air pressure are issues

- Optional concentric vent kits are available for side or vertical venting
- Optional aluminum outside vent termination kit
- Low water cut-off on all models
- Low lead compliant
- Natural and LP models
- Design reduces NOx emissions to less than 14 ng/J. (SCAQMD Rule 1146.2 compliant)
- Zero clearance to combustibles
- Certified up to 10,000 feet above sea level
- CSA/ASME rated temperature and pressure relief valve

Warranty

- 3-Year limited tank and 1-year limited parts warranty

*See Commercial Warranty Certificate for complete information

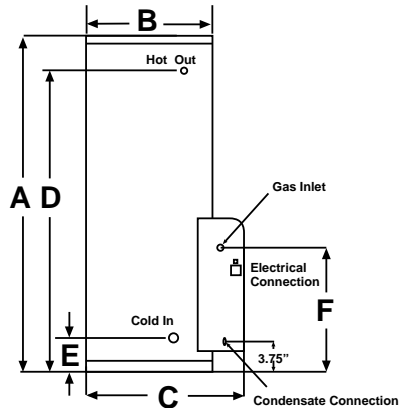

RECOVERY CAPACITIES							DIMENSIONAL INFORMATION (All dimensions shown in inches)									
MODEL NUMBER	GAL. CAP.	INPUT (BTU/h) NAT. & LP	THERMAL EFFIC.	TEMP. RISE – G.P.H.			A	B	C	D	E	F	VENT	WATER CONNECTS		APPROX. SHIP. WT. (LBS)
				40° F	100° F	140° F								INLET	OUTLET	
★ HE55-100*	55	100,000	95%	288	115	N/A	52	23-1/2	32	45	5	25-1/4	2*	1	1	175
★ HE55-130*	55	130,000	95%	374	150	N/A	52	23-1/2	32	45	5	25-1/4	2*	1	1	175
★ HE80-130*	80	130,000	95%	374	150	N/A	72	23-1/2	32	65	5	25-1/4	2*	1-1/2	1-1/2	235
★ HE119-130*	119	130,000	95%	374	150	N/A	73	27	36	66-3/4	6-3/4	28-7/8	2*	1-1/2	1-1/2	405
★ HE55-160	55	160,000	95%	461	184	132	52	23-1/2	32	45	5	25-1/4	3	1	1	175
★ HE80-160	80	160,000	95%	461	184	N/A	72	23-1/2	32	65	5	25-1/4	3	1-1/2	1-1/2	235
★ HE119-160	119	160,000	95%	461	184	N/A	73	27	36	66-3/4	6-3/4	28-7/8	3	1-1/2	1-1/2	405
★ HE55-199	55	199,000	95%	573	229	164	52	23-1/2	32	45	5	25-1/4	3	1	1	175
★ HE80-199	80	199,000	95%	573	229	N/A	72	23-1/2	32	65	5	25-1/4	3	1-1/2	1-1/2	235
★ HE119-199	119	199,000	95%	573	229	N/A	73	27	36	66-3/4	6-3/4	28-7/8	3	1-1/2	1-1/2	405

★ **ENERGY STAR® compliant model.**

The recovery rate is based on recovery efficiencies obtained in a UL certified laboratory. These models have been tested according to ANSI Z21.10.3 test procedures and exceed the thermal efficiency and standby loss requirements of ASHRAE (part of the Federally mandated Energy Policy Act - EPACT). These models also exceed the energy efficiency codes of all states including the California Energy Commission (CEC). All models are North Carolina Code compliant.

Use HEC prefix for Canadian models.

0" Clearance to combustibles on all AdvantagePlus units, however, a 24" control panel service clearance is recommended.

*Models with inputs of 100,000 BTU/h and 130,000 BTU/h are certified to vent with 2" schedule 40 PVC or CPVC pipe. (For Canadian installations, please use ULC-S636 PVC and CPVC pipe.)

The HE55-160 and HE55-199 Booster models are the only models equipped with a 180°F thermostat. Models with 180°F thermostats come standard with the Booster Installation Kit which includes all necessary components for an approved installation. Booster Installation Kit includes: Nibco Tee – 1" x 1" x 1/2" (2 pieces), Female Adapter – 1" (2 pieces),

Dial Thermometer (2 pieces), Expansion Tank – 4-1/2 gallon, Grundfos 3 Speed Pump with Check Valve, Nibco 1.2" x 12" Fitting Air Chamber, Vacuum Relief Valve, Pressure Gauge – 0-200 psi, Nibco Tee 712R – 1" x 1" x 3/4" (2 pieces), Nibco Tee 714RR – 1" x 1/2" x 1", Nibco Tee – 1" x 1/2" x 1" Copper, Reducing Coupling, Pressure Reducing Valve, Nibco Male Adapter – 1"



Universal™ Heavy Duty (G Series)

Features

- Meet or exceed ASHRAE minimum of 80%
- 98,000-399,900 BTU/h
- 35 to 100-Gallon capacities
- 180° F Maximum temperature setting
- Top-front-rear inlet/outlet water connections
- Short floor to vent heights, small jacket diameters
- Exclusive System Sentinel LED diagnostic system
- Patented multi-flue design
- Stainless steel burners with raised port design slide out for quick inspection and maintenance
- Low profile automatic flue damper
- Full-port, full-flow brass drain valve
- Direct spark-to-pilot ignition system
- Patented anode rods for long tank life
- Certified up to 5,000 feet above sea level for natural gas, 2,000 feet for LP; with altitude certification kit, up to 8,000 feet
- Low lead compliant
- Natural and LP models

Warranty

- 3-Year limited tank, upgradable to 5-years and 1-year limited parts warranty*

*See Commercial Warranty Certificate for complete information

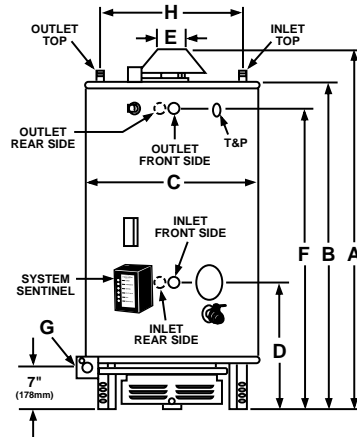
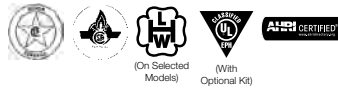

RECOVERY CAPACITIES							DIMENSIONAL INFORMATION (All dimensions shown in inches)												
MODEL NUMBER	GAL. CAP.	INPUT (BTU/h) NAT. & LP	THERMAL EFFIC.	TEMP. RISE – G.P.H.			A	B	C	D	E	F	G	H	WATER CONNECTS			APPROX. SHIP. WT. (LBS)	
				40° F	100° F	140° F									TOP	FRONT	REAR	STD.	ASME
G50-98	50	98,000	80%	238	95	68	62-3/4	57-1/8	22-1/2	22-5/8	5	50-1/2	1/2	15	1	1-1/2	1-1/2	270	N/A
G75-125	75	125,000	80%	303	121	87	65-1/2	61	26-1/4	25	5	56	3/4	20	1-1/2	1-1/2	1-1/2	480	N/A
G82-156	82	156,000	80%	378	151	108	68-13/16	64	26-1/4	25	6	58-5/8	3/4	20	1-1/2	1-1/2	1-1/2	490	N/A
G76-180	76	180,000	80%	436	175	125	68-13/16	64	26-1/4	25	6	58-5/8	3/4	20	1-1/2	1-1/2	1-1/2	540	N/A
G37-200	35	199,900	80%	485	194	138	49-1/4	43-3/8	26-1/4	25	6	37-5/8	3/4	20	1-1/2	1-1/2	1-1/2	405	N/A
G76-200	76	199,900	80%	485	194	138	68-13/16	64	26-1/4	25	6	58-5/8	3/4	20	1-1/2	1-1/2	1-1/2	540	N/A
G91-200	91	199,900	80%	485	194	138	76-5/16	71-13/16	26-1/4	30-5/8	6	66-3/8	3/4	20	1-1/2	1-1/2	1-1/2	600	N/A
G100-200(A)	100	199,900	80%	485	194	138	73-1/16	66-1/8	30-1/4	23-1/4	6	57-1/2	3/4	23	1-1/2	2	2	780	835
G72-250(A)	72	250,000	80%	606	242	173	71-1/16	64-1/2	26-1/4	25	6	58-5/8	3/4	20	1-1/2	1-1/2	1-1/2	590	630
G100-250(A)	100	250,000	80%	606	242	173	73-1/4	66-1/8	30-1/4	23-1/4	8	57-1/2	3/4	23	1-1/2	2	2	795	835
G100-270(A)	100	270,000	80%	654	262	187	73-7/8	66-1/8	30-1/4	23-1/4	8	57-1/2	3/4	23	1-1/2	2	2	805	845
G72-300(A)	72	300,000	80%	727	291	208	71	64-1/2	26-1/4	25	8	58-5/8	3/4	20	1-1/2	1-1/2	1-1/2	590	630
G85-300(A)	85	300,000	80%	727	291	208	78-7/16	72-5/16	26-1/4	30-5/8	8	66-3/8	3/4	20	1-1/2	1-1/2	1-1/2	640	680
G100-310(A)	100	310,000	80%	752	301	215	75	68-1/2	30-1/4	32-1/4	7	61-3/4	3/4	23	1-1/2	2	2	770	810
G65-360(A)	65	360,000	80%	873	349	249	70-11/16	64-1/2	26-1/4	25	8	58-5/8	3/4	n/a	n/a	1-1/2	1-1/2	640	680
G65-400(A)	65	399,900	80%	969	388	277	70-11/16	64-1/2	26-1/4	25	8	58-5/8	3/4	n/a	n/a	1-1/2	1-1/2	640	680
G85-400(A)	85	399,900	80%	969	388	277	78-13/16	72-5/16	26-1/4	30-5/8	10	66-3/8	3/4	20	1-1/2	1-1/2	1-1/2	640	680
G100-400(A)	100	399,900	80%	969	388	277	76	68-1/2	30-1/4	32-1/4	8	61-3/4	1*	23	1-1/2	2	2	770	810

Recovery ratings are based on thermal efficiencies obtained in a CSA certified laboratory. Thermal Efficiency in accordance with ANSI Z21.10.3 labeling requirements.

(A) Indicates available ASME Model. *3/4" for L.P. models. Increase height 3-5/8" for NSF models. All models require a 120V power source.

These models have been tested according to ANSI test procedures, and exceed the thermal efficiency and standby loss requirements of ASHRAE (Part of the Federally mandated Energy Policy Act (EPact)). Also exceeds energy efficiency codes of all states including California Energy Commission (CEC). All models are North Carolina Code compliant.



Universal™ Low NOx Heavy Duty (GN Series)

Features

- 80% Thermal efficiency
- 125,000-399,900 BTU/h
- 35 to 100-Gallon capacities
- 180° F Maximum temperature setting
- Top-front-rear inlet/outlet water connections
- Short floor to vent heights, small jacket diameters
- Exclusive System Sentinel LED diagnostic system
- Patented multi-flue design with proprietary steel formulation and two coats of porcelain enamel for a superior heat exchanger design
- Low profile automatic flue damper
- Full-port, full-flow brass drain valve
- Direct spark-to-pilot ignition system
- Patented anode rods for long tank life
- Low lead compliant
- Natural gas models

Low NOx Burner

- Power assist burner design incorporates stainless steel multi-port burner tubes for long term low NOx performance, less than 40 ng/J
- Sight glass allows for burner observation
- Blower guard provides protection against potential post-installation damage
- Low NOx models are certified up to 2,000 feet; high altitude certification for models GN76-200, GN91-200 and GN100-270 is 5,000 feet; model GN100-200(A) is 8,000 feet

Warranty

- 3-Year limited tank, upgradable to 5-years and 1-year limited parts warranty*

*See Commercial Warranty Certificate for complete information



(On Selected Models)

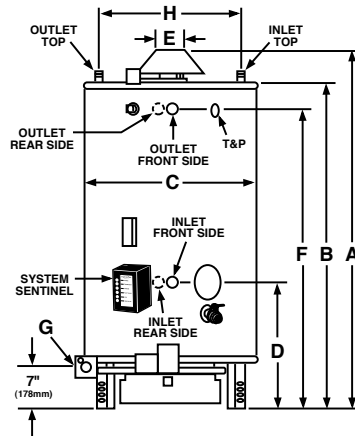

4000
PROCLUB
POINTS

ELITEXPRESS
48 HOUR
DELIVERY



RECOVERY CAPACITIES							DIMENSIONAL INFORMATION (All dimensions shown in inches)												
MODEL NUMBER	GAL. CAP.	INPUT (BTU/h) NAT.	THERMAL EFFIC.	TEMP. RISE – G.P.H.			A	B	C	D	E	F	G	H	WATER CONNECTS			APPROX. SHIP. WT. (LBS)	
				40° F	100° F	140° F									TOP	FRONT	REAR	STD.	ASME
GN75-125	75	125,000	80%	303	121	87	65-1/2	61	26-1/4	25	5	56	3/4	20	1-1/2	1-1/2	1-1/2	480	N/A
GN82-156	82	156,000	80%	378	151	108	68-13/16	64	26-1/4	25	6	58-5/8	3/4	20	1-1/2	1-1/2	1-1/2	490	N/A
GN37-200	35	199,900	80%	485	194	138	49-1/4	43-3/8	26-1/4	25	6	37-5/8	3/4	20	1-1/2	1-1/2	1-1/2	405	N/A
GN76-200	76	199,900	80%	485	194	138	68-13/16	64	26-1/4	25	6	58-5/8	3/4	20	1-1/2	1-1/2	1-1/2	540	N/A
GN91-200	91	199,900	80%	485	194	138	76-5/16	71-13/16	26-1/4	30-5/8	6	66-3/8	3/4	20	1-1/2	1-1/2	1-1/2	600	N/A
GN100-200(A)	100	199,900	80%	485	194	138	73-1/16	66-1/8	30-1/4	23-1/4	6	57-1/2	3/4	23	1-1/2	2	2	780	835
GN72-250(A)	72	250,000	80%	606	242	173	71-1/16	64-1/2	26-1/4	25	6	58-5/8	3/4	20	1-1/2	1-1/2	1-1/2	590	630
GN100-250(A)	100	250,000	80%	606	242	173	73-1/4	66-1/8	30-1/4	23-1/4	6	57-1/2	3/4	23	1-1/2	2	2	795	835
GN100-270(A)	100	270,000	80%	655	262	187	73-7/8	66-1/8	30-1/4	23-1/4	6	57-1/2	3/4	23	1-1/2	2	2	805	845
GN65-360(A)	65	360,000	80%	873	349	249	70-11/16	64-1/2	26-1/4	25	8	58-5/8	3/4	N/A	N/A	1-1/2	1-1/2	640	680
GN100-400(A)	100	399,900	80%	969	388	277	76	68-1/2	30-1/4	32-1/4	8	61-3/4	1	23	1-1/2	2	2	770	810

Recovery ratings are based on thermal efficiencies obtained in a CSA certified laboratory.

(A) Indicates available ASME model.

All models require a 120V /1.5 Amp power source.



Universal™ Ultra Low NOx Heavy Duty (GNU Series)

Features

- 80-82% Thermal efficiency
- 125,000-399,900 BTU/h
- 35 to 100-Gallon capacities
- 180° F Maximum temperature setting
- Top-front-rear inlet/outlet water connections
- Short floor to vent heights, small jacket diameters
- Exclusive System Sentinel LED diagnostic system
- Patented multi-flue design with proprietary steel formulation and two coats of porcelain enamel for a superior heat exchanger design
- Low profile automatic flue damper
- Full-port, full-flow brass drain valve
- Direct spark-to-pilot ignition system
- Patented anode rods for long tank life
- Low lead compliant
- Natural gas models

Ultra Low NOx Burner

- Power assist burner design incorporates stainless steel multi-port burner tubes for long term ultra low NOx performance, less than 14 ng/J
- Sight glass allows for burner observation
- Entire design is removable and it is highly resistant to the effects of negative air pressure common in modern commercial buildings
- Ultra low NOx base rail provides for better handling when moving and positioning unit
- GNU100-200(A) models are certified up to 5,200 feet above sea level. All other models are certified up to 2,000 feet

Warranty

- 3-Year limited tank, upgradable to 5-years and 1-year limited parts warranty*

*See Commercial Warranty Certificate for complete information

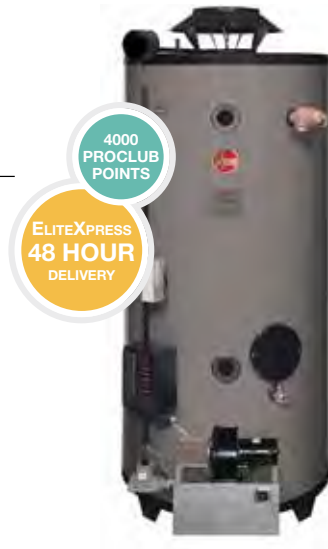
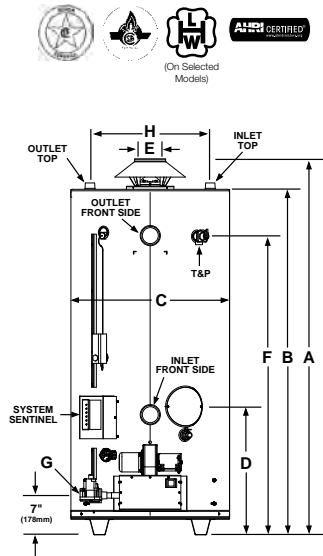

RECOVERY CAPACITIES							DIMENSIONAL INFORMATION (All dimensions shown in inches)												
MODEL NUMBER	GAL. CAP.	INPUT (BTU/h) NAT.	THERMAL EFFIC.	TEMP. RISE – G.P.H.			A	B	C	D	E	F	G	H	WATER CONNECTS			APPROX. SHIP. WT. (LBS)	
				40° F	100° F	140° F									TOP	FRONT	REAR	STD.	ASME
GNU75-125	75	125,000	80%	303	121	87	65-1/2	61	26-1/4	25	5	56	3/4	20	1-1/2	1-1/2	1-1/2	480	N/A
GNU82-156	82	156,000	80%	378	151	108	68-13/16	64	26-1/4	25	6	58-5/8	3/4	20	1-1/2	1-1/2	1-1/2	490	N/A
GNU37-200	35	199,900	82%	485	194	138	49-1/4	43-3/8	26-1/4	25	6	37-5/8	3/4	20	1-1/2	1-1/2	1-1/2	405	N/A
GNU76-200	76	199,900	80%	485	194	138	68-13/16	64	26-1/4	25	6	58-5/8	3/4	20	1-1/2	1-1/2	1-1/2	540	N/A
GNU91-200	91	199,900	82%	485	194	138	76-5/16	71-13/16	26-1/4	30-5/8	6	66-3/8	3/4	20	1-1/2	1-1/2	1-1/2	600	N/A
GNU100-200(A)	100	199,900	82%	485	194	138	73-1/16	66-1/8	30-1/4	23-1/4	6	57-1/2	3/4	23	1-1/2	2	2	780	835
GNU72-250(A)	72	250,000	80%	606	242	173	71-1/16	64-1/2	26-1/4	25	6	58-5/8	3/4	20	1-1/2	1-1/2	1-1/2	590	630
GNU100-250(A)	100	250,000	82%	606	242	173	73-1/4	66-1/8	30-1/4	23-1/4	6	57-1/2	3/4	23	1-1/2	2	2	795	835
GNU100-270(A)	100	270,000	82%	655	262	187	73-7/8	66-1/8	30-1/4	23-1/4	6	57-1/2	3/4	23	1-1/2	2	2	805	845
GNU65-360(A)	65	360,000	80%	873	349	249	70-11/16	64-1/2	26-1/4	25	8	58-5/8	3/4	N/A	N/A	1-1/2	1-1/2	640	680
GNU100-400(A)	100	399,900	80%	969	388	277	76	68-1/2	30-1/4	32-1/4	8	61-3/4	1	23	1-1/2	2	2	770	810

Recovery ratings are based on thermal efficiencies obtained in a CSA certified laboratory.

(A) Indicates available ASME model.

All models require a 120V /1.5 Amp power source.



Universal™ Induced Draft Heavy Duty (GD Series)

Features

- 80% Thermal efficiency
- 250,000, 270,000, 310,000 and 360,000 BTU/h
- 100-Gallon capacity
- 180° F Maximum temperature setting
- Top-front-rear inlet/outlet water connections
- Short floor to vent heights, small jacket diameters
- Exclusive System Sentinel LED diagnostic system
- Patented multi-flue design with proprietary steel formulation and two coats of porcelain enamel for a superior heat exchanger design
- Full-port, full-flow brass drain valve
- Direct spark-to-pilot ignition system
- Patented anode rods for long tank life
- CSA/ASME rated temperature and pressure relief valve
- Low lead compliant
- Natural and LP models

Factory Installed Draft Inducer

- Provides an induced draft allowing higher BTUs to be vented through 6-inch vent

6-Inch Category 1 Appliance

- Allows for easy upgrade or retrofit of existing applications

Warranty

- 3-Year limited tank, upgradable to 5-years and 1-year limited parts warranty*

*See Commercial Warranty Certificate for complete information

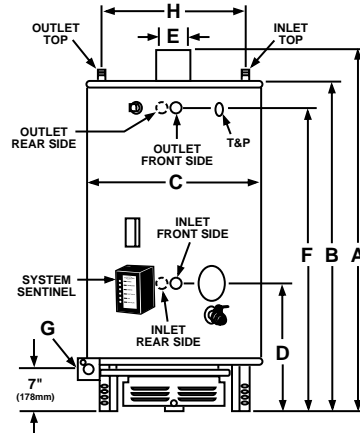
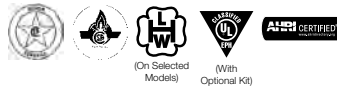

Gas Tank - Type

RECOVERY CAPACITIES							DIMENSIONAL INFORMATION (All dimensions shown in inches)												
MODEL NUMBER	GAL. CAP.	INPUT (BTU/h) NAT. & LP	THERMAL EFFIC.	TEMP. RISE – G.P.H.			A	B	C	D	E	F	G	H	WATER CONNECTS			APPROX. SHIP. WT. (LBS)	
				40° F	100° F	140° F									TOP	FRONT	REAR	STD.	ASME
GD100-250(A)	100	250,000	80%	606	242	173	73-1/2	66-3/4	30-1/4	23-1/4	6	57-1/2	3/4	23	1-1/2	2	2	795	835
GD100-270(A)	100	270,000	80%	665	262	187	73-1/2	66-3/4	30-1/4	23-1/4	6	57-1/2	3/4	23	1-1/2	2	2	795	835
GD100-310(A)	100	310,000	80%	752	301	215	73-1/2	66-3/4	30-1/4	23-1/4	6	57-1/2	3/4	23	1-1/2	2	2	795	835
GD100-360(A)	100	360,000	80%	873	349	249	73-1/2	66-3/4	30-1/4	23-1/4	6	57-1/2	3/4	23	1-1/2	2	2	795	835

Recovery ratings are based on thermal efficiencies obtained in a CSA certified laboratory. These models have been tested according to ANSI Z21.10.3 test procedures, and exceed the thermal efficiency and standby loss requirements of ASHRAE (Part of the Federally mandated Energy Policy Act (EPact)). Also exceeds energy efficiency codes of all states.

(A) Indicates available ASME model.

All models require a 120V /3 Amp power source.



Xtreme™ Heavy Duty (GX Series)

Features

- 80% Thermal efficiency
- 500,000-715,000 BTU/h
- 90-Gallon capacity
- 180° F Maximum temperature setting
- Exclusive System Sentinel LED diagnostic system with glowing LED lights verifies system operation sequence by sequence
- Patented multi-flue design with proprietary steel formulation and two coats of porcelain enamel for a superior heat exchanger design
- Low profile automatic flue damper
- Five premix burners mounted into a metal face plate and sealed with a Viton gasket. Patented quick release manifold for easier service
- Direct spark-to-pilot ignition system
- Precision round premix burners formed from chromium stainless steel
- Full-port, full-flow brass drain valve
- Patented magnesium anode rods for long tank life
- Standard natural and LP models are certified up to 2,000 feet above sea level; 8,000 feet for high altitude models
- Low lead compliant
- Natural and LP models

Warranty

- 3-Year limited tank, upgradable to 5-years and 1-year limited parts warranty*

*See Commercial Warranty Certificate for complete information

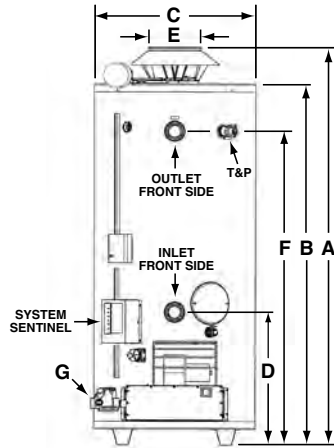
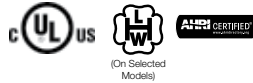

RECOVERY CAPACITIES							DIMENSIONAL INFORMATION (All dimensions shown in inches)										
MODEL NUMBER	GAL. CAP.	INPUT (BTU/h) NAT. & LP	THERMAL EFFIC.	TEMP. RISE – G.P.H.			A	B	C	D	E	F	G	WATER CONNECTS		APPROX. SHIP. WT. (LBS)	
				40° F	100° F	140° F								FRONT	REAR	STD.	ASME
GX90-550(A)	90	550,000 NAT	80%	1333	533	381	74.5	68	30	25	10	59	1	2	2	905	945
GX90-640(A)	90	640,000 NAT	80%	1551	621	443	74.5	68	30	25	10	59	1	2	2	905	945
GX90-715(A)	90	715,000 NAT	80%	1733	693	495	74.5	68	30	25	10	59	1	2	2	905	945
GX90-500(A) LP	90	500,000 LP	80%	1212	485	346	74.5	68	30	25	10	59	1	2	2	905	945
GX90-600(A) LP	90	600,000 LP	80%	1455	582	416	74.5	68	30	25	10	59	1	2	2	905	945
GX90-680(A) LP	90	680,000 LP	80%	1649	659	471	74.5	68	30	25	10	59	1	2	2	905	945

Recovery ratings are based on thermal efficiencies obtained in a CSA certified laboratory. These models have been tested according to ANSI Z21.10.3 test procedures, and exceed the thermal efficiency and standby loss requirements of ASHRAE (Part of the Federally mandated Energy Policy Act (EPact)). Also exceeds energy efficiency codes of all states.

(A) Indicates available ASME model.

All models require a 120V power source.



VentMaster® Heavy Duty Power Direct Vent (GP Series)

Features

- Meets or exceeds a minimum of 80% thermal efficiency (non-condensing)
- 199,900 and 250,000 BTU/h
- 100-Gallon capacity
- 180° F Maximum temperature setting
- Exclusive System Sentinel LED diagnostic system
- Patented multi-flue design with proprietary steel formulation and two coats of porcelain enamel
- 120 Volt integral automatic blower assists quietly discharges combustion gases
- Installs easier with less costly 3" or 4" Schedule 40 PVC pipe; no masonry or metal vent chimney is required
- Base rail design provides better handling when moving unit
- Full-port, full-flow brass drain valve
- Direct spark-to-pilot ignition system
- Hand-hole cleanout for easy removal of sediment deposits
- CSA/ASME rated temperature and pressure relief valve
- Standard models certified to 2,000 feet above sea level; high altitude models certified to 8,000 feet above sea level

- Low lead compliant
- Natural and LP models

Gas Control System

- Fully adjustable thermostat from 100° F to 180° F
- 24 Volt combination gas valve includes main gas pressure regulation and an on-off manual valve

Warranty

- 3-Year limited tank, upgradable to 5-years and 1-year limited parts warranty*

*See Commercial Warranty Certificate for complete information



(On Selected Models)

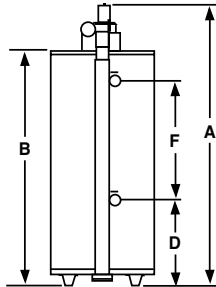
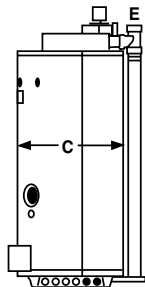

RECOVERY CAPACITIES							DIMENSIONAL INFORMATION (All dimensions shown in inches)									
MODEL NUMBER	GAL. CAP.	INPUT (BTU/h) NAT. & LP	THERMAL EFFIC.	TEMP. RISE – G.P.H.			A	B	C	D	E	F	GAS VALVE	WATER CONNECTS		APPROX. SHIP. WT. (LBS)
				40° F	100° F	140° F								INLET	OUTLET	
GP100-200	100	199,900	80%	485	194	138	81-3/4	68-1/4	30-1/4	24-3/4	3	59	3/4	2	2	860
GP100-250(A)	100	250,000	80%	606	242	173	81-3/4	68-1/4	30-1/4	24-3/4	4	59	3/4	2	2	860

Recovery ratings are based on thermal efficiencies obtained in a CSA certified laboratory. These models have been tested according to ANSI Z21.10.3 test procedures, and exceed the thermal efficiency and standby loss requirements of ASHRAE (Part of the Federally mandated Energy Policy Act (EPact)). Also exceeds energy efficiency codes of all states.

(A) Indicates available ASME model.



Hot Water Supply Heaters Heavy Duty (GBC Series)

Features

- 82% Thermal efficiency
- 136,000-1,826,000 BTU/h
- 180° F Maximum temperature setting
- Indoor and outdoor models
- For use with or without a circulating pump
- Spark-to-pilot (IID) system for minimal heat loss
- Glasslined cast iron headers handle any aggressive water condition
- Low lead compliant
- Natural and LP models

Reliable Heat Exchanger Design

- Copper heat exchanger
- Single bank, straight-through design
- Floating return header is immune to thermal shock

Energy Saving Pump Control

- Allows the operator to set the desired time for the pump to run after the water heater shuts off
- Water heater pump is programmed to continue running for an optimum period of time in order to absorb the residual heat

Warranty

- 5-Year limited heat exchanger warranty*

*See Commercial Warranty Certificate for complete information

MBTUH PROPANE GAS†	
MODEL SIZE	MULTIPLIER
136-399	Same as natural gas
512-825	.94
926-1826	.92 Indoor
	.955 Outdoor (input)
	.92 Outdoor (output)

†Multiplier x Nat. MBTUH = Pro. MBTUH

ELECTRICAL RATINGS	
MODEL SIZE	WITH PUMP
136-399	3.7 amps @ 120V (1/8 hp pump)
331-399	3.6 amps @ 120V (1/6 hp pump)
512-1826	7.2 amps @ 120V (1/2 hp pump)



SPECIFICATIONS AND DIMENSIONAL INFORMATION																	
MODEL NUMBER		STYLE		MBTUH NATURAL GAS (X 1000)				TEMPERATURE RISE – GALLONS PER HOUR			DIMENSIONS (INCHES)					SHIPPING WEIGHT††	
WITH-OUT PUMP	WITH PUMP	IN-DOOR	OUT-DOOR	(INDOOR)		(OUTDOOR)		40°F	100°F	140°F	WIDTH	HEIGHT OVERALL	JACKET HEIGHT	GAS CONN.	FLUE DIA.	(INDOOR)	(OUTDOOR)
				INPUT	OUTPUT	INPUT	OUTPUT										
GBC136*	GBCP136*	•	•	136.0	112.0	136.0	112.0	330	132	94	14-1/4	45	30-1/8	1/2	6	195	195
GBC186	GBCP186	•	•	181.0	148.0	181.0	148.0	445	178	127	18-1/4	40	38	3/4	6	191	200
GBC264	GBCP264	•	•	264.0	216.0	264.0	216.0	640	256	183	22-3/8	40	38	3/4	7	214	220
GBC331	GBCP331	•	•	334.0	274.0	334.0	274.0	822	328	235	25-3/4	40	38	3/4	8	234	240
GBC399	GBCP399	•	•	399.0	327.0	399.0	327.0	967	387	276	29-1/4	40	38	3/4	9	253	260
GBC512	GBCP512	•	•	511.5	419.4	511.5	419.4	1240	496	354	32-3/4	57	33	1	10	510	535
GBC627	GBCP627	•	•	627.0	514.1	627.0	514.1	1520	608	434	37-1/2	57	33	1	12	520	545
GBC726	GBCP726	•	•	726.0	595.4	726.0	595.4	1760	704	503	41-5/8	57	33	1	12	630	685
GBC825	GBCP825	•	•	825.0	676.5	825.0	676.5	2000	800	571	45-3/4	57	33	1	14	660	720
GBC926	GBCP926	–	•	–	–	926.0	759.3	3345	898	641	52-3/8	–	–	1	–	–	790
GBC962	GBCP962	•	–	961.7	788.6	–	–	2331	933	665	52-3/8	68-3/4	33-1/2	1	14	760	–
GBC1083	GBCP1083	–	•	–	–	1083.0	888.1	2625	1050	750	59-1/4	–	–	1	–	–	850
GBC1125	GBCP1125	•	–	1124.7	922.2	–	–	2727	1091	779	59-1/4	74-1/2	33-1/2	1	16	800	–
GBC1178	GBCP1178	–	•	–	–	1178.0	966.0	2856	1142	816	63-5/8	–	–	1	–	–	910
GBC1223	GBCP1223	•	–	1222.5	1002.4	–	–	2964	1185	847	63-5/8	74-1/2	33-1/2	1	16	860	–
GBC1287	GBCP1287	–	•	–	–	1287.0	1055.3	3120	1248	891	68-5/8	–	–	1-1/4	–	–	975
GBC1337	GBCP1337	•	–	1336.6	1096.0	–	–	3240	1296	926	68-5/8	76-1/2	33-1/2	1-1/4	18	930	–
GBC1413	GBCP1413	–	•	–	–	1413.0	1158.7	3425	1370	979	74-7/8	–	–	1-1/4	–	–	1065
GBC1467	GBCP1467	•	–	1467.0	1202.9	–	–	3556	1423	1016	74-7/8	76-1/2	33-1/2	1-1/4	18	1000	–
GBC1570	GBCP1570	–	•	–	–	1570.0	1287.4	3806	1522	1087	81-1/8	–	–	1-1/4	–	–	1120
GBC1630	GBCP1630	•	–	1630.0	1336.5	–	–	3952	1581	1129	81-1/8	79-1/2	36-1/2	1-1/4	18	1040	–
GBC1758	GBCP1758	–	•	–	–	1758.0	1441.6	4262	1705	1218	89-3/8	–	–	1-1/4	–	–	1150
GBC1826	GBCP1826	•	–	1825.6	1496.9	–	–	4426	1770	1264	89-3/8	81-1/2	36-1/2	1-1/4	20	1090	–

††Subtract 55 lbs. when ordering GBC models. *Equipped with bronze headers, all other models have glasslined cast iron headers.
GBC – cast iron headers. GBB – bronze headers. Add N after model number for Low NOx configuration on 186-399 models.



Medium Duty (G Series)

Features

- 80% thermal efficiency on 75 - 100-gallon models
- .60 EF on 48-gallon models
- 54,000-80,000 BTU/h
- 48, 75, 98 and 100-Gallon capacities
- 180° F maximum temperature setting for G75-75N model; all other models 160° F Maximum temperature setting
- Proprietary steel formulation with a unique coat of high temperature porcelain enamel maximizes corrosion resistance resulting in a superior tank design
- Magnesium anode rods ensure corrosion resistance for a long tank life
- Rigid foam insulation provides superior insulating qualities, improves efficiency and reduces operating costs
- Factory installed CSA/ASME rated temperature and pressure relief valve
- Factory installed full-port, full-flow brass drain valve
- Some models are certified for applications up to 8,500 feet above sea level. Please consult factory for certification requirements
- Low lead compliant

Warranty

- 3-Year limited tank, upgradable to 5-years and 1-year limited parts warranty*

*See Commercial Warranty Certificate for complete information

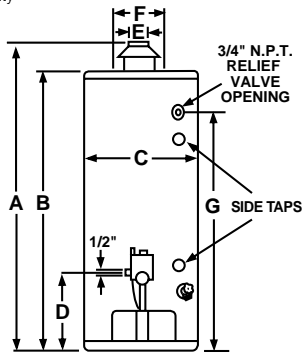

G50-65, G75-75 & G100-65
Side taps on 48, 75 & 98 gallon models only

G50-65
water connections are 3/4" NPT

G75-75 & G100-65LP
water connections are 1" NPT

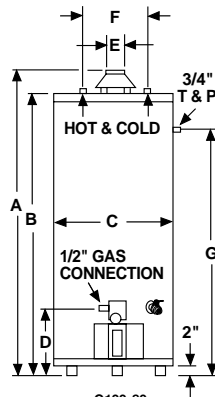

G100-80
water connections are 1" NPT

4000
PROCLUB
POINTS

ELITEXPRESS
48 HOUR
DELIVERY



RECOVERY CAPACITIES								DIMENSIONAL INFORMATION (All dimensions shown in inches)										
MODEL NUMBER	GAL. CAP.	INPUT (BTU/h) NAT. & LP	THERMAL EFFIC.	ENERGY FACTOR	TEMP. RISE – G.P.H.			A	B	C	D	E	F	G	CLEARANCE TO COMBUST.			APPROX. SHIP. WT. (LBS)
					40° F	100° F	130° F								SIDE	FRONT	TOP	
G50-60N†*	48	60,000	–	0.60	107	43	33	61-3/4	58-1/2	21-3/4	14	4	11	51-3/4	0	3	12	150
G50-54LP*	48	54,000	–	0.60	86	34	26	61-3/4	58-1/2	21-3/4	14	4	11	51-3/4	0	3	12	150
G75-75N-3†*	75	75,100	80%	–	182	73	56	64	60	26-1/4	13-1/4	4	11	53-1/4	1	3	12	320
G75-76LP*	75	75,100	80%	–	182	73	56	64	60	26-1/4	13-1/4	4	11	53-1/4	1	3	12	320
G100-80	100	80,000	80%	–	194	78	60	69-5/8	65-3/4	28-1/4	11	4	15	57-13/16	1	Alcove	12	410
G100-80N†	100	76,000	80%	–	184	74	57	69-5/8	65-3/4	28-1/4	11	4	15	57-13/16	1	Alcove	12	410
G100-76LP*	98	75,100	80%	–	182	73	56	67-7/8	64	27-1/4	14-7/8	4	11	57-3/16	1	3	12	350

Recovery ratings are based on thermal efficiencies obtained in a CSA certified laboratory.

†Meets 40ng/J NOx requirements.

*FVIR Compliant



Medium Duty Ultra Low NOx (G-UN Series)

Features

- 80% thermal efficiency
- 75,100 BTU/h
- 75 and 98-Gallon capacities
- 180° F Maximum temperature setting
- Power assist burner design incorporates stainless steel multi-port burner tubes for long term ultra low NOx performance, less than 14 ng/J
- Sight glass allows for burner observation
- Burner design is removable and highly resistant to the effects of negative air pressure
- Most standard models certified to 7,700 feet above sea level; high altitude kits available for up to 10,200 feet. See spec sheet for exceptions and variants
- Side water connections for space saving applications
- Durable silicon nitride ignitor (HSI)
- Low lead compliant

Warranty

- 3-Year limited tank, upgradable to 5-years and 1-year limited parts warranty*

*See Commercial Warranty Certificate for complete information

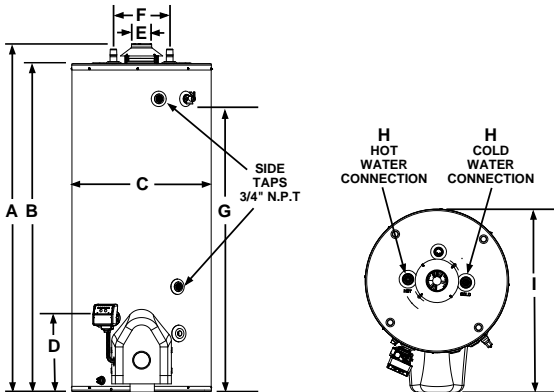

RECOVERY CAPACITIES							DIMENSIONAL INFORMATION (All dimensions shown in inches)									
MODEL NUMBER	GAL. CAP.	INPUT (BTU/h) NAT.	THERMAL EFFIC.	TEMP. RISE – G.P.H.			A	B	C	D	E	F	G	H	I	APPROX. SHIP. WT. (LBS)
				40° F	100° F	130° F										
G75UN	75	75,100	80%	182	73	56	64-1/8	60-1/4	26-1/4	14-1/4	4	11	52-1/4	1	33-3/4	300
G100UN	98	75,100	80%	182	73	56	67-7/8	64	27-1/8	14-1/4	4	11	56-1/8	1	34-3/4	370



Power Vent Medium Duty (GPV Series)

Features

- 80% Thermal efficiency
- 75,100 BTU/h
- 75-Gallon capacity
- 160° F Maximum temperature setting
- Superior tank design features proprietary steel formulation with a unique coat of high temperature porcelain enamel to maximize corrosion resistance
- FVIR compliant, maintenance free with no filters to clean
- Flammable vapor detection sensor disables the heater in the presence of flammable vapor accumulation
- Integrated self-diagnostic system
- Integral automatic powered blower assists quietly bringing in combustion air and discharging combustion gases
- Environmentally friendly burner is 40 ng/J NOx compliant
- Patented magnesium anode rod design with resistor protects the tank from corrosion
- Hot surface ignition (HSI) for less fuel consumption versus a standing pilot
- Self-cleaning
- Full-port, full-flow brass drain valve

- CSA/ASME rated temperature and pressure relief valve
- Certified up to 7,700 feet above sea level
- Low lead compliant
- Natural and LP models

Easier, Less Costly Venting

- Installs with PVC, ABS, or CPVC vent options with vertical or horizontal termination
- Side connections available for ease of installation and flexibility
- Maximum vent length is 95 equivalent feet using 4" PVC
- Vents up to 35 equivalent feet using 3" PVC pipe

Warranty

- 3-Year limited tank, upgradable to 5-years and 1-year limited parts warranty*

*See Commercial Warranty Certificate for complete information

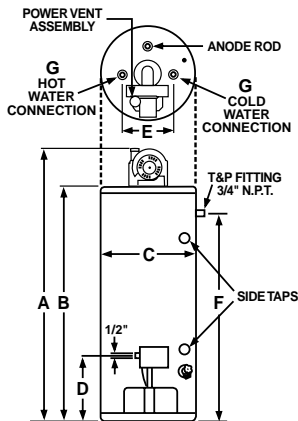

RECOVERY CAPACITIES							DIMENSIONAL INFORMATION (All dimensions shown in inches)							
MODEL NUMBER	GAL. CAP.	INPUT (BTU/h) NAT. & LP	THERMAL EFFIC.	TEMP. RISE – G.P.H.			A	B	C	D	E	F	G	APPROX. SHIP. WT. (LBS)
				40° F	100° F	120° F								
GPV75-76FV-2	75	75,100	80%	182	73	61	71-7/8	60-1/8	26-1/4	14-3/4	11	53-1/4	1	330
GPV75-76PFV-2	75	75,100	80%	182	73	61	71-7/8	60-1/8	26-1/4	14-3/4	11	53-1/4	1	330

Maximum and Minimum Vent Lengths for 3" and 4" Vents

FROM SEA LEVEL THROUGH 2,000 FEET ABOVE SEA LEVEL				
MODEL	VENT SYSTEM DIAMETER	MIN. ALLOWED EQUIVALENT VENT LENGTHS (EACH PIPE RUN)	MAX. ALLOWED EQUIVALENT VENT LENGTHS (EACH PIPE RUN)	VENT SYSTEM TERMINATION(S)
75-Gallon	3 Inches	10 Feet	50 Feet	90° Elbow
	4 Inches	10 Feet	100 Feet	90° Elbow

For the 3" and 4" vent, one 90° elbow is approximately equal to 5 feet of pipe.
One 45° elbow is approximately equal to 2.5 feet of pipe.

NOTICE: The mixing of 3" and 4" vent pipe is not recommended. If 4" pipe is used, a 3" to 4" reducer fitting is recommended at the rubber coupling.

This water heater is supplied with a 3" Schedule 40 PVC 90° vent terminal. When venting with 4" pipe, a Schedule 40 PVC 90° vent terminal must be used. Screens for both 3" and 4" vent terminals have been included.



Power Direct Vent Medium Duty (GPDV Series)

Features

- Meets or exceeds a minimum of 80% thermal efficiency (non-condensing) on 75-gallon models
- .62 EF on 50-gallon models
- 47,000-75,100 BTU/h
- 50 and 75-Gallon capacities
- 160° F Maximum temperature setting for 50-gallon models and 180° F for 75-gallon models
- Sealed combustion
- Flammable vapor detection sensor disables the heater in the presence of flammable vapor accumulation
- Integrated self-diagnostic system
- Integral automatic powered blower assists quietly bringing in combustion air and discharging combustion gases
- Environmentally friendly burner is 40 ng/J NOx compliant
- Patented anode rod design with resistor protects tank from corrosion
- Hot surface ignition (HSI)
- Self-cleaning
- CSA/ASME rated temperature and pressure relief valve

- Certified up to 7,700 or 10,200 feet above sea level, refer to venting chart on next page
- Low lead compliant
- Natural and LP models

Easier, Less Costly Venting

- Installs with PVC, ABS, or CPVC vent options with vertical or horizontal termination
- Side connections are available for ease of installation and flexibility
- Maximum vent length is 100 equivalent feet using 4" vent pipe and 50 equivalent feet using 3" vent pipe

Warranty

- 3-Year limited tank, upgradable to 5-years and 1-year limited parts warranty*

*See Commercial Warranty Certificate for complete information

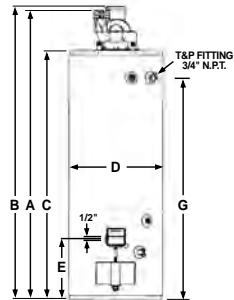
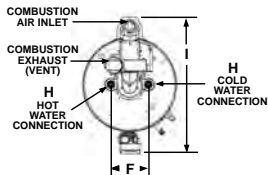

RECOVERY CAPACITIES					DIMENSIONAL INFORMATION (All dimensions shown in inches)												
MODEL NUMBER	GAL. CAP.	INPUT (BTU/h) NAT. & LP	THERMAL EFFIC.	ENERGY FACTOR	TEMP. RISE – G.P.H.			A	B	C	D	E	F	G	H	I	APPROX. SHIP. WT. (LBS)
					40° F	100° F	140° F										
GPDV50-65	50	65,000	–	0.62	148	59	42	67-5/8	68-3/8	59-3/8	21-3/4	14	8	52-3/4	3/4	31-1/2	210
GPDV50-65LP	50	65,000	–	0.62	107	43	31	67-5/8	68-3/8	59-3/8	21-3/4	14	8	52-3/4	3/4	31-1/2	210
GPDV75-75	75	75,100	80%	–	171	68	49	70-3/8	71-1/4	60-1/2	26-1/2	15	11	53	1	36-3/4	325
GPDV75-76LP	75	75,100	80%	–	171	68	49	70-3/8	71-1/4	60-1/2	26-1/2	15	11	53	1	36-3/4	325

Air-Inlet and Venting Information

MODEL NUMBER	VENT & COMBUSTION AIR-INLET SYSTEM DIAMETER (INCHES)				MIN. ALLOWED EQUIVALENT VENT & COMBUSTION AIR-INLET LENGTHS – EACH PIPE RUN (FT.)				MAX. ALLOWED EQUIVALENT VENT & COMBUSTION AIR-INLET LENGTHS – EACH PIPE RUN (FT.)				VENT AND COMBUSTION AIR-INLET SYSTEM TERMINATION(S)	
	SEA LEVEL – 2,000 FT. ABOVE S.L.	3,001 FT. – 5,999 FT. ABOVE S.L.	6,000 FT. – 7,700 FT. ABOVE S.L.	7,701 FT. – 10,200 FT. ABOVE S.L.	SEA LEVEL – 2,000 FT. ABOVE S.L.	3,001 FT. – 5,999 FT. ABOVE S.L.	6,000 FT. – 7,700 FT. ABOVE S.L.	7,701 FT. – 10,200 FT. ABOVE S.L.	SEA LEVEL – 2,000 FT. ABOVE S.L.	3,001 FT. – 5,999 FT. ABOVE S.L.	6,000 FT. – 7,700 FT. ABOVE S.L.	7,701 FT. – 10,200 FT. ABOVE S.L.		
GPDV50-65	3	3	3	3	7	7	7	7	50	50	50	25	90° Elbows	–
	3	3	3	3	7	7	7	7	40	40	40	20	–	Concentric*
	4	4	4	4	7	7	7	7	100	100	100	100	90° Elbows	–
GPDV75-75	3	3	–	–	8	8	–	–	50	25	–	–	90° Elbows	–
	3	3	–	–	8	8	–	–	40	20	–	–	–	Concentric*
	4	4	4	–	8	8	8	–	100	100	50	–	90° Elbows	–

• One 90° elbow is approximately equivalent to 5 feet of pipe. One 45° elbow is approximately equivalent to 2.5 feet of pipe.

* Use only Rheem 3 inch concentric termination.



Power Vent Kits

Features & Benefits

- Inputs: use with inputs from 98,000 – 400,000 BTU/h
- Use with natural gas or LP
- Vent Length: use for vent lengths up to a maximum of 50 feet including the vent terminal
- Vent terminal can be installed through combustible or non-combustible surfaces – heat shield is provided
- Venter can be connected to a vent termination on an exterior wall
- Vibration isolators are supplied to provide quiet operation
- Complete with mounting hardware
- Venter is pre-wired with 40 feet of #18-4 copper wire (24 volt)
- Power vent kits manufactured by Tjernlund Products, Inc. are tested and certified by CSA for use on these Rheem commercial gas water heaters (not for use with GN, GP, and GX models)

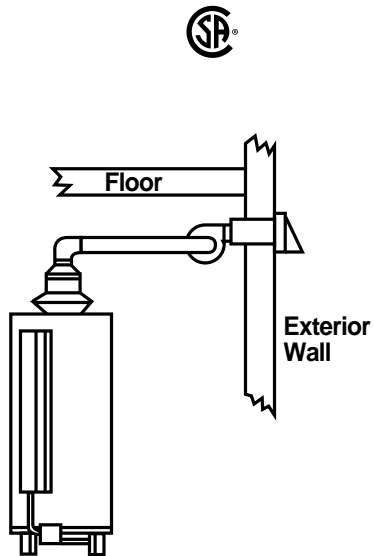

MODEL	VENT KIT	PART NO.	DRAFT HOOD OUTLET	VENT SIZE	VENT ADAPTER*
G50-98	PV Kit 4	AP11646	5"	4"	5" x 4"
G75-125	PV Kit 4	AP11646	5"	4"	5" x 4"
G82-156	PV Kit 4	AP11646	6"	4"	6" x 4"
G76-180	PV Kit 4	AP11646	6"	4"	6" x 4"
G37-200	PV Kit 5	AP11645	6"	6"	Not Req.
G76-200	PV Kit 5	AP11645	6"	6"	Not Req.
G91-200	PV Kit 5	AP11645	6"	6"	Not Req.
G100-200(A)	PV Kit 5	AP11645	6"	6"	Not Req.
G72-250(A)	PV Kit 5	AP11645	6"	6"	Not Req.
G100-250(A)	PV Kit 5	AP11645	8"	6"	8" x 6"
G100-270(A)	PV Kit 5	AP11645	8"	6"	8" x 6"
G72-300(A)	PV Kit 5	AP11645	8"	6"	8" x 6"
G85-300(A)	PV Kit 5	AP11645	8"	6"	8" x 6"
G100-310(A)	PV Kit 5	AP11645	7"	6"	7" x 6"
G65-360(A)	PV Kit 5	AP11645	8"	6"	8" x 6"
G65-400(A)	PV Kit 5	AP11645	8"	6"	8" x 6"
G85-400(A)	PV Kit 5	AP11645	10"	6"	10" x 6"

*Note: Vent Pipe and Vent Adapter are NOT included.
PVC Venting not for use with Power Vent kits listed above.

Power Vent Kit Dimensions

KIT#	MOTOR WATTS	MOTOR AMPS	MAX VENT	HEIGHT (H)	WIDTH (W)	DEPTH (D)	INLET OUTLET
4	95	1.26	50 ft	7-7/8"	11"	7"	4"
5	170	1.51	50 ft	9-1/4"	11-5/8"	8-5/8"	6"

Note: Max Vent Length based on total length of straight vent pipe plus 10 feet for each 90 degree elbow and 5 feet for each 45 degree elbow.

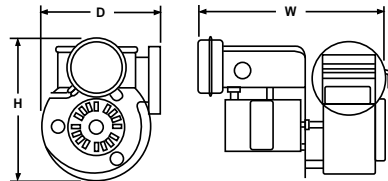

Vent Terminal Dimensions

KIT#	A	B	C	ROUGH IN DIMENSION
4	9"	9-1/2"	7" Sq.	8" Sq.
5	10-1/8"	9-1/2"	8-1/2" Dia.	9" Dia.

Note: Max Vent Length based on total length of straight vent pipe plus 10 feet for each 90 degree elbow and 5 feet for each 45 degree elbow.

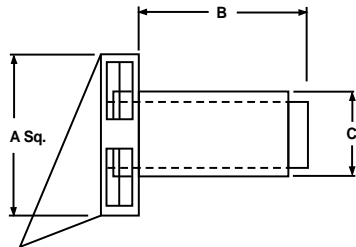

For technical assistance, please call the Tjernlund Help Line at 1-800-255-4208.



Commercial Condensing Tankless

Commercial Tankless models have all the features of Rheem's residential Tankless lineup **PLUS** 185°F built-in max temperature, common venting¹ and room air intake configurations, and built-in manifold options

Features

- Creates system redundancy to reduce or eliminate business downtime
- Models with built-in manifold control feature a factory installed translator, allowing up to 20 units to be connected in a daisy-chain via included cable
- **Common Vent** up to ten units with the Rheem polypropylene Header Kits, reducing outer wall penetrations
- Polypropylene stabilized (PPs) venting meets UL-1738 and ULC-S636 certifications
- Service Valves included
- Service Notifications – alerts when service is needed
- Built-In Condensate Neutralizer for safe disposal of condensate
- **Exclusive! Overheat Film Wrap** – detects if the heat exchanger overheats and shuts the system down to prevent damage
- **WiFi Enabled** – Models from 2010 to present can connect to EcoNet mobile app via Tankless EcoNet Accessory Kit (REWRA630TWH)

Warranty

- 5-Year heat exchanger, 5-year parts and 1-year labor limited warranty*

*See Commercial Warranty Certificate for complete information

EZ-Rack™ Kit

RTG20304

- Mounts easily to a wall or free standing
- One rack can mount 2 units in a back-to-back free standing configuration
- Expands with additional kits to hold any number of units
- Assembles easily on the jobsite in under 10 minutes
- Indoor / Outdoor use



¹Natural gas models only for common venting



LEED Points – 2

Commercial Tankless Models



RTGH-C95DVL

RTGH-C95XL

Commercial Tankless Models with Manifold Control



RTGH-CM95DVL

RTGH-CM95XL

DESCRIPTION				FEATURES						UNIT DIMENSIONS (SHOWN IN INCHES)					ENERGY INFO.	
MODEL NUMBER	GAS INPUT BTU/H	TYPE	FUEL TYPE	TEMP. RANGE	MIN. FLOW GPM	MIN. ACTIVATION GPM	GPM @ 77° RISE MAX.	GPM @ 45° RISE MAX.	MAX. GPM	CONNECTION		HEIGHT	WIDTH	DEPTH	SHIP WEIGHT (LBS.)	THERMAL EFFICIENCY
										WATER	GAS					
Commercial Tankless																
★ RTGH-C95DVLN	11,000-199,900	Indoor Direct Vent	Nat. Gas	85° to 185° F	0.26	0.40	5.0	8.5	9.5	3/4	3/4	27-1/2	18-1/2	9-3/4	82	96%
★ RTGH-C95DVLP	11,000-199,900	Indoor Direct Vent	Propane	85° to 185° F	0.26	0.40	5.0	8.5	9.5	3/4	3/4	27-1/2	18-1/2	9-3/4	82	95%
★ RTGH-C95XLN	11,000-199,900	Outdoor	Nat. Gas	85° to 185° F	0.26	0.40	5.0	8.5	9.5	3/4	3/4	27-1/2	18-1/2	9-3/4	82	96%
★ RTGH-C95XLP	11,000-199,900	Outdoor	Propane	85° to 185° F	0.26	0.40	5.0	8.5	9.5	3/4	3/4	27-1/2	18-1/2	9-3/4	82	95%
Manifold Ready Commercial Tankless																
★ RTGH-CM95DVLN	11,000-199,900	Indoor Direct Vent	Nat. Gas	85° to 185° F	0.26	0.40	5.0	8.5	9.5	3/4	3/4	27-1/2	18-1/2	9-3/4	82	96%
★ RTGH-CM95DVLP	11,000-199,900	Indoor Direct Vent	Propane	85° to 185° F	0.26	0.40	5.0	8.5	9.5	3/4	3/4	27-1/2	18-1/2	9-3/4	82	95%
★ RTGH-CM95XLN	11,000-199,900	Outdoor	Nat. Gas	85° to 185° F	0.26	0.40	5.0	8.5	9.5	3/4	3/4	27-1/2	18-1/2	9-3/4	82	96%
★ RTGH-CM95XLP	11,000-199,900	Outdoor	Propane	85° to 185° F	0.26	0.40	5.0	8.5	9.5	3/4	3/4	27-1/2	18-1/2	9-3/4	82	95%

★ ENERGY STAR® compliant model.



Commercial Tankless Systems

This custom-built tankless solution arrives on the jobsite factory-assembled with single point connections including

- RTGH-CM95 Condensing Tankless Water Heaters
- Factory installed system control manifold
- Pre-sized water and gas manifold
- Electrical wiring
- Condensate lines

Configurations

- Wall mounted system
- Wall hung system
- Free-standing system

System Options

- 2-6 tankless units per system

Engineered Solution by Rheem

- Scalable from 11,000 BTU/h to 1,199,400 BTU/h per system (6 units max per system rack, multiple racks can be linked up to 20 total units or 3,998,000 BTU/h)
- Multiple configurations
- Options for future expansion

Installation Savings

- Reduce installation costs with single point connections

Industry Leading Solutions

- Minimum side to side clearances = 1/2 inch (to combustibles)
- Minimum flow rate = 0.26 GPM
- Minimum activation rate = 0.40 GPM
- UL-1738 & ULC-S636 certification on PPs venting accessories

Redundancy

- Modular system allows isolation to reduce downtime

Warranty

- 5-Year heat exchanger, 5-years parts, 1-year rack parts and 1-year labor warranty*

*See Commercial Warranty Certificate for complete information

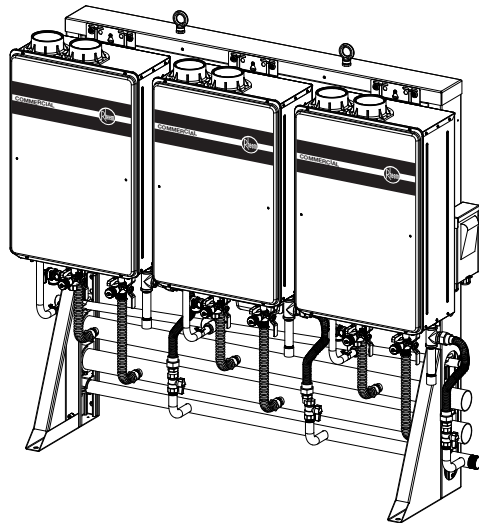

Wall Hanging Tankless System



MODEL NUMBER	NUMBER OF UNITS	SYSTEM DESCRIPTION	FUEL TYPE	DIMENSIONS (HEIGHT X WIDTH X DEPTH)	ASSEMBLED WEIGHT (LBS.)	SHIPPING WEIGHT (LBS.)	LAYOUT
RTR-WH220DVLN	2-Units	Indoor Wall Hanging	Nat. Gas	54.30" x 45.38" x 11.50"	220	320	
RTR-WH220XLN	2-Units	Outdoor Wall Hanging	Nat. Gas	54.30" x 45.38" x 11.50"	220	320	
RTR-WH220DVL P	2-Units	Indoor wall hanging	LP Gas	54.30" x 45.38" x 11.50"	220	320	
RTR-WH220XLP	2-Units	Outdoor Wall Hanging	LP Gas	54.30" x 45.38" x 11.50"	220	320	
RTR-WH330DVLN	3-Units	Indoor Wall Hanging	Nat. Gas	54.30" x 65.57" x 11.50"	310	430	
RTR-WH330XLN	3-Units	Outdoor Wall Hanging	Nat. Gas	54.30" x 65.57" x 11.50"	310	430	
RTR-WH330DVL P	3-Units	Indoor Wall Hanging	LP Gas	54.30" x 65.57" x 11.50"	310	430	
RTR-WH330XLP	3-Units	Outdoor Wall Hanging	LP Gas	54.30" x 65.57" x 11.50"	310	430	

Wall Mount Tankless System



MODEL NUMBER	NUMBER OF UNITS	SYSTEM DESCRIPTION	FUEL TYPE	DIMENSIONS (HEIGHT X WIDTH X DEPTH)	ASSEMBLED WEIGHT (LBS.)	SHIPPING WEIGHT (LBS.)	LAYOUT
RTR-WM220DVLN	2-Units	Indoor Wall Mount	Nat. Gas	54.30" x 41.50" x 15.00"	250	360	
RTR-WM220XLN	2-Units	Outdoor Wall Mount	Nat. Gas	54.30" x 41.50" x 15.00"	250	360	
RTR-WM220DVL P	2-Units	Indoor Wall Mount	LP Gas	54.30" x 41.50" x 15.00"	250	360	
RTR-WM220XLP	2-Units	outdoor wall mount	LP Gas	54.30" x 41.50" x 15.00"	250	360	
RTR-WM330DVLN	3-Units	Indoor Wall Mount	Nat. Gas	54.30" x 61.25" x 15.00"	350	460	
RTR-WM330XLN	3-Units	Outdoor Wall Mount	Nat. Gas	54.30" x 61.25" x 15.00"	350	460	
RTR-WM330DVL P	3-Units	Indoor Wall Mount	LP Gas	54.30" x 61.25" x 15.00"	350	460	
RTR-WM330XLP	3-Units	Outdoor Wall Mount	LP Gas	54.30" x 61.25" x 15.00"	350	460	



Freestanding Tankless Rack System



MODEL NUMBER	NUMBER OF UNITS	SYSTEM DESCRIPTION	FUEL TYPE	DIMENSIONS (HEIGHT X WIDTH X DEPTH)	ASSEMBLED WEIGHT (LBS.)	SHIPPING WEIGHT (LBS.)	LAYOUT
RTR-FS411DVLN	2-Units	Indoor Free Standing	Nat. Gas	54.30" x 41.50" x 25.00"	240	350	
RTR-FS411XLN	2-Units	Outdoor Free Standing	Nat. Gas	54.30" x 41.50" x 25.00"	240	350	
RTR-FS411XVLP	2-Units	Outdoor Free Standing	LP Gas	54.30" x 41.50" x 25.00"	240	350	
RTR-FS420DVLN	2-Units	Indoor Free Standing	Nat. Gas	54.30" x 41.50" x 25.00"	240	350	
RTR-FS420XLN	2-Units	Outdoor Free Standing	Nat. Gas	54.30" x 41.50" x 25.00"	240	350	
RTR-FS420XLP	2-Units	Outdoor Free Standing	LP Gas	54.30" x 41.50" x 25.00"	240	350	
RTR-FS630DVLN	3-Units	Indoor Free Standing	Nat. Gas	54.30" x 61.25" x 25.00"	350	490	
RTR-FS630XLN	3-Units	Outdoor Free Standing	Nat. Gas	54.30" x 61.25" x 25.00"	350	490	
RTR-FS630XLP	3-Units	Outdoor Free Standing	LP Gas	54.30" x 61.25" x 25.00"	350	490	
RTR-FS421DVLN	3-Units	Indoor Free Standing	Nat. Gas	54.30" x 41.50" x 25.00"	330	440	
RTR-FS421XLN	3-Units	Outdoor Free Standing	Nat. Gas	54.30" x 41.50" x 25.00"	330	440	
RTR-FS421XLP	3-Units	Outdoor Free Standing	LP Gas	54.30" x 41.50" x 25.00"	330	440	

Freestanding Tankless Rack System



MODEL NUMBER	NUMBER OF UNITS	SYSTEM DESCRIPTION	FUEL TYPE	DIMENSIONS (HEIGHT X WIDTH X DEPTH)	ASSEMBLED WEIGHT (LBS.)	SHIPPING WEIGHT (LBS.)	LAYOUT
RTR-FS422DVLN	4-Units	Indoor Free Standing	Nat. Gas	54.30" x 41.50" x 25.00"	420	530	
RTR-FS422XLN	4-Units	Outdoor Free Standing	Nat. Gas	54.30" x 41.50" x 25.00"	420	530	
RTR-FS422XLP	4-Units	Outdoor Free Standing	LP Gas	54.30" x 41.50" x 25.00"	420	530	
RTR-FS632DVLN	5-Units	Indoor Free Standing	Nat. Gas	54.30" x 61.25" x 25.00"	530	670	
RTR-FS632XLN	5-Units	Outdoor Free Standing	Nat. Gas	54.30" x 61.25" x 25.00"	530	670	
RTR-FS632XLP	5-Units	Outdoor Free Standing	LP Gas	54.30" x 61.25" x 25.00"	530	670	
RTR-FS633DVLN	6-Units	Indoor Free Standing	Nat. Gas	54.30" x 61.25" x 25.00"	620	760	
RTR-FS633XLN	6-Units	Outdoor Free Standing	Nat. Gas	54.30" x 61.25" x 25.00"	620	760	
RTR-FS633XLP	6-Units	Outdoor Free Standing	LP Gas	54.30" x 61.25" x 25.00"	620	760	



Large Volume Custom Heavy Duty (EVR, EVS, EHS Series)

Features

- 150, 200, 250, 300, 400, 500, 600, 750, 1,000, 1,250, 1500, 2,000 and 2,500-Gallon storage capacities
- 144 kW through 900 kW
- 208, 240, 277, 380, 415, 480 and 600 Voltages
- Vertical round, vertical square and horizontal models
- Glass lined steel tank
- Incoloy™ heating elements
- Internal fusing (above 120 amps)
- Enamel finished galvanized steel jacket
- Magnesium anodes
- Immersion thermostat
- Manual reset high limit
- Full length hinged doors with key lock
- Terminal block connections
- ASME temperature and pressure relief valve
- Channel iron skid base (except 150 & 200-gallon round models)
- 180° F temperature operation
- 125 PSI working pressure
- Hand-hole sediment cleanout
- Safety drain pan (square models)
- Control voltage on/off switch with pilot light
- Low lead compliant

Optional Features

- Low water cut-off
- Pilot lights
- Manual limiting switches
- Alarm bell
- Shunt trip disconnect (field installed)
- Low or high water pressure switch
- And more!

Warranty

- 3-Year limited tank and 1-year limited parts warranty*

*See Commercial Warranty Certificate for complete information



- Vertical round models above 90 kW at 208V, 240V, or 380V and 162 kW at 415V, 480V or 600V exceed the capacity of a single control box and may require multiple control panels. Consult the factory for specific details and optional construction.
- Vertical square construction is available as an option for models that exceed the listed kW limits.
- Control panel heights on vertical round models may exceed tank height – consult factory for specific heights on models with inputs above 72 kW.

DIMENSIONAL INFORMATION (All dimensions shown in inches)

MODEL NUMBER	GAL. CAP.	MAX. KW.	HEIGHT	WIDTH	DEPTH	HEIGHT TO COLD INLET	WATER CONNECTION		APPROX. SHIP. WT. (LBS)
							INLET	OUTLET	
VERTICAL ROUND									
EVRO150	150	144	65-1/2	32	38-3/4	7-3/4	1-1/2	1-1/2	650
EVRO200	200	162	78	32	38-3/4	7-3/4	1-1/2	1-1/2	750
EVRO250	250	162	92	34	40-3/4	19-1/2	1-1/2	1-1/2	1,165
EVRO300	300	162	80	40	46-3/4	21	2	2	1,350
EVRO400	400	162	80	46	52-3/4	22-1/2	2	2	1,590
EVRO500	500	396	92	46	52-3/4	22-1/2	2	2	1,700
EVRO600	600	396	92	52	60-3/4	24-1/2	2-1/2	2-1/2	2,010
EVRO800	750	396	104	52	60-3/4	24-1/2	2-1/2	2-1/2	2,450
EVRO1000	950	396	128	52	60-3/4	24-1/2	2-1/2	2-1/2	3,160
VERTICAL SQUARE									
EVS1250	1,250	900	132-1/2	64-1/2	64-1/2	23-1/4	3	3	3,560
EVS1500	1,500	900	128-1/2	70-1/2	70-1/2	25-1/4	3	3	4,120
EVS2000	2,000	900	140-1/2	76-1/2	76-1/2	27-1/4	3	3	4,350
EVS2500	2,500	900	146-1/2	82-1/2	82-1/2	29	3	3	5,750
HORIZONTAL									
EHS0150	150	144	37	68-1/2	34-1/4	12	2	2	1,180
EHS0200	200	180	37	78	34-1/4	12	2	2	1,370
EHS0250	250	225	39	90-1/4	36-1/4	13	2	2	1,450
EHS0300	300	270	45	78-1/4	42-1/4	14-3/4	2	2	1,530
EHS0400	400	360	52	78-1/4	48-1/4	16	2	2	1,750
EHS0500	500	450	52	90-3/4	48-1/4	16	2	2	1,860
EHS0600	600	540	58	90-3/4	54-1/4	13-1/2	2-1/2	2	2,340
EHS0800	750	720	58	102-1/4	54-1/4	13-1/2	2-1/2	2	2,850
EHS1000	1,000	900	58	126-1/4	54-1/4	13-1/2	2-1/2	2	3,040
EHS1250	1,250	900	64	130-1/4	60-1/4	15	3	3	3,750
EHS1500	1,500	900	70	126-1/4	66-1/4	16	3	3	4,340
EHS2000	2,000	900	76	137-1/4	72-1/4	17-1/2	3	3	4,580
EHS2500	2,500	900	82	144-1/4	78-1/4	16-1/2	3	3	6,060



Heavy Duty (E, ES Series)

Features

- 98% Thermal efficiency
- 50 to 175-Gallon capacities
- Up to 438 gallons GPH at a 100 degree F rise
- 190° F Maximum delivered temperature for E series; 160° F for ES50; 180° F for ES85 and ES120 models
- Thick foam insulation for minimal standby heat loss
- 3 kW through 108 kW
- 208, 240 or 480 VAC in either single phase or 3-phase; 277 VAC single phase
- 2000, 3000, 4000, 4500, 5000 and 6000 in the four voltages; 9000 watt element at 480 VAC
- Available in 1, 3, 6, 9 or 12 element configurations for your specific kW application
- Elements are Lifeguard™ stainless steel, screw-in type that resist burn out and corrosion
- Temperature and pressure relief valve at top of 175-gallon model and side on all other models
- Water connections: hot and cold water inlets are 2-1/2" NPT dielectric nipples on the 175-gallon model and 1-1/2" on all other models
- Low lead compliant

Easy Installation & Service

- Control box is located at the front of unit for easy wiring during installation

– Multiple knockout holes accommodate a variety of conduit sizes

- Exclusive! System Sentinel™ provides a diagnostic panel with LEDs that correspond to the number, location and status of each element
- Exclusive! Full-port, full-flow, brass drain valve for faster draining
- Minimum distance to combustible is zero inches from jacket and 18 inches from access door
- All models approved for installation on combustible flooring

Warranty

- 3-Year limited tank, upgradable to 5-years and 1-year limited parts warranty*

*See Commercial Warranty Certificate for complete information

In accordance with ANSI test procedures, these models tested below the maximum allowable standby loss levels of ASHRAE (Part of the Federally mandated Energy Policy Act (EPact)). Also exceeds energy codes of all states including California Energy Commission (CEC).



(With
Optional
Seal Kit)

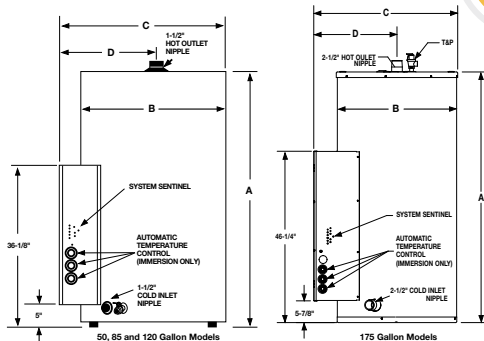

4000
PROCLUB
POINTS

ELITEXPRESS
48 HOUR
DELIVERY



MODEL NUMBERS						
SURFACE MOUNTED THERMOSTATS TANK CAPACITY IN GALLONS			IMMERSION THERMOSTATS TANK CAPACITY IN GALLONS			
50	85	120	50	85	120	175
N/A	N/A	N/A	N/A	N/A	N/A	E175A-3-G
ES50-6-G	ES85-6-G	ES120-6-G	E50-6-G	E85-6-G	E120-6-G	E175A-6-G
ES50-9-G	ES85-9-G	ES120-9-G	E50-9-G	E85-9-G	E120-9-G	E175A-9-G
ES50-12-G	ES85-12-G	ES120-12-G	E50-12-G	E85-12-G	E120-12-G	E175A-12-G
ES50-15-G	ES85-15-G	ES120-15-G	E50-15-G	E85-15-G	E120-15-G	E175A-15-G
ES50-18-G	ES85-18-G	ES120-18-G	E50-18-G	E85-18-G	E120-18-G	E175A-18-G
ES50-24-G	ES85-24-G	ES120-24-G	E50-24-G	E85-24-G	E120-24-G	E175A-24-G
ES50-27-G	ES85-27-G	ES120-27-G	E50-27-G	E85-27-G	E120-27-G	E175A-27-G
ES50-30-G	ES85-30-G	ES120-30-G	E50-30-G	E85-30-G	E120-30-G	E175A-30-G
ES50-36-G	ES85-36-G	ES120-36-G	E50-36-G	E85-36-G	E120-36-G	E175A-36-G
ES50-45-G	ES85-45-G	ES120-45-G	E50-45-G	E85-45-G	E120-45-G	E175A-45-G
ES50-54-G	ES85-54-G	ES120-54-G	E50-54-G	E85-54-G	E120-54-G	E175A-54-G
N/A	N/A	N/A	N/A	N/A	N/A	E175A-60-G
N/A	N/A	N/A	N/A	N/A	N/A	E175A-72-G
N/A	N/A	N/A	N/A	E85A-81-GS	E120A-81-GS	E175A-81-G
N/A	N/A	N/A	N/A	N/A	N/A	E175A-108-G

DIMENSIONAL INFORMATION (ALL DIMENSIONS SHOWN IN INCHES)						
MODEL NUMBER	A	B	C	D	APPROX. SHIP. WT. (LBS)	
					STD.	ASME
E(S)50(A)	43-5/8	26-1/4	32	19	270	320
E(S)85(A)	57-11/16	28-1/4	34	20	350	380
E(S)120(A)	67-5/8	30-1/4	36	21	430	460
E175A	69-1/2	32-1/4	38-1/2	22-1/4	-	700

WATER TEMPERATURE RATINGS				
MODEL NUMBER	THERMOSTAT TYPE	MIN. DELIVERED TEMP.	MAX. DELIVERED TEMP.	HIGH TEMP. LIMIT
ES50	SURFACE	90° F	160° F	180° F
ES85, ES120	SURFACE	120° F	180° F	190° F
E50, E85, E120	IMMERSION	90° F	190° F	200° F
E175A	IMMERSION	90° F	190° F	200° F

RECOVERY CAPACITIES							
INPUT KW	EQUIVALENT BTU/H	RECOVERY IN GALLONS/HR. (GPH) AT VARIOUS TEMPERATURE RISES					
		40° F	60° F	80° F	100° F	120° F	140° F
3	10,236	31	20	15	12	10	9
6	20,473	62	41	31	25	21	18
9	30,709	92	61	46	37	31	26
12	40,946	123	82	61	49	41	35
15	51,182	154	102	77	61	51	44
18	61,418	184	123	92	74	61	53
24	81,891	246	164	123	98	82	70
27	92,128	276	184	138	111	92	79
30	102,364	307	205	154	123	102	88
36	122,837	369	246	184	147	123	105
45	153,546	461	307	230	184	154	132
54	184,256	553	369	276	221	184	158
81	276,388	838	558	419	335	279	239
108	368,518	1116	744	558	446	372	320

ASME construction available only on Immersion Thermostat models. All models are North Carolina Code compliant.

Minimum distance to combustibles - 0" from jacket, 18" from access door. All models approved for installation on combustible flooring.



PowerPack Heavy and Medium Duty (E Series)

Features

- 98% Maximum recovery efficiency
- 13, 19.9, 30 and 40-Gallon capacities
- 3 kW through 36 kW
- 208, 240, 277 and 480 Voltages
- Field convertible
- Single phase and factory wired
- Lifeguard™ heating elements
- Immersion thermostat
- 3/4" Water connections
- 2-1/2" Rigid polyurethane foam insulation
- System Sentinel LED diagnostic system
- Integral fusing on each element
- Two anode rods for long life and corrosion resistance
- Full-port, full-flow brass drain valve
- Factory installed CSA/ASME rated temperature and pressure relief valve
- Low lead compliant
- Electrical connections: pre-wired, accessible control box with multiple knock-outs on side in size selections to match the National Electric Code
- Single panel control box with hinged door: provides immediate access to all electrical components and elements

- Terminal block: all models are equipped with U.L. listed terminal blocks
- All units are furnished with a fused 120 volt control circuit; this circuit is created by an internal multi-tap transformer that has four (4) taps for the primary voltages, 208, 240, 277 and 480

Warranty

- 3-Year limited tank, upgradable to 5-years and 1-year limited parts warranty*

*See Commercial Warranty Certificate for complete information

In accordance with ANSI test procedures, these models tested below the maximum allowable standby loss levels of ASHRAE (Part of the Federally mandated Energy Policy Act (EPact)). Also exceeds energy codes of all states including California Energy Commission (CEC).



(With
Optional
Seal Kit)

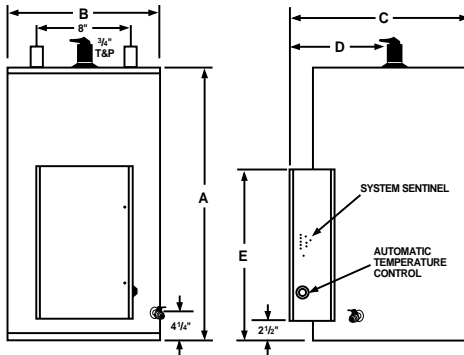

MODEL NUMBERS				
INPUT KW	IMMERSION THERMOSTATS TANK CAPACITY IN GALLONS			
	12	20	30	40
3	E12A-3-G	E20A-3-G	E30A-3-G	E40A-3-G
6	E12A-6-G	E20A-6-G	E30A-6-G	E40A-6-G
9	E12A-9-G	E20A-9-G	E30A-9-G	E40A-9-G
12	N/A	E20A-12-G	E30A-12-G	E40A-12-G
15	N/A	E20A-15-G	E30A-15-G	E40A-15-G
18	N/A	E20A-18-G	E30A-18-G	E40A-18-G
24	N/A	N/A	E30A-24-G	E40A-24-G
27	N/A	N/A	E30A-27-G	E40A-27-G
30	N/A	N/A	E30A-30-G	E40A-30-G
36	N/A	N/A	E30A-36-G	E40A-36-G

RECOVERY CAPACITIES							
INPUT KW	EQUIVALENT BTU/H	RECOVERY IN GALLONS/HR. (GPH) AT VARIOUS TEMPERATURE RISES					
		40° F	60° F	80° F	100° F	120° F	140° F
3	10,236	31	21	16	12	10	9
6	20,473	62	41	31	25	21	18
9	30,709	93	62	47	37	31	27
12	40,946	124	83	62	50	41	35
15	51,183	155	103	78	62	52	44
18	61,420	186	124	93	74	62	53
24	81,893	248	165	124	99	83	71
27	92,129	279	186	140	112	93	80
30	102,366	310	207	155	124	103	89
36	122,839	372	248	186	149	124	106

DIMENSIONAL INFORMATION (All dimensions shown in inches)						
MODEL NUMBER	A	B	C	D	E	APPROX. SHIP. WT. (LBS)
E12A	28-1/2	19	24-1/4	14-3/4	26-1/4	135
E20A	36-1/2	19	24-1/4	14-3/4	26-1/4	160
E30A	49-1/4	19	24-1/4	14-3/4	32-1/2	192
E40A	53-3/4	21	26-3/4	16-1/2	32-1/2	228

WATER TEMPERATURE RATINGS					
MODEL NUMBER	GALLON CAPACITY	THERMOSTAT TYPE	MIN. DELIVERED TEMP.	MAX. DELIVERED TEMP.	HIGH TEMP. LIMIT
E12A	13	IMMERSION	90°F	190° F	200° F
E20A	19.9	IMMERSION	90°F	190° F	200° F
E30A	30	IMMERSION	90°F	190° F	200° F
E40A	40	IMMERSION	90°F	190° F	200° F

All models are North Carolina and Massachusetts Code compliant.



Marathon® Heavy Duty Non-Metallic Heavy and Medium Duty (MHD Series)

Non-metallic Tank Features

- Seamless, blow-molded, polybutene tank – impervious to rust and corrosion
- Multiple layers of filament wound fiberglass give the tank unmatched strength
- Polyurethane insulation helps reduce energy consumption
- Recessed drain valve is out of the way of brooms and scrubbers
- High temperature polysulfone dip tube
- Tough molded polyethylene outer shell resists dents, scratches, and salt air

Efficiency

- Well insulated for reduced standby heat loss
- Pipe wrap energy saving kit included to achieve maximum energy savings

Performance

- Recovery Capacity: 18.2 gallons per hour (delivers approximately 78 gallons of hot water in the first hour for 75-gallon models, 91 gallons for 85-gallon models and 104 gallons for 105-gallon models)**
- Thermostat capable of delivering water temperature above 181° F for high temperature applications

Easy Installation & Service

- Marathon's lightweight tank is easier to maneuver and position
- Bowl shaped tank bottom allows complete sediment draining
- Water tight grommets keep out over-head moisture and condensation

Plus...

- Thermally fused upper element provides protection against dry-firing
- Titanium upper and lower elements for superior resistance to lime build-up
- Full-flow, brass drain valve
- Temperature and pressure relief valve and factory installed vacuum relief valve
- Low lead compliant
- Standard replacement parts

Warranty

- 10-year limited tank warranty and 1-year on parts*

*See Warranty Certificate for complete information



DESCRIPTION			FEATURES		ROUGHING IN DIMENSIONS (SHOWN IN INCHES)			
T Y P E	GAL. CAP.	MODEL NUMBER	RECOVERY IN G.P.H. 100° F RISE**	FIRST HOUR DELIVERY G.P.H.	TANK HEIGHT A	HEIGHT TO WATER CONN. B	DIAMETER C	APPROX. SHIP WT. (LBS)
Tall	75	MHD75245	18.2	78	58-5/8	62-5/8	28-1/4	122
Tall	85	MHD85245	18.2	91	66-1/4	70-1/4	28-1/4	134
Tall	105	MHD105245	18.2	104	66-3/4	70-3/4	30-1/4	152

**Recovery Capacity is based upon a 100° F water temperature rise and calculated per ANSI Z21.10.3 standards. First hour hot water delivery is based upon 77° water temperature rise.

- Water heaters furnished with standard 240 volt AC, single phase non-simultaneous wiring; available in 3800 and 4500 watt double element configuration (85-gallon 3000 watt).
- For height to top of heat traps add 3-1/2" to the height to water connection.
- Maximum test pressure: 300 PSI; Maximum working pressure: 150 PSI

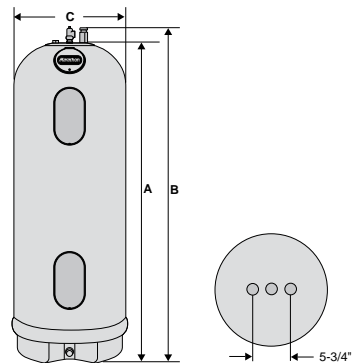

Marathon® Eclipse™ Non-Metallic Heavy and Medium Duty (MELD Series)

Terminal Block

- Easy to convert standard models from simultaneous to non-simultaneous, single phase to three phase
- Field convertible to meet any light-duty application need
- Available on all models

High Efficiency Savings

- Polyurethane insulation reduces energy consumption and standby heat loss
- Pipe wrap kit included to achieve maximum energy savings

Unmatched Strength & Durability

- Non-metallic, seamless, blow-molded polybutene inner tank protects against rust and corrosion
- Multiple layers of filament-wound fiberglass give the tank unmatched strength
- Recessed brass drain valve is out the way of brooms and scrubbers
- High temperature polysulfone dip tube
- Tough molded polyethylene outer shell resists dents, scratches, and salt air

- Titanium upper and lower elements for superior resistance to lime build-up
- All plastic tank eliminates the need for an anode rod

Easy Installation & Service

- Lightweight tank is easier to maneuver and position
- Bowl shaped tank bottom allows complete sediment draining
- Water tight grommets protects against over-head moisture and condensation

Performance

- 170°F Maximum temperature setting
- Perfect for high water temperature applications up to 170°F
- Low lead compliant
- Recovery Capacity: 18.2 GPH (Gallon per Hour)
- First Hour Delivery: 78 gallons per hour for the 75-gallon model, 91 gallons per hour for the 85-gallon model and 104 gallons per hour for the 105-gallon model

Plus...

- Temperature and pressure relief valve included
- Factory installed vacuum relief valve
- Standard replacement parts

Warranty

- 10-year limited tank warranty and 1-year on parts*

*See Commercial Warranty Certificate for complete information

All models tested according to ANSI test procedures and meet or exceed the thermal efficiency and standby loss requirements of current ASHRAE standards (EPACT). Also exceeds energy efficiency codes of all states including California Energy Commission (CEC).



All Marathon Eclipse Light Duty models are available in 6/6 simultaneous configurations with terminal block in both fused and non-fused configurations. All water heaters with power requirements over 48 Amps come Standard in the fused configuration.

DESCRIPTION			FEATURES		ROUGHING IN DIMENSIONS (SHOWN IN INCHES)			
T Y P E	GALLON CAPACITY	MODEL NUMBER	RECOVERY IN G.P.H. 100° F RISE**	FIRST HOUR DELIVERY G.P.H.	TANK HEIGHT A	HEIGHT TO WATER CONN. B	DIAMETER C	APPROX. SHIP WT. (LBS.)
Tall	75	MELD75-TB	49	78	58-5/8	62-5/8	28-1/4	128
Tall	85	MELD85-TB	49	91	66-1/4	70-1/4	28-1/4	140
Tall	105	MELD105-TB	49	104	66-3/4	70-3/4	30-1/4	152

**Recovery Capacity is based upon a 100° F water temperature rise and calculated per ANSI Z21.10.3 standards

- Maximum test pressure: 300 PSI; Maximum working pressure: 150 PSI

277 Volt Rated Water Heaters

FACTORY SHIP. RATING			AMPS AND OTHER RATED VOLTAGES									
VOLTS	277		277		240		240		208		208	
OPERATION	Sim		Non-Sim		Sim		Non-Sim		Sim		Non-Sim	
PHASE	1-PH	3-PH	1-PH & 3-PH		1-PH	3-PH	1-PH & 3-PH		1-PH	3-PH	1-PH & 3-PH	
RATING	12100	12100	6050	9080	9080	4540	6820	6820	3410			
BREAKER	60	50	30	50	45	25	45	35	20			

MELD Factory Models

	SIZE	208V	240V	277V	480V
SIM OR NON- SIM		6/6	6/6	6/6	6/6
	75	✓	✓	✓	✓
	85	✓	✓	✓	✓
	105	✓	✓	✓	✓

- All models are factory shipped with sim configuration.

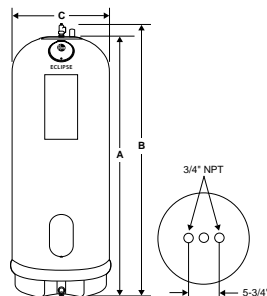

Eclipse™ Non-Metallic Heavy and Medium Duty (ME Series)

Features

- 98% Thermal efficiency
- Foam insulated for reduced standby heat loss
- Recovery rate: Up to 99 gallons GPH at 100 degree rise
- 170° F Maximum temperature setting
- 85 and 105-Gallon capacities
- 12.4, 18 or 24 kW
- Voltage options: 208, 240, or 480 VAC in either single phase or 3-phase (277 VAC in single phase only)
- Element wattages: 3100, 4500 or 6000 in each of the four voltages. The elements are low watt density design (46, 67, 90 watts/sq. in.) with titanium sheath for superior protection
- Non-metallic tank – no anode rods required
- High density polyethylene dent and scratch resistant jacket
- System Sentinel LED indicators are provided for each element to show when power is on
- Four titanium elements for resistance to lime build-up
- Full-port, full-flow, brass drain valve for faster draining
- Temperature and pressure relief valve at top of unit

- Water connections at the top of the tank are 1" swivel nuts
- A nipple is installed on the outlet (1" x 3" long)
- The inlet has a vacuum valve connected with a 1 x 1 x 3/4 tee and a 1" close nipple to the swivel
- Low lead compliant

Easy Installation & Service

- Eclipse's lightweight tank is easier to maneuver and position
- Control circuit switch provided for dry fire protection during installation
- Bowl shaped tank bottom drains completely
- Recessed drain valve is out of the way of brooms and scrubbers

Warranty

- 10-Year limited tank warranty*

*See Commercial Warranty Certificate for complete information

In accordance with ANSI test procedures, these models tested below the maximum allowable standby loss levels of ASHRAE (Part of the Federally mandated Energy Policy Act (EPact)). Also exceeds energy codes of all states including California Energy Commission (CEC).



MODEL NUMBERS		
INPUT KW	SURFACE MOUNTED THERMOSTATS TANK CAPACITY IN GALLONS	
	85	105
12.4	ME85-12-G	ME105-12-G
18	ME85-18-G	ME105-18-G
24	ME85-24-G	ME105-24-G

RECOVERY CAPACITIES						
INPUT KW	EQUIVALENT BTU/H	RECOVERY IN GALLONS/HR. (GPH) AT VARIOUS TEMPERATURE RISES				
		40° F	60° F	80° F	100° F	120° F
12.4	42,309	126	84	63	50	42
18	61,420	186	124	93	74	62
24	81,893	248	165	124	99	83

DIMENSIONAL INFORMATION (All dimensions shown in inches)					
MODEL NUMBER	A	B	C	D	APPROX. SHIP. WT. (LBS)
ME85	28-1/4	66-1/4	70-1/4	4-1/2	170
ME105	30-1/4	66-1/2	70-3/4	4-1/2	185

WATER TEMPERATURE RATINGS				
MODEL NUMBER	GALLON CAPACITY	THERMOSTAT TYPE	MIN. DELIVERED TEMP.	MAX. DELIVERED TEMP.
ME85	85	SURFACE	90° F	170° F
ME105	105	SURFACE	90° F	170° F

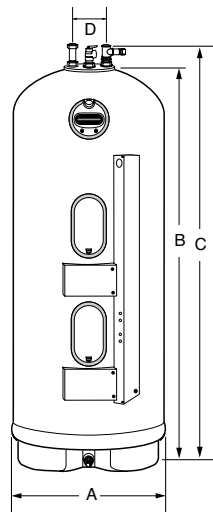

Booster Heavy and Medium Duty (E10 Series)

Features

- 98% Thermal efficiency
- 10-Gallon capacity
- 6 kW through 54 kW
- UL approved field change to simple phase
- Certified for 150 PSI maximum working pressure
- UL Sanitation (standard)
- Factory wired three phase
- System Sentinel LED diagnostic system
- All units are furnished with a fused 120 volt control circuit. All controls (thermostats, high temperature limit, etc.) are operated off of this basic 120 volt control circuit. This circuit is created by an internal multi-tap transformer of unique design that has four (4) taps for the primary voltages, 208, 240, 277 and 480
- Two heavy-duty anode rods help resist corrosion and extend tank life
- Factory installed T&P valve
- Immersion thermostats
- 6-Inch stainless steel legs
- Low lead compliant

Long Life Tank Design

- Proprietary steel formulation with a unique coat of high temperature porcelain enamel
- Maximizes corrosion resistance resulting in a superior tank design

Long Life Heating Elements

- Separate screw-in type elements feature a Nichrome wire filament, embedded in magnesium oxide sealed in a copper tube to resist water chemical corrosion...for long element life and a long life performance
- Elements are directly immersed in the water for maximum recovery efficiency (98%) and are easily changed by simply screwing new ones into the tank

Warranty

- 3-Year limited tank, upgradable to 5-years and 1-year limited parts warranty*

*See Commercial Warranty Certificate for complete information



These models meet the energy efficiency levels of ASHRAE (Part of the Federally mandated Energy Policy Act (EPact)). Also exceeds energy efficiency codes of all states including California Energy Commission (CEC). All models are North Carolina Code compliant.

Specifically designed to support commercial dish washers.



RECOVERY CAPACITIES								
MODEL NUMBER	INPUT KW	EQUIVALENT BTU/H	RECOVERY IN GALLONS/HR. (GPH) AT VARIOUS TEMPERATURE RISES					
			40° F	60° F	80° F	100° F	120° F	140° F
E10-6-G	6	20,473	62	41	31	25	21	18
E10-9-G	9	30,709	92	61	46	37	31	26
E10-12-G	12	40,946	123	82	61	49	41	35
E10-15-G	15	51,182	154	102	77	61	51	44
E10-18-G	18	61,418	184	123	92	74	61	53
E10-24-G	24	81,891	246	164	123	98	82	70
E10-27-G	27	92,128	276	184	138	111	92	79
E10-30-G	30	102,364	307	205	154	123	102	88
E10-36-G	36	122,837	369	246	184	147	123	105
E10-45-G	45	153,546	461	307	230	184	154	132
E10-54-G	54	184,256	553	369	276	221	184	158

Approximate Weight – 110 Lbs.

WATER TEMPERATURE RATINGS				
GALLON CAPACITY	THERMOSTAT TYPE	MIN. DELIVERED TEMP.	MAX. DELIVERED TEMP.	HIGH TEMP. LIMIT
10	IMMERSION	90° F	190° F	200° F

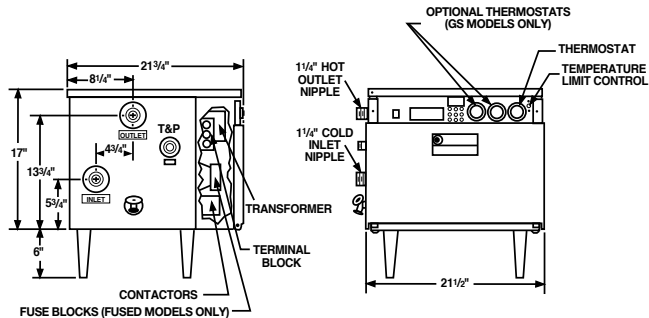

Hybrid (HPLD Series)

Efficiency

- High 3.55 - 3.70 UEF reduces operating cost
- ENERGY STAR® rated

Performance

- Delivers more hot water than most standard electric water heaters – 67 gallons first-hour delivery for 50-gallon model, 75 gallons FHD for 65-gallon model and 89 gallons FHD for 80-gallon model
- Ambient operating range: 37-145° F is widest in class, offering more days of HP operation annually; designed to meet Northern Climate Spec (Tier 3)
- Maximum temperature setting is 150°F

Easy Installation

- Easy access side connections
- Quick access to electrical junction box
- Easily replaces a standard electric water heater

Integration

- LCD Screen with built-in water sensor alert with audible alarm
- EcoNet® WiFi-connected† technology and free mobile app gives users control over water systems, allowing for customizable temperature, vacation settings, energy savings and system monitoring at home or away. Visit Rheem.com/hybridsolutions
- Water sensor detects water outside of the unit and sends an alert via the free Rheem EcoNet® mobile app to the homeowner



Operation Modes

- Energy Saver
- Heat Pump
- High Demand
- Electric
- Vacation: 2-28 days (or placed on hold indefinitely)

Plus...

- Premium grade anode rod with resistor extends the life of the tank
- 3/4" NPT water inlet and outlet; 3/4" condensate drain connections
- Incoloy stainless steel resistor elements
- Dry-fire protection
- Easy access, top mounted washable air filter
- 2" Non-CFC foam insulation
- Enhanced flow brass drain valve
- Temperature and pressure relief valve installed
- Low lead compliant

Warranty

- 3-Year limited tank and parts warranty*

*See Commercial Warranty Certificate for complete information

†WiFi broadband internet connection required.



DESCRIPTION					FEATURES				TANK DIMENSIONS (SEE SPACE REQUIREMENTS IN DIAGRAMS BELOW)					
NOMINAL GALLON CAPACITY	RATED GALLON CAPACITY	MODEL NUMBER	UNIFORM ENERGY FACTOR (UEF)	ESTIMATED YEARLY ENERGY COST	COMPRESSOR BTU/H	SOUND LEVEL (dBA)	UEF FIRST HR. RATING G.P.H.	RECOVERY IN G.P.H. 90° F RISE	HEIGHT A	DIAM. B	HT. TO COLD INLET & DRAIN VALVE	HT. TO HOT OUTLET & T&P	UNIT WT. (LBS)	APPROX. SHIP WT. (LBS.)
50	45	★HPLD50	3.55	\$110	4200	49	67	29	61"	22-1/4"	3-5/8"	39-5/8"	178	218
65	59	★HPLD65	3.70	\$161	4200	49	75	29	64"	24-1/4"	3-7/8"	42-3/8"	225	262
80	72	★HPLD80	3.70	\$161	4200	49	89	29	74"	24-1/4"	3-7/8"	52-3/8"	244	281

Estimated energy cost based on a national average electricity cost of \$0.12 /kWh. Uniform Energy Factor and rated gallon capacity based on Department of Energy (DOE) requirements.

All units have integrated WiFi control board.

★ **ENERGY STAR® compliant model.**

DESCRIPTION		DIMENSIONS (SHOWN IN INCHES)											
NOMINAL GALLON CAPACITY	MODEL NUMBER	A	B	C	D	E	F	G	H	I	J	K	L
50	HPLD50	61	22-1/4	47	3-5/8	39-5/8	28	24	36	50	27	77	73
65	HPLD65	64	24-1/4	49	3-7/8	42-3/8	30	26	38	52	29	80	76
80	HPLD80	74	24-1/4	59	3-7/8	52-3/8	30	26	38	52	29	90	86

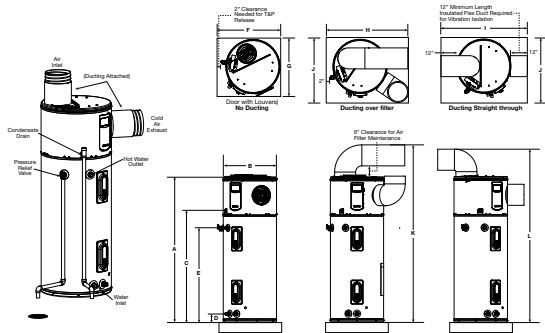

Light Duty (ELD-C Series)

Features

- .92 - .93 UEF
- Our family of light-duty electric water heaters come in 30 through 50-gallon models. They are available in 3kW through 12kW and in 208, 240, 277 and 480 voltages. Maximum temperature setting of 170° F. These units are suited for a wide variety of applications such as retail stores and small offices.
- Simultaneous and non-simultaneous wiring, single phase and three phase are available
- Heavy duty anode rod provides advanced technology and equalizes aggressive water action
- Factory installed brass drain valve for faster draining and servicing
- 2-1/2" of rigid polyurethane foam insulation provides superior insulating qualities resulting in reduced operating costs
- A surface mounted thermostat automatically cycles on and off to maintain the water temperature at a desired preset level
- Low lead compliant

Long Life Tank Design

- Proprietary steel formulation with a unique coat of high temperature porcelain enamel
- Maximizes corrosion resistance resulting in a superior tank design

Long Life Heating Elements

- Patented resistor elements are designed with a specially treated, double layer of magnesium oxide and copper to resist corrosion
- Replacement elements screw in easily

Warranty

- 3-Year limited tank, upgradable to 5-years and 1-year limited parts warranty*

*See Commercial Warranty Certificate for complete information

Consult Factory for Certification Requirements.

NEW UL Approved Electric Conversion Kits

- Provides an easy way to convert standard models to different wattages, volt or phase depending on installation requirements
- Kits are designed for ELD models in all gallon capacities
- All parts needed for the electric conversion are included with Rheem electric conversion kits
- Rheem electric conversion kits provide convenience for contractors, plumbers and installers which saves time and money



DIMENSIONAL INFORMATION

MODEL NUMBER	MIN. WATTS	MAX. WATTS	NOMINAL GALLON CAPACITY	RATED GALLON CAPACITY	UEF FIRST HR. RATING G.P.H.	A (Inches)	B (Inches)	APPROX. SHIPPING WT. (Lbs.)	UNIFORM ENERGY FACTOR (UEF)
ELD30-C	3,000	9,000	30	27	48	45-1/2	17-3/4	90	0.92
ELD40-C	3,000	12,000	40	36	54	46-1/4	22-1/4	108	0.93
ELD52-C	3,000	12,000	50	45	63	57	20-7/16	127	0.93

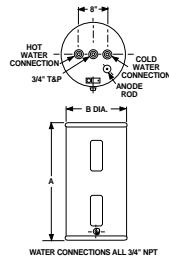

ELECTRICAL CHARACTERISTICS AND CAPACITIES (NON-SIMULTANEOUS/SINGLE OR THREE PHASE OPERATION)

ELEMENT WATTAGE UPPER/LOWER	RECOVERY CAPACITIES GPH @ TEMPERATURE RISE OF					FULL LOAD CURRENT (AMPS) (ALL TERMINALS)			
	40° F	60° F	80° F	100° F	120° F	208	240	277	480
3000/3000	30	20	15	12	10	14.4	12.5	10.8	6.3
4000/4000	41	27	20	16	14	19.2	16.7	14.4	8.3
4500/4500	46	30	23	18	15	21.6	18.8	16.2	9.4
5000/5000	51	34	25	20	17	24	20.8	18.1	10.4
6000/6000	61	41	30	24	20	28.8	25	21.7	12.5

ELECTRICAL CHARACTERISTICS AND CAPACITIES (SIMULTANEOUS/THREE PHASE OPERATION)

ELEMENT WATTAGE UPPER/LOWER	RECOVERY CAPACITIES GPH @ TEMPERATURE RISE OF					FULL LOAD CURRENT (AMPS) (TERMINAL L3/TERMINALS L1 & L2)		
	40° F	60° F	80° F	100° F	120° F	208	240	480
3000/3000	61	41	30	24	20	25/14.4	21.7/12.5	10.8/6.3
4000/4000	81	54	41	32	27	33.3/19.2	28.9/16.7	14.4/8.3
4500/4500	91	61	46	36	30	37.5/21.6	32.5/18.8	16.2/9.4
5000/5000	101	68	51	41	34	41.6/24	36.1/20.8	18/10.4
6000/6000	122	81	61	49	41	50.0/28.8	43.3/25.0	21.7/12.5



Light Duty (ELD-C Series)

Features

- Our family of light-duty electric water heaters come in 30 through 119.9-gallon models. They are available in 3kW through 12kW and in 208, 240, 277 and 480 voltages. Maximum temperature on is greater than 180° F. These units are suited for a wide variety of applications such as retail stores and small offices. Short models are available.
- Simultaneous and non-simultaneous wiring, single phase and three phase are available
- Heavy duty anode rod provides advanced technology and equalizes aggressive water action
- Factory installed brass drain valve for faster draining and servicing
- 2-1/2" of rigid polyurethane foam insulation provides superior insulating qualities resulting in reduced operating costs
- A surface mounted thermostat automatically cycles on and off to maintain the water temperature at a desired preset level
- Low lead compliant

Long Life Tank Design

- Proprietary steel formulation with a unique coat of high temperature porcelain enamel
- Maximizes corrosion resistance resulting in a superior tank design

Long Life Heating Elements

- Patented resistor elements are designed with a specially treated, double layer of magnesium oxide and copper to resist corrosion
- Replacement elements screw in easily

Warranty

- 3-Year limited tank, upgradable to 5-years and 1-year limited parts warranty*

*See Commercial Warranty Certificate for complete information

Consult Factory for Certification Requirements.

NEW UL Approved Electric Conversion Kits*

- Provides an easy way to convert standard models to different wattages, volt or phase depending on installation requirements
- Kits are designed for ELD(S) models in all gallon capacities
- All parts needed for the electric conversion are included with Rheem electric conversion kits
- Rheem electric conversion kits provide convenience for contractors, plumbers and installers which saves time and money

* Not available in Canada.



DIMENSIONAL INFORMATION (All dimensions shown in English and Metric)

MODEL NUMBER	MIN. WATTS	MAX. WATTS	TANK CAPACITY		A		B		APPROX. SHIPPING WT.	
			GALLONS	LITERS	inches	mm	inches	mm	lbs.	kgs.
ELDS30-C	3,000	12,000	30	114	29-1/2	750	22-1/4	565	105	48
ELDS40-C	3,000	12,000	38	144	31-1/2	800	23	584	135	6
ELDS52-C	3,000	12,000	47	178	32-1/2	813	26-1/4	667	150	6
ELD66-C	3,000	12,000	65	246	58-3/4	1492	23	584	170	77
ELD80-C	3,000	12,000	80	303	59	1499	24-1/2	622	200	9
ELD120-C	3,000	12,000	119.9	454	62-1/2	1586	28-1/4	718	330	150

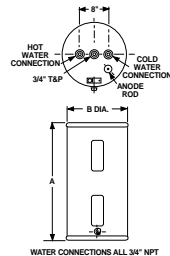

ELECTRICAL CHARACTERISTICS AND CAPACITIES (NON-SIMULTANEOUS/SINGLE OR THREE PHASE OPERATION)

ELEMENT WATTAGE UPPER/LOWER	RECOVERY CAPACITIES GPH @ TEMPERATURE RISE OF					FULL LOAD CURRENT (AMPS) (ALL TERMINALS)			
	40° F	60° F	80° F	100° F	120° F	208	240	277	480
3000/3000	30	20	15	12	10	14.4	12.5	10.8	6.3
4000/4000	41	27	20	16	14	19.2	16.7	14.4	8.3
4500/4500	46	30	23	18	15	21.6	18.8	16.2	9.4
5000/5000	51	34	25	20	17	24	20.8	18.1	10.4
6000/6000	61	41	30	24	20	28.8	25	21.7	12.5

ELECTRICAL CHARACTERISTICS AND CAPACITIES (SIMULTANEOUS/THREE PHASE OPERATION)

ELEMENT WATTAGE UPPER/LOWER	RECOVERY CAPACITIES GPH @ TEMPERATURE RISE OF					FULL LOAD CURRENT (AMPS) (TERMINAL L3/TERMINALS L1 & L2)		
	40° F	60° F	80° F	100° F	120° F	208	240	480
3000/3000	61	41	30	24	20	25/14.4	21.7/12.5	10.8/6.3
4000/4000	81	54	41	32	27	33.3/19.2	28.9/16.7	14.4/8.3
4500/4500	91	61	46	36	30	37.5/21.6	32.5/18.8	16.2/9.4
5000/5000	101	68	51	41	34	41.6/24	36.1/20.8	18/10.4
6000/6000	122	81	61	49	41	50.0/28.8	43.3/25.0	21.7/12.5



Light Duty with Terminal Block (ELD-TB Series)

Flexible Design for a Variety of Light Duty Applications

- 30 - 119.9-Gallon models
- 208/240/277/480 Voltages available on all models
- 3 kW - 12.1 kW Available on 30 - 50-gallon models
- 66, 80 and 119.9-Gallon models only available in 12.1 kW
- Available in short models
- Factory shipped in simultaneous configuration

Terminal Block

- Easy to convert standard models from simultaneous to non-simultaneous, single phase to three phase
- Field convertible to meet any light-duty application need
- Available on 30 - 119.9-gallon models

Energy Efficient Design

- Reduces energy consumption & standby heat loss with 2-1/2" of rigid polyurethane foam insulation

Designed for Long Life & Top Performance

- Proprietary protective steel formulation with a unique coat of high temperature porcelain enamel
- Design maximizes corrosion resistance & life of anode rod
- Patented corrosion-resistant elements include double layer of magnesium oxide and copper to resist corrosion
- Durable factory-installed full flow brass drain valve
- Low lead compliant

Automatic Temperature Control

- Automatic Temperature Control - Surface mounted thermostat automatically cycles on and off to maintain desired water temperature
- 170°F Maximum temperature setting

Warranty

- 3-Year limited tank warranty, upgradable to 5-years and 1-year on parts*

*See Commercial Warranty Certificate for complete information

These products are design certified by Underwriters Laboratories (UL) to meet UL safety standards as electric storage tank water heaters. All models are North Carolina and Massachusetts Code compliant.



These Light Duty models are available with terminal block in both fused and non-fused configurations. All water heaters with power requirements over 48 Amps come standard in the fused configuration.



DIMENSIONAL INFORMATION (All dimensions shown in English and Metric)													FIRST HOUR DEL. G.P.H.	UNIFORM ENERGY FACTOR (UEF)
MODEL NUMBER	MIN. WATTS	MAX. WATTS	TANK CAPACITY (LISTED)		TANK CAPACITY (MEASURED)		A		B		APPROX. SHIPPING WT.			
			GAL.	LTR	GAL.	LTR	INCHES	MM	INCHES	MM	lbs.	kgs.		
ELD30-TB	3,000	12,000	30	114	27	102	47-1/2	1207	19	483	125	57	46	0.92
ELD40-TB	3,000	12,000	40	151	36	136	48-1/4	1226	20-1/4	514	140	64	55	0.93
ELD52-TB	3,000	12,000	50	189	45	170	58-5/8	1489	20-1/4	514	155	70	63	0.93
ELD66-TB	12,100	12,100	65	246	58.5	221	59-3/8	1508	22-1/4	565	185	84	N/A	N/A
ELD80-TB	12,100	12,100	80	303	72	273	59-5/8	1514	23-3/4	603	220	100	N/A	N/A
ELD120-TB	12,100	12,100	119.9	454	108	409	62-7/8	1597	28-1/4	718	335	152	N/A	N/A
ELDS30-TB	3,000	12,000	28	106	25	95	30	762	23	584	130	59	43	0.92
ELDS40-TB	3,000	12,000	36	136	33	125	31-1/2	800	24-1/4	616	150	68	46	0.92
ELDS52-TB	3,000	12,000	47	178	43	163	32	813	26-1/4	667	180	82	57	0.93

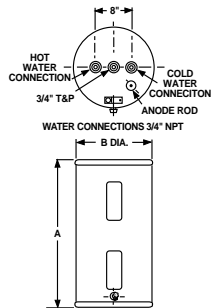

PRODUCT AVAILABILITY		Electric Light Duty models are available with terminal block in both fused and non-fused configurations. Fused configuration is Standard in all water heaters with power requirements over 48 Amps.																						
	SIZE	208V					240V					277V					480V							
		3/3	4/4	4.5/4.5	5/5	6/6	3/3	4/4	4.5/4.5	5/5	6/6	3/3	4/4	4.5/4.5	5/5	6/6	3/3	4/4	4.5/4.5	5/5	6/6			
SIM OR NON-SIM	30	✓	✓	✓	✓	✓	✓	✓	✓	✓	✓	✓	✓	✓	✓	✓	✓	✓	✓	✓	✓	✓		
	40	✓	✓	✓	✓	✓	✓	✓	✓	✓	✓	✓	✓	✓	✓	✓	✓	✓	✓	✓	✓	✓		
	50	✓	✓	✓	✓	✓	✓	✓	✓	✓	✓	✓	✓	✓	✓	✓	✓	✓	✓	✓	✓	✓	✓	
	66					✓					✓				✓							✓		
	80					✓					✓				✓								✓	
	120					✓					✓				✓								✓	

- Fused or Non-Fused, Fused if > 48 Amps • Terminal Block allows for conversions from Simultaneous element usage to non-Simultaneous for maximum energy savings.
- ELD-C Models 66/80/120 still available without terminal block. • All models are factory shipped with sim configuration.



Point-of-Use (EGSP Series)

Features

- 2-1/2, 6, 10, 15, 19.9 and 30-Gallon capacities
- 1440 Watts through 6,000 Watts
- 120, 208, 240, 277 and 480 Voltages
- Single phase only
- Premium grade anode rod provides advanced technology and equalizes aggressive water action
- Rigid polyurethane foam insulation provides superior insulating qualities resulting in reduced operating costs
- A surface mounted thermostat automatically cycles on and off to maintain the water temperature at a desired preset level
- 170 degrees Fahrenheit maximum temperature setting (except 2-1/2 gallon model)
- Temperature limiting control
- Temperature and pressure relief valve
- Low lead compliant

Long Life Tank Design

- Proprietary steel formulation with a unique coat of high temperature porcelain enamel
- Maximizes corrosion resistance resulting in a superior tank design

Long Life Heating Elements

- Patented resistor elements are designed with a specially treated, double layer of magnesium oxide and copper to resist corrosion

Warranty

- 3-Year limited tank warranty, upgradable to 5-years*

*See Commercial Warranty Certificate for complete information

These models meet the minimum energy factor requirements of ASHRAE (Part of the Federally mandated Energy Policy Act (EPact)). Also exceeds energy codes of all states including California Energy Commission (CEC). All models are North Carolina and Massachusetts Code compliant.

NEW UL Approved Electric Conversion Kits*

- Provides an easy way to convert standard models to different wattages, volt or phase depending on installation requirements
- Kits are designed for EGSP models in all gallon capacities
- All parts needed for the electric conversion are included with Rheem electric conversion kits
- Rheem electric conversion kits provide convenience for contractors, plumbers and installers which saves time and money

* Not available in Canada.

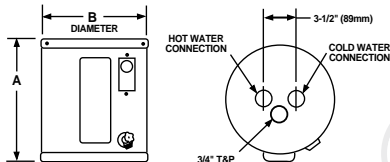

Model: EGSP2

Water Connections: 1/2" NPT



2000
PROCLUB
POINTS

ELITEXPRESS
48 HOUR
DELIVERY

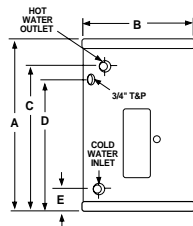

Models:
EGSP6, EGSP10,
EGSP15, EGSP20,
EGSP30

Water Connections:
3/4" NPT

DIMENSIONAL INFORMATION (All dimensions shown in inches)									
MODEL NUMBER	MIN. WATTS	MAX. WATTS	GAL. CAP.	A	B	C	D	E	APPROX. SHIP. WT. (LBS)
EGSP2	1,440	1,500	2-1/2	14	9-3/4	—	—	—	18
EGSP6	1,500	6,000	6	15-1/8	15-3/4	12-5/8	11-5/8	4-1/4	41
EGSP10	1,500	6,000	10	22-7/8	15-3/4	20-3/8	19-3/8	4-1/4	53
EGSP15	1,500	6,000	15	24-1/4	17-3/4	21-7/8	19-3/8	4-5/8	65
EGSP20	1,500	6,000	19.9	25-1/8	19-3/4	22-5/8	19-5/8	5-1/8	76
EGSP30	1,500	6,000	30	32	22-1/4	23	23	3	115

Basic model numbers are listed. When ordering specify electrical input to determine specific model number:
 Basic Model: EGSP6 Specified Input: 6,000 Watts Specified Model Number: EGSP6-6
 Use CEGSP Prefix for Canadian Models.

WATER TEMPERATURE RATINGS			
THERMOSTAT TYPE	MIN. DELIVERED TEMP.	MAX. DELIVERED TEMP.	HIGH TEMP. LIMIT
SURFACE	110° F	170° F	190° F

ELEMENT AVAILABILITY					
WATTAGE	120 V	208 V	240 V	277 V	480 V
1,440	**Y	N/A	N/A	N/A	N/A
1,500	Y	Y	**Y	N/A	N/A
2,000	Y	Y	Y	Y	Y
2,500	Y	Y	Y	N/A	N/A
3,000	Y	Y	Y	Y	Y
4,500	N/A	Y	*Y	*Y	*Y
6,000	N/A	Y	Y	Y	Y

*Not available in EGSP6 & EGSP10
 **EGSP2 available only in these configurations

ELECTRICAL CHARACTERISTICS					
ELEMENT WATTAGE	FULL LOAD CURRENT IN AMPERES				
	120 V	208 V	240 V	277 V	480 V
1,440	12.0	N/A	N/A	N/A	N/A
1,500	12.5	7.2	6.3	N/A	N/A
2,000	16.7	9.6	8.3	7.2	4.2
2,500	20.8	12.0	10.4	N/A	N/A
3,000	25.0	14.4	12.5	10.8	6.3
4,500	N/A	21.6	18.8	16.2	9.4
6,000	N/A	28.8	25.0	21.7	12.5

ELECTRICAL CHARACTERISTICS						
ELEMENT WATTAGE	TEMPERATURE RISE - DEGREES F - GALLONS PER HOUR					
	40° F	60° F	80° F	100° F	120° F	140° F
1,440	15	10	7	6	5	4
1,500	15	10	8	6	5	4
2,000	20	14	10	8	7	6
2,500	25	17	13	10	8	—
3,000	30	20	15	12	10	9
4,500	46	30	23	18	15	13
6,000	61	41	30	24	20	17



Storage Tanks (ST Series)

Features

- 80, 115 and 175-Gallon capacities
- Unique steel formulation with high temperature porcelain enamel maximizes corrosion resistance and results in a superior tank design
- Heavy duty magnesium anode rod(s) installed for longer life
- Rigid 2" polyurethane foam insulation provides superior insulating qualities and results in reduced operating costs
- Our patented process of injecting foam into the insulating cavity adds additional durability and toughness to the baked enamel steel outer jacket
- Circulating line connections and hot outlet are 2" NPT on the ST80 and ST120 and 2-1/2" NPT on the ST175
- Other openings are provided for relief valve and temperature control. ST175 equipped with a hand-hole cleanout
- All commercial storage tank models are certified to ASME boiler and pressure vessel code standards
- Low lead compliant

Warranty

- 5-Year limited tank warranty

*See Commercial Warranty Certificate for complete information

These models exceed the minimum efficiency requirements of ASHRAE (Part of the Federally mandated Energy Policy Act (EPact)).



Vertical models designed for applications that require large quantities of potable hot water in short periods of time.



TANK INFORMATION AND DIMENSIONAL INFORMATION (All dimensions shown in inches)											
MODEL NUMBER	GAL. CAP.	A	B	C	D	WATER CONNECTIONS		APPROX. SHIP. WT. (LBS)		MAX. WORKING PRESSURE	
						TOP OUTLET	FRONT SIDE	STANDARD	ASME	STANDARD	ASME
ST80(A)	80	58-5/16	24-3/16	13-3/16	6-3/16	2	2	220	260	150 PSI	125 PSI
ST120(A)	115	59-1/4	28-1/4	11-1/16	4-1/16	2	2	300	340	150 PSI	160 PSI
ST175(A)	175	67-1/4	32-1/4	12-9/16	5-9/16	2-1/2	2-1/2	600	600	150 PSI	150 PSI

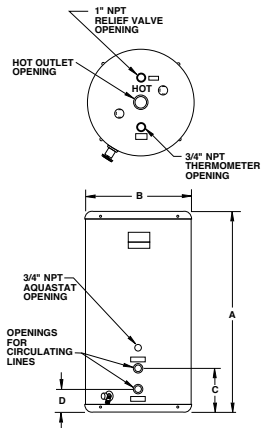

Large Volume Storage Tanks (ST, STU Series)

Features

- 200, 260, 320, 430, 500, 750 and 950-Gallon capacities
- Unique steel formulation with high temperature porcelain enamel maximizes corrosion resistance and results in a superior tank design
- Heavy duty magnesium anode rod(s) installed for longer life
- Rigid 2" polyurethane foam insulation provides superior insulating qualities and results in reduced operating costs
- Our patented process of injecting foam into the insulating cavity adds additional durability and toughness to the baked enamel steel outer jacket
- Circulating line/cold inlet connections are 3" NPT (2-1/2" on 200 gallon) and hot outlet is 2"
- All commercial storage tank models are certified to ASME boiler and pressure vessel code standards
- Low lead compliant

Warranty

- 5-Year limited tank warranty*

*See Commercial Warranty Certificate for complete information

Jacketed models meet or exceed the minimum efficiency requirements of ASHRAE (Part of the Federally mandated Energy Policy Act (EPact))



TANK INFORMATION		
MODEL NUMBER	GALLON CAPACITY	MAXIMUM WORKING PRESSURE ASME
ST(U)200A	200	150 PSI
ST(U)260A	257	125 PSI
ST(U)320A	318	125 PSI
ST(U)430A	432	125 PSI
ST(U)500A	504	125 PSI
ST(U)750A	752	125 PSI
ST(U)950A	940	125 PSI

Jacketed and non-jacketed vertical models designed for applications that require large quantities of potable hot water in short periods of time.



DIMENSIONAL INFORMATION FOR VERTICAL ROUND JACKETED STORAGE TANKS (All dims. shown in inches)

MODEL NUMBER	A	B	C	D	WATER CONNECTIONS		APPROX. SHIP. WT. (LBS)
					TOP OUTLET	FRONT SIDE	
ST200A	79-1/2	34	13-3/16	18-3/16	2-1/2	2-1/2	872
ST260A	95-1/2	34	18	26	2	3	1108
ST320A	84-1/2	40	19-3/4	27-1/4	2	3	1290
ST430A	84-1/2	46	21	29	2	3	1626
ST500A	94-1/2	46	21	29	2	3	1765
ST750A	107-1/2	54	22-7/8	30-7/8	2	3	2330
ST950A	131-1/2	54	22-7/8	30-7/8	2	3	3010

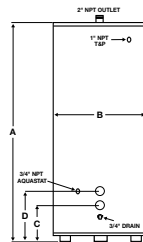

For model ST200A only.

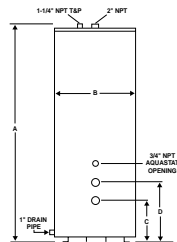

For ST260A, ST320A, ST430A, ST500A, ST750A and ST950A models.

DIMENSIONAL INFORMATION FOR VERTICAL BARE (NON-JACKETED) STORAGE TANKS (All dims. shown in inches)

MODEL NUMBER	A	B	C	D	WATER CONNECTIONS		APPROX. SHIP. WT. (LBS)
					TOP OUTLET	FRONT SIDE	
STU200A	75-3/4	30	10-15/16	18-7/16	2-1/2	2-1/2	488
STU260A	88	30	15-3/4	23-3/4	2	3	464
STU320A	76	36	17-3/8	25-3/8	2	3	574
STU430A	76	42	18-7/8	26-7/8	2	3	816
STU500A	88	42	18-7/8	26-7/8	2	3	925
STU750A	100	48	20-7/8	28-7/8	2	3	1387
STU950A	124	48	20-7/8	28-7/8	2	3	1651

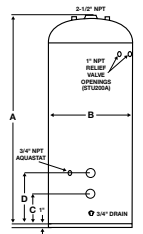

For model STU200A only.

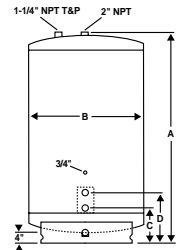

For STU260A, STU320A, STU430A, STU500A, STU750A and STU950A models.



CertiSpec Web

**No downloading software!
CertiSpec now has easy online
access through the web.**

New Features:

- Access through www.rheem.com
- Fuel cost calculator
- Link directly to Spec Sheets, Use & Care Manuals, Brochures and Revit Models

Computer Requirements:

- Internet connection required



American						Rheem-Ruud					
Model	BTU/h	Gal.	Efficiency*	Dia.	Height	Model	BTU/h	Gal.	Efficiency*	Dia.	Height
Gas Tank Type – Atmospheric											
CFG32-50T50-4NOV	50,000	50	n/a	22"	60-1/4"	G50-60N	60,000	48	n/a	21-3/4"	61-3/4"
CG32-75T75-4NV	75,100	75	n/a	26"	63-1/2"	G75-75N-2	75,100	75	80%	26-1/4"	64"
CG32-100T77-4NOV	75,100	98	n/a	26-1/2"	69-3/4"	G100-80	80,000	98	80%	28-1/4"	69-5/8"
Gas Tank Type – Atmospheric Dampened											
BCG3-70T120-5N	120,000	71	80%	27-3/4"	69-3/4"	G75-125	125,000	75	80%	26-1/4"	65-1/2"
BCG3-80T150-6N	154,000	81	80%	27-3/4"	73"	G82-156	156,000	82	80%	26-1/4"	68-13/16"
BCG3-80T180-6N	180,000	81	80%	27-3/4"	67-1/2"	G76-180	180,000	76	80%	26-1/4"	68-13/16"
BCG3-80T199-6N	199,000	81	80%	27-3/4"	67-1/2"	G91-200	199,900	91	80%	26-1/4"	76-5/8"
BCG3-100T199-8N	199,000	100	80%	27-3/4"	75"	G91-200	199,900	91	80%	26-1/4"	76-5/8"
BCG3-100T200-8N	199,000	100	80%	30-1/4"	72"	G100-200(A)	199,900	100	80%	30-1/4"	73-1/16"
BCG3-100T250-8N	250,000	100	80%	30-1/4"	72"	G100-250(A)	250,000	100	80%	30-1/4"	73-1/4"
BCG3-65T250-8N	251,000	65	80%	27-3/4"	75"	G72-250(A)	250,000	72	80%	26-1/4"	71-1/16"
BCG3-100T275-8N	275,000	100	80%	30-1/4"	72"	G100-270(A)	270,000	100	80%	30-1/4"	73-7/8"
BCG3-65T300-8N	305,000	65	80%	27-3/4"	75"	G72-300(A)	300,000	72	80%	26-1/4"	71"
BCG3-85T360-8N	365,000	85	80%	27-3/4"	79-1/2"	G65-360(A)	360,000	65	80%	26-1/4"	70-11/16"
BCG3-100T390-8N	399,000	100	80%	30-1/4"	75-1/2"	G100-400(A)	399,900	100	80%	30-1/4"	76"
BCG3-85T500-8N	500,000	85	80%	27-3/4"	82-1/4"	GX90-550(A)	550,000	90	80%	30"	74-1/2"
Gas Tank Type – Atmospheric, Low NOx Emission Compliant											
BCG3-70T120-6NOX	120,000	71	82%	27-3/4"	63"	GN75-125	125,000	75	80%	26-1/4"	65-1/2"
BCG3-80T150-6NOX	154,000	81	80%	27-3/4"	68"	GN82-156	156,000	82	80%	26-1/4"	68-13/16"
BCG3-100T180-6NOX	180,000	100	80%	27-3/4"	72"	GN76-200	199,900	76	80%	26-1/4"	68-13/16"

American						Rheem-Ruud					
Model	BTU/h	Gal.	Efficiency*	Dia.	Height	Model	BTU/h	Gal.	Efficiency*	Dia.	Height
Gas Tank Type – Atmospheric, Low NOx Emission Compliant Continued											
BCG3-95T199-6NOX	199,000	93	82%	27-3/4"	72"	GN91-200	199,900	91	80%	26-1/4"	76-5/16"
BCG3-100T199-6NOX	199,000	100	80%	27-3/4"	72"	GN91-200	199,900	91	80%	26-1/4"	76-5/16"
BCG3-100T200-6NOX	199,000	100	80%	27-3/4"	72"	GN100-200(A)	199,900	100	80%	30-1/4"	73-1/16"
BCG3-100T250-6NOX	250,000	100	80%	27-3/4"	72"	GN100-250(A)	250,000	100	80%	30-1/4"	73-1/4"
BCG3-100T275-6NOX	275,000	100	80%	27-3/4"	72"	GN100-270(A)	270,000	100	80%	30-1/4"	73-7/8"
BCG3-85T366-6NOX	366,000	85	80%	27-3/4"	73"	GN65-360(A)	360,000	65	80%	26-1/4"	70-11/16"
BCG3-85T390-6NOX	390,000	85	80%	27-3/4"	73"	GN100-400(A)	399,900	100	80%	30-1/4"	76"
Gas Tank Type – Atmospheric, Ultra Low NOx Emission Compliant											
BBCN3 75T75 NV	75,100	74	80%	25-1/4"	65-7/8"	G75UN	75,100	75	80%	26-1/4"	64-1/8"
BCN3 100T75NV	75,100	98	80%	27-3/4"	70-1/2"	G100UN	75,100	98	80%	27-1/8"	67-7/8"
BCL3-80T120-6NOX	120,000	81	82%	27-3/4"	68-1/4"	GNU75-125	125,000	75	80%	26-1/4"	65-1/2"
BCL3-80T154-6NOX	154,000	81	82%	27-3/4"	68-1/4"	GNU82-156	156,000	82	80%	26-1/4"	68-13/16"
BCL3-95T180-6NOX	180,000	93	82%	27-3/4"	76"	GNU76-200	199,900	76	80%	26-1/4"	68-13/16"
BCL3-95T199-6NOX	199,000	93	82%	27-3/4"	76"	GNU91-200	199,900	91	82%	26-1/4"	76-5/16"
(A)BCL3-95T250-6NOX	250,000	93	82%	27-3/4"	76"	GNU100-250(A)	250,000	100	80%	30-1/4"	73-1/4"
(A)BCL3-85T275-6NOX	275,000	85	82%	27-3/4"	76"	GNU100-270(A)	270,000	100	82%	30-1/4"	73-7/8"
(A)BCL3-85T366-6NOX	366,000	85	82%	27-3/4"	76"	GNU65-360(A)	360,000	65	80%	26-1/4"	70-11/16"
(A)BCL3-85T390-6NOX	399,000	85	82%	27-3/4"	76"	GNU100-400(A)	399,900	100	80%	30-1/4"	76"
Gas Tank Type – Power Vented											
PVCG32-75T75-3N	70,000	75	80%	26"	70-1/4"	GPV75-75FV-2	75,100	75	80%	26-1/4"	72"

*Based on ANSI Z21.10.3 Thermal Efficiency Test.

American						Rheem-Ruud					
Model	BTU/h	Gal.	Efficiency*	Dia.	Height	Model	BTU/h	Gal.	Efficiency*	Dia.	Height
Gas Tank Type – Power Direct Vented, Fully Condensing, Stainless Steel Tank & Heat Exchanger											
PGC3 34-130-2NV	130,000	34	96%	22"	48-1/2"	HE55-130	130,000	55	95%	23-1/2"	52"
PGC3 34-150-2NV	150,000	34	95%	22"	48-1/2"	HE55-160	160,000	55	95%	23-1/2"	52"
PGC3 50-130-3NV	130,000	50	95%	22"	62-1/2"	HE55-130	130,000	55	95%	23-1/2"	52"
PGC3 50-150-3NV	150,000	50	95%	22"	62-1/2"	HE55-160	160,000	55	95%	23-1/2"	52"
PGC3 50-175-3NV	175,000	50	95%	22"	63-3/4"	HE55-199	199,000	55	95%	23-1/2"	52"
PGC3 50-199-3NV	199,000	50	95%	22"	63-3/4"	HE55-199	199,000	55	95%	23-1/2"	52"
Gas Tank Type – Power Direct Vented, Fully Condensing, Porcelain Coated Tank & Heat Exchange											
(A)HCG3-60T120-3N	120,000	60	95%	27-3/4"	55-1/2"	GHE80SS-130	130,000	80	98%	26-3/8"	67-7/8"
						GHE80SU-130					
(A)HCG3-100T150-3N	150,000	100	95%	27-3/4"	75-1/2"	GHE100SS-160(A)	160,000	100	97%	26-3/8"	77"
						GHE100SU-160(A)					
(A)HCG3-100T199-3N	199,000	100	95%	27-3/4"	75-1/2"	GHE100SS-200(A)	199,000	100	97%	26-3/8"	77"
						GHE100SU-200(A)					
(A)HCG3-100T250-3N	250,000	100	95%	27-3/4"	75-1/2"	GHE100SS-250(A)	250,000	100	98%	26-3/8"	77"
						GHE100SU-250(A)					
(A)HCG3-100T300-3N	300,000	130	96%	33-1/8"	75-1/2"	GHE100SS-300(A)	300,000	100	96%	26-3/8"	77"
						GHE100SU-300(A)					
(A)HCG3-100T400-3N	399,900	130	95%	33-1/8"	75-1/2"	GHE100SS-400(A)	399,900	100	95%	26-3/8"	77"
						GHE100SU-400(A)					

*Based on ANSI Z21.10.3 Thermal Efficiency Test.

American						Rheem-Ruud					
Model	Kw	Gal.	Efficiency**	Dia.	Height	Model	Kw	Gal.	Efficiency**	Dia.	Height
Electric Tank-Type – Point-of-Use											
LDCE31-06U	4.5 max	6	98%	14-1/4"	16-7/8"	EGSP6	6 max	6	98%	15-3/4"	15-1/8"
LDCE31-12U	5.5 max	12	98%	16"	22-3/4"	EGSP10	6 max	10	98%	15-3/4"	22-7/8"
LDCE31-19U	6 max	19	98%	18"	25"	EGSP20	6 max	19.9	98%	19-3/4"	25-1/8"
Electric Tank-Type – Light Duty											
LDCE32-30L	12 max	30	98%	22"	29-1/2"	ELDS30	12 max	30	98%	22-1/4"	30"
LDCE32-40L	12 max	40	98%	24"	31-5/8"	ELDS40	12 max	40	98%	23"	31-1/2"
LDCE32-50L	12 max	50	98%	26"	31-5/8"	ELDS52	12 max	50	98%	26-1/4"	32"
LDCE32-30H	12 max	30	98%	18"	45-1/4"	ELD30	12 max	30	98%	19-1/4"	47-1/2"
LDCE32-40R	12 max	40	98%	20"	47-1/4"	ELD40	12 max	40	98%	20-1/4"	48-1/8"
LDCE32-50R	12 max	50	98%	22"	47-3/4"	ELD52	12 max	50	98%	20-1/4"	58-1/2"
LDCE32-65H	12 max	66	98%	22"	59-1/4"	ELD66	12 max	66	98%	22-1/4"	59-3/8"
LDCE32-80H	12 max	80	98%	24"	59-1/4"	ELD80	12 max	80	98%	23-3/4"	59-1/2"
LDCE32-119R	12 max	119	98%	28"	61-1/2"	ELD120	12 max	119	98%	28-1/4"	62-7/8"
Electric Tank-Type – Heavy Duty											
STCE/ITCE31-50	54 max	50	98%	21-3/4"	55-3/4"	ES/E50	54 max	50	98%	26-1/4"	43-5/8"
STCE/ITCE31-80	54 max	80	98%	25-1/2"	60-1/4"	ES/E85	81 max	85	98%	28-1/4"	57-11/16"
STCE/ITCE31-119	54 max	119	98%	29-1/2"	62-1/4"	ES/E120	81 max	119	98%	30-1/4"	67-5/8"

**Accepted heat transfer efficiency of immersion heating elements.

A. O. Smith						Rheem-Ruud					
Model	BTU/h	Gal.	Efficiency*	Dia.	Height	Model	BTU/h	Gal.	Efficiency*	Dia.	Height
Gas Tank Type – Atmospheric											
BT-60	60,000	55	80%	24"	59-3/4"	G50-60N	60,000	48	80%	21-3/4"	61-3/4"
BT-80	75,100	74	80%	26-1/2"	61-1/8"	G75-75N-3	75,100	75	80%	26-1/4"	64"
BT-100	75,100	98	80%	27-3/4"	68-5/8"	G100-80N	80,000	100	80%	28-1/4"	69-5/8"
Gas Tank Type – Atmospheric Dampered											
BTR-120	120,000	71	80%	27-3/4"	69-3/4"	G75-125	125,000	75	80%	26-1/4"	65-1/2"
BTR-154	154,000	81	80%	27-3/4"	73"	G82-156	156,000	82	80%	26-1/4"	68-13/16"
BTR-180	180,000	81	80%	27-3/4"	67-1/2"	G76-180	180,000	76	80%	26-1/4"	68-13/16"
BTR-197	199,000	100	80%	27-3/4"	75"	G91-200	199,900	91	80%	26-1/4"	76-5/8"
BTR-198	199,000	100	80%	27-3/4"	75"	G91-200	199,900	91	80%	26-1/4"	76-5/8"
BTR-199	190,000	81	80%	27-3/4"	67-1/2"	G76-200	199,900	76	80%	26-1/4"	68-13/16"
BTR-200(A)	199,000	100	80%	30-1/4"	72"	G100-200(A)	199,900	100	80%	30-1/4"	73-1/16"
BTR-201(A)	199,900	32	80%	27-3/4"	45"	G37-200	199,900	35	80%	26-1/4"	49-1/4"
BTR-250(A)	250,000	100	80%	30-1/4"	72"	G100-250(A)	250,000	100	80%	30-1/4"	73-1/4"
BTR-251(A)	251,000	65	80%	27-3/4"	75"	G72-250(A)	250,000	72	80%	26-1/4"	71-1/16"
BTR-275(A)	275,000	100	80%	30-1/4"	72"	G100-270(A)	270,000	100	80%	30-1/4"	73-7/8"
BTR-305(A)	305,000	65	80%	27-3/4"	75"	G72-300(A)	300,000	72	80%	26-1/4"	71"
BTR-365(A)	365,000	85	80%	27-3/4"	79-1/2"	G65-360(A)	360,000	65	80%	26-1/4"	70-11/16"
BTR-400(A)	399,000	100	80%	30-1/4"	75-1/2"	G100-400(A)	399,900	100	80%	30-1/4"	76"
BTR-500(A)	500,000	85	80%	27-3/4"	82-1/4"	GX90-550(A)	550,000	90	80%	30"	74-1/2"
Gas Tank Type – Atmospheric, Low NOx Emission Compliant											
BT-60	60,000	55	80%	24"	59-3/4"	G50-60N	60,000	48	80%	21-3/4"	61-3/4"
BT-80	75,100	74	80%	26-1/2"	61-1/8"	G75-75N-3	75,100	75	80%	26-1/4"	64"
BT-100	75,100	98	80%	27-3/4"	68-5/8"	G100-80N	76,000	100	80%	28-1/4"	69-5/8"

A. O. Smith						Rheem-Ruud					
Model	BTU/h	Gal.	Efficiency*	Dia.	Height	Model	BTU/h	Gal.	Efficiency*	Dia.	Height
Gas Tank Type – Atmospheric, Low NOx Emission Compliant Continued											
BTN-120	120,000	71	80%	27-3/4"	63"	GN75-125	125,000	75	80%	26-1/4"	65-1/2"
BTN-154	154,000	81	80%	27-3/4"	68"	GN82-156	156,000	82	80%	26-1/4"	68-13/16"
BTN-180	180,000	100	80%	27-3/4"	72"	GN76-200	199,900	76	80%	26-1/4"	68-13/16"
BTN-199C	199,000	100	82%	27-3/4"	72"	GN91-200	199,900	91	80%	26-1/4"	76-5/16"
BTN-199	199,000	100	80%	27-3/4"	72"	GN91-200	199,900	91	80%	26-1/4"	76-5/16"
BTN-200(A)	199,000	100	80%	27-3/4"	72"	GN100-200(A)	199,900	100	80%	30-1/4"	73-1/16"
BTN-250(A)	250,000	100	80%	27-3/4"	72"	GN100-250(A)	250,000	100	80%	30-1/4"	73-1/4"
BTN-270(A)	275,000	100	80%	27-3/4"	72"	GN100-270(A)	270,000	100	80%	30-1/4"	73-7/8"
BTN-366(A)	366,000	85	80%	27-3/4"	73"	GN65-360(A)	360,000	65	80%	26-1/4"	70-11/16"
BTN-400(A)	390,000	85	80%	27-3/4"	73"	GN100-400(A)	399,900	100	80%	30-1/4"	76"
Gas Tank Type – Atmospheric, Ultra Low NOx Emission Compliant											
BL-80	75,100	74	80%	25-1/4"	62-1/16"	G75UN	75,100	75	80%	26-1/4"	64-1/8"
BL-100	75,100	98	80%	27-3/4"	70-1/2"	G100UN	75,100	98	80%	27-1/8"	67-7/8"
BTL-120	120,000	81	82%	27-3/4"	65"	GNU75-125	125,000	75	80%	26-1/4"	65-1/2"
BTL-154	154,000	81	82%	27-3/4"	65"	GNU82-156	156,000	82	80%	26-1/4"	68-13/16"
BTL-180	180,000	81	82%	27-3/4"	65"	GNU76-200	199,900	76	80%	26-1/4"	68-13/16"
BTL-199	199,000	100	82%	27-3/4"	73"	GNU91-200	199,900	91	82%	26-1/4"	76-5/16"
BTL-250(A)	250,000	100	82%	27-3/4"	73"	GNU100-250(A)	250,000	100	80%	30-1/4"	73-1/4"
BTL-275(A)	275,000	100	82%	27-3/4"	73"	GNU100-270(A)	270,000	100	82%	30-1/4"	73-7/8"
BTL-366(A)	366,000	86	82%	27-3/4"	73"	GNU65-360(A)	360,000	65	80%	26-1/4"	70-11/16"
BTL-400(A)	399,000	86	82%	27-3/4"	73"	GNU100-400(A)	399,900	100	80%	30-1/4"	76"

*Based on ANSI Z21.10.3 Thermal Efficiency Test.

A. O. Smith						Rheem-Ruud					
Model	BTU/h	Gal.	Efficiency*	Dia.	Height	Model	BTU/h	Gal.	Efficiency*	Dia.	Height
Gas Tank-Type – Power Direct Vented (2 pipe)											
BPD-80	76,000	75	80%	26"	70-5/8"	GPDV75-75	75,100	75	80%	26-1/2"	70-3/8"
Gas Tank-Type – Power Direct Vented, Fully Condensing											
BTX-100	100,000	50	96%	22"	66-3/4"	HE55-100	100,000	55	95%	23-1/2"	52"
BTXL-100	100,000	75	96%	27-3/4"	65-1/4"	GHE80SS-130	130,000	80	98%	26-3/8"	67-7/8"
						GHE80SU-130					
BTH-120(A)	120,000	60	95%	27-3/4"	55-1/2"	GHE80SS-130(A)	130,000	80	98%	26-3/8"	67-7/8"
						GHE80SU-130(A)					
BTH-150(A)	150,000	100	95%	27-3/4"	76-1/2"	GHE100SS-160(A)	160,000	100	97%	26-3/8"	77"
						GHE100SU-160(A)					
BTH-199(A)	199,000	100	95%	27-3/4"	76-1/2"	GHE100SS-200(A)	199,000	100	97%	26-3/8"	77"
						GHE100SU-200(A)					
BTH-250(A)	250,000	100	95%	27-3/4"	76-1/2"	GHE100SS-250(A)	250,000	100	98%	26-3/8"	77"
						GHE100SU-250(A)					
BTH-300(A)	300,000	119	96%	33-1/8"	75-3/4"	GHE100SS-300(A)	300,000	100	96%	26-3/8"	77"
						GHE100SU-300(A)					
BTH-400(A)	399,900	119	95%	33-1/8"	75-3/4"	GHE100SS-400(A)	399,900	100	95%	26-3/8"	77"
						GHE100SU-400(A)					
BTH-500	499,900	119	95%	33-1/8"	75-3/4"	GHE119-500	500,000	119	93%	32"	78-1/2"
BTH-500A	499,900	119	95%	33-1/8"	75-3/4"	GHE125-500A	500,000	125	93%	32"	78-1/2"

*Based on ANSI Z21.10.3 Thermal Efficiency Test.

A. O. Smith						Rheem-Ruud					
Model	Kw	Gal.	Efficiency**	Dia.	Height	Model	Kw	Gal.	Efficiency**	Dia.	Height
Electric Tank-Type – Point-of-Use											
DEL-6 S	2.5 max	6	98%	14-1/4"	15-1/2"	EGSP6	6 max	6	98%	15-3/4"	15-1/8"
DEL-10 S	6 max	10	98%	18"	18-1/4"	EGSP10	6 max	10	98%	15-3/4"	22-7/8"
DEL-15 S	6 max	15	98%	18"	26"	EGSP15	6 max	15	98%	17-3/4"	24-1/4"
DEL-20 S	6 max	19.9	98%	21-3/4"	22-1/4"	EGSP20	6 max	19.9	98%	19-3/4"	25-1/8"
Electric Tank-Type – Light Duty											
DEL-30 D	12 max	30	98%	21-3/4"	30-7/8"	ELDS30	12 max	30	98%	22-1/4"	30"
DEL-40 D	12 max	40	98%	24"	32-1/4"	ELDS40	12 max	40	98%	23"	31-1/2"
DEL-52 D	12 max	50	98%	26-1/2"	32-1/4"	ELDS52	12 max	50	98%	26-1/4"	32"
DEN-30 D	12 max	30	98%	20-1/2"	34-1/2"	ELD30	12 max	30	98%	19-1/4"	47-1/2"
DEN-40 D	12 max	40	98%	20-1/2"	45-1/8"	ELD40	12 max	40	98%	20-1/4"	48-1/8"
DEN-52 D	12 max	50	98%	20-1/2"	54-7/8"	ELD52	12 max	50	98%	20-1/4"	58-1/2"
DEN-66 D	12 max	66	98%	21-3/4"	60-3/4"	ELD66	12 max	66	98%	22-1/4"	59-3/8"
DEN-80 D	12 max	80	98%	24"	59-3/8"	ELD80	12 max	80	98%	23-3/4"	59-1/2"
DEN-120 D	12 max	119	98%	29-3/8"	62-7/16"	ELD120	12 max	119	98%	28-1/4"	62-7/8"
Electric Tank-Type – Heavy Duty											
DRE/DVE-52	54 max	50	98%	21-3/4"	55-3/4"	ES/E50	54 max	50	98%	26-1/4"	43-5/8"
DRE/DVE-80	54 max	80	98%	25-1/2"	60-1/4"	ES/E85	81 max	85	98%	28-1/4"	57-11/16"
DRE/DVE-120	54 max	119	98%	29-1/2"	62-1/4"	ES/E120	81 max	119	98%	30-1/4"	67-5/8"
DSE-10	6 max	10	98%	18-3/4"	26-1/4"	E12A	9 max	13	98%	19"	28-1/2"
DSE-20	18 max	20	98%	20-1/2"	27-1/4"	E20A	18 max	20	98%	19"	36-1/2"
DSE-30	24 max	30	98%	20-1/2"	35-3/4"	E30A	36 max	30	98%	19"	49-1/4"
DSE-40	36 max	40	98%	20-1/2"	45-3/4"	E40A	36 max	40	98%	21"	53-3/4"
DSE-50	90 max	50	98%	20-1/2"	54-3/4"	E50A	54 max	50	98%	26-1/4"	43-5/8"

**Accepted heat transfer efficiency of immersion heating elements.

A. O. Smith						Rheem-Ruud					
Model	Kw	Gal.	Efficiency**	Dia.	Height	Model	Kw	Gal.	Efficiency**	Dia.	Height
Electric Tank-Type – Heavy Duty Continued											
DSE-65	90 max	65	98%	26-1/2"	54"	E85A	81 max	85	98%	28-1/4"	57-11/16"
DSE-80	90 max	80	98%	28"	52-1/4"	E85A	81 max	85	98%	28-1/4"	57-11/16"
DSE-100	90 max	100	98%	28"	60-1/2"	E120A	81 max	119	98%	30-1/4"	67-5/8"
DSE-120	90 max	119	98%	30"	65-1/2"	E120A	81 max	119	98%	30-1/4"	67-5/8"
Electric Tank-Type – Dishwasher Booster											
CMC-*kW	54 max	5	98%	n/a	n/a	E10	54 max	10	98%	21-3/4"	23"
SU-*kW	54 max	20	98%	n/a	n/a	E10	54 max	10	98%	21-3/4"	23"

**Accepted heat transfer efficiency of immersion heating elements.

Bradford White						Rheem-Ruud					
Model	BTU/h	Gal.	Efficiency*	Dia.	Height	Model	BTU/h	Gal.	Efficiency*	Dia.	Height
Gas Tank Type – Atmospheric											
LG250H653N	65,000	48	n/a	22"	60"	G50-60N	60,000	48	n/a	21-3/4"	61-3/4"
LG155H803N	80,000	55	n/a	22"	59-1/2"	G75-75N-3	75,100	75	80%	26-1/4"	64"
LG275H763N	76,000	75	80%	24"	62-5/8"	G75-75N-3	75,100	75	80%	26-1/4"	64"
LG2100H853N	85,000	100	80%	28-1/4"	69"	G100-80	80,000	100	80%	28-1/4"	69-5/8"
Gas Tank Type – Atmospheric Dampered											
D-38T-155-3N	155,000	38	80%	28-1/4"	51"	G37-200	199,900	35	80%	26-1/4"	49-1/4"
D-75T-125-3N	125,000	75	80%	28-1/4"	72-1/4"	G75-125	125,000	75	80%	26-1/4"	65-1/2"
D-75T-160-3N	160,000	75	80%	28-1/4"	72-1/4"	G82-156	156,000	82	80%	26-1/4"	68-13/16"
D-80T-180-3N	180,000	80	80%	28-1/4"	71-7/8"	G76-180	180,000	76	80%	26-1/4"	68-13/16"
D-100T-199-3N	199,999	98	80%	28-1/4"	83-3/8"	G91-200	199,900	91	80%	26-1/4"	76-5/8"

Bradford White						Rheem-Ruud					
Model	BTU/h	Gal.	Efficiency*	Dia.	Height	Model	BTU/h	Gal.	Efficiency*	Dia.	Height
Gas Tank Type – Atmospheric Dampened Continued											
D-80T-199-3N	199,999	80	80%	28-1/4"	71-7/8"	G76-200	199,900	76	80%	26-1/4"	68-13/16"
D-100S-199-3N	199,999	100	80%	30-1/4"	76-3/4"	G100-200(A)	199,900	100	80%	30-1/4"	73-1/16"
D-100T-199-3N	199,999	100	80%	28-1/4"	83-3/8"	G100-200(A)	199,900	100	80%	30-1/4"	73-1/16"
D-100L-199-3N	199,999	100	80%	30-1/4"	75"	G100-200(A)	199,900	100	80%	30-1/4"	73-1/16"
D-80T-250-3N(A)	250,000	80	80%	28-1/4"	71-7/8"	G72-250(A)	250,000	72	80%	26-1/4"	71-1/16"
D-100S-250-3N(A)	250,000	100	80%	30-1/4"	76-3/4"	G100-250(A)	250,000	100	80%	30-1/4"	73-1/4"
D-100L-250-3N(A)	250,000	100	80%	30-1/4"	75"	G100-250(A)	250,000	100	80%	30-1/4"	73-1/4"
D-100L-270-3N(A)	270,000	100	80%	30-1/4"	75"	G100-270(A)	270,000	100	80%	30-1/4"	73-7/8"
D-75T-300-3N(A)	300,000	75	80%	28-1/4"	74-3/8"	G72-300(A)	300,000	72	80%	26-1/4"	71"
D-100L-300-3N(A)	300,000	100	80%	30-1/4"	75-3/8"	G100-310(A)	310,000	100	80%	26-1/4"	75"
D-65T-370-3N(A)	370,000	65	80%	28-1/4"	73-1/4"	G65-360(A)	360,000	65	80%	26-1/4"	70-11/16"
D-65T-399-3N(A)	399,999	65	80%	28-1/4"	73-1/4"	G65-399(A)	399,900	65	80%	26-1/4"	70-11/16"
D-80L-399-3N(A)	399,999	80	80%	30-1/4"	71-1/2"	G100-400(A)	399,900	100	80%	30-1/4"	76"
D-80T-425-3N(A)	425,000	80	80%	28-1/4"	82-3/4"	G85-400(A)	399,900	85	80%	26-1/4"	78-13/16"
D-80L-450-3N(A)	450,000	80	80%	30-1/4"	69"	GX90-550(A)	550,000	90	80%	30"	74-1/2"
D-80T-505-3N(A)	505,000	80	80%	28-1/4"	82-3/4"	GX90-550(A)	550,000	90	80%	30"	74-1/2"
D-80L-505-3N(A)	505,000	80	80%	30-1/4"	69"	GX90-550(A)	550,000	90	80%	30"	74-1/2"
Gas Tank Type – Atmospheric, Low NOx Emission Compliant											
75T-80B-3N	76,000	75	80%	26"	62-3/8"	G75-75N-2	75,100	75	80%	26-1/4"	64"
100T-88B-3N	88,000	100	80%	28-1/4"	69-1/8"	G100-80N	76,000	100	80%	28-1/4"	69-5/8"
D-38T-155E-3N	155,000	38	80%	28-1/4"	51"	GN37-200	199,900	35	80%	26-1/4"	49-1/4"
D-75T-125E-3N	125,000	75	80%	28-1/4"	72-1/4"	GN75-125	125,000	75	80%	26-1/4"	65-1/2"

*Based on ANSI Z21.10.3 Thermal Efficiency Test.

Bradford White						Rheem-Ruud					
Model	BTU/h	Gal.	Efficiency*	Dia.	Height	Model	BTU/h	Gal.	Efficiency*	Dia.	Height
Gas Tank Type – Atmospheric, Low NOx Emission Compliant Continued											
D-75T-160E-3N	160,000	75	80%	28-1/4"	72-1/4"	GN82-156	156,000	82	80%	26-1/4"	68-13/16"
D-80T-199E-3N	199,999	80	80%	28-1/4"	71-7/8"	GN76-200	199,900	76	80%	26-1/4"	68-13/16"
D100T-199E-3N	199,999	98	80%	28-1/4"	83-3/8"	GN91-200	199,900	91	80%	26-1/4"	76-5/16"
D-100S-199E-3N	199,999	100	80%	30-1/4"	76-3/4"	GN100-200(A)	199,900	100	80%	30-1/4"	73-1/16"
D-100L-199E-3N	199,999	100	80%	30-1/4"	75"	GN100-200(A)	199,900	100	80%	30-1/4"	73-1/16"
D-100S-250E-3N(A)	250,000	100	80%	30-1/4"	76-3/4"	GN100-250(A)	250,000	100	80%	30-1/4"	73-1/4"
D-100L-250E-3N(A)	250,000	100	80%	30-1/4"	75"	GN100-250(A)	250,000	100	80%	30-1/4"	73-1/4"
D-100S-270E-3N(A)	270,000	100	80%	30-1/4"	74-1/4"	GN100-270(A)	270,000	100	80%	30-1/4"	73-7/8"
D-100L-270E-3N(A)	270,000	100	80%	30-1/4"	75"	GN100-270(A)	270,000	100	80%	30-1/4"	73-7/8"
D-65T-370E-3N(A)	370,000	65	80%	28-1/4"	73-1/4"	GN65-360(A)	360,000	65	80%	26-1/4"	70-11/16"
D-80S-399E-3N(A)	399,999	80	80%	30-1/4"	77-1/4"	GN100-400(A)	399,900	100	80%	30-1/4"	76"
D-80L-399E-3N(A)	399,999	80	80%	30-1/4"	71-1/2"	GN100-400(A)	399,900	100	80%	30-1/4"	76"
Gas Tank Type – Atmospheric, Ultra Low NOx Emission Compliant											
ULG250H553N	55,000	48	80%	22"	60-5/16"	n/a					
ULG275H763N	76,000	75	80%	26"	64-1/8"	G75UN	75,100	75	80%	26-1/4"	64-1/8"
ULG2100H853N	85,000	100	80%	28-1/4"	69-13/16"	G100UN	75,100	98	80%	27-1/8"	67-7/8"
UCG-100H-199-3N	199,999	100	84%	28-1/4"	73-1/4"	GNU100-200(A)	199,900	100	82%	30-1/4"	73-1/16"
UCG-100H-270-3N	270,000	100	84%	28-1/4"	73-1/4"	GNU100-270(A)	270,000	100	82%	30-1/4"	73-7/8"
UCG-100H-399-3N	399,999	98	84%	28-1/4"	77-1/4"	GNU100-400(A)	399,900	100	80%	30-1/4"	76"

Bradford White						Rheem-Ruud					
Model	BTU/h	Gal.	Efficiency*	Dia.	Height	Model	BTU/h	Gal.	Efficiency*	Dia.	Height
Gas Tank-Type – Power Direct Vented, Fully Condensing											
EF-60T-125E-3N(A)	125,000	60	96%	28-1/4"	57"	GHE80SS-130	130,000	80	98%	26-3/8"	67-7/8"
						GHE80SU-130					
EF-60T-150E-3N(A)	150,000	60	93%	28-1/4"	57"	GHE100SS-160(A)	160,000	100	97%	26-3/8"	77"
						GHE100SU-160(A)					
EF-60T-199E-3N(A)	199,999	60	92%	28-1/4"	57"	GHE100SS-200(A)	199,000	100	97%	26-3/8"	77"
						GHE100SU-200(A)					
EF-100T-150E-3N(A)	150,000	100	99.1%	28-1/4"	77-5/8"	GHE100SS-250(A)	250,000	100	98%	26-3/8"	77"
						GHE100SU-250(A)					
EF-1000T-199E-3N(A)	199,999	100	98.5%	28-1/4"	77-5/8"	GHE100SS-300(A)	300,000	100	96%	26-3/8"	77"
						GHE100SU-300(A)					
EF-1000T-250E-3N(A)	250,000	100	97%	28-1/4"	77-5/8"	GHE100SS-400(A)	399,900	100	95%	26-3/8"	77"
						GHE100SU-400(A)					
EF-1000T-300E-3N(A)	300,000	100	92%	28-1/4"	77-5/8"	GHE119-500	500,000	119	93%	32"	78-1/2"
EF-1000T-399E-3N(A)	399,999	100	92%	28-1/4"	77-5/8"	GHE125-500A	500,000	125	93%	32"	78-1/2"
Gas Tank Type – Power Vented											
LG2PV75H763N	76,000	75	80%	26"	69-7/16"	GPV75-75FV-2	75,100	75	80%	26-1/4"	72"
Gas Tank-Type – Power Direct Vented (2 pipe)											
LG2PDV50H603N	60,000	48	n/a	22"	69"	GPDV50-65	65,000	50	n/a	21-3/4"	67-5/8"
LG2PDV75H803N	80,000	75	80%	26"	72"	GPDV75-75	75,100	75	80%	26-1/2"	70-3/8"

*Based on ANSI Z21.10.3 Thermal Efficiency Test.

Bradford White						Rheem-Ruud					
Model	Kw	Gal.	Efficiency**	Dia.	Height	Model	Kw	Gal.	Efficiency**	Dia.	Height
Electric Tank-Type – Point-of-Use											
LE16U3-1	6 MAX	6	98%	14"	16-1/2"	EGSP6	6 max	6	98%	15-3/4"	15-1/8"
LE110U3-1	6 MAX	10	98%	16"	17-1/2"	EGSP10	6 max	10	98%	15-3/4"	22-7/8"
LE115U3-1	6 MAX	15	98%	18"	20-1/4"	EGSP15	6 max	15	98%	17-3/4"	24-1/4"
LE120U3-1	6 MAX	19	98%	18"	24-3/4"	EGSP20	6 max	19.9	98%	19-3/4"	25-1/8"
Electric Tank-Type – Light Duty											
LE130L3-3	12 max	30	98%	20"	30"	ELDS30	12 max	30	98%	22-1/4"	30"
LE140L3-3	12 max	40	98%	22"	31-1/4"	ELDS40	12 max	40	98%	23"	31-1/2"
LE150L3-3	12 max	50	98%	24"	31-3/4"	ELDS52	12 max	50	98%	26-1/4"	32"
LE230S3-3	12 max	30	98%	18"	46-1/2"	ELD30	12 max	30	98%	19-1/4"	47-1/2"
LE240S3-3	12 max	40	98%	20"	46-7/8"	ELD40	12 max	40	98%	20-1/4"	48-1/8"
LE250S3-3	12 max	50	98%	22"	46-1/2"	ELD52	12 max	50	98%	20-1/4"	58-1/2"
LE265T3-3	12 max	65	98%	22"	59-1/4"	ELD66	12 max	66	98%	22-1/4"	59-3/8"
LE280T3-3	12 max	80	98%	24"	59-1/4"	ELD80	12 max	80	98%	23-3/4"	59-1/2"
LE2120T3-3	12 max	119	98%	28"	62-1/4"	ELD120	12 max	119	98%	28-1/4"	62-7/8"
Electric Tank-Type – Heavy Duty											
M-II-50-xx-3SF/CF	54 max	50	98%	24"	47-3/4"	ES50/E50	54 max	50	98%	26-1/4"	43-5/8"
M-II-80-xx-3SF/CF	54 max	80	98%	26"	60-1/4"	ES85/E85	81 max	85	98%	28-1/4"	57-11/16"
M-II-120-xx-3SF/CF	54 max	119	98%	30-1/4"	64-1/2"	ES120/E120	81 max	119	98%	30-1/4"	67-5/8"
12A-x-3	9 max	12	98%	16"	28"	E12A	9 max	13	98%	19"	28-1/2"
20A-xx-3	18 max	20	98%	20"	27-1/2"	E20A	18 max	20	98%	19"	36-1/2"
30A-xx-3	36 max	30	98%	20"	38"	E30A	36 max	30	98%	19"	49-1/4"
40A-xx-3	36 max	40	98%	20"	48-1/4"	E40A	36 max	40	98%	21"	53-3/4"
50A-xx-3	81 max	50	98%	24"	47-3/4"	E50A	54 max	50	98%	26-1/4"	43-5/8"

**Accepted heat transfer efficiency of immersion heating elements.

Bradford White						Rheem-Ruud					
Model	Kw	Gal.	Efficiency**	Dia.	Height	Model	Kw	Gal.	Efficiency**	Dia.	Height
Electric Tank-Type – Heavy Duty Continued											
80A-xx-3	81 max	80	98%	26"	60-1/4"	E85A	81 max	85	98%	28-1/4"	57-11/16"
120A-xx-3	81 max	119	98%	30-1/4"	64-1/2"	E120A	81 max	119	98%	30-1/4"	67-5/8"
Electric Tank-Type – Dishwasher Booster											
L-I-6-xx-5CF	57 max	6	98%	n/a	n/a	E10	54 max	10	98%	21-3/4"	23"

Lochinvar						Rheem-Ruud					
Model	BTU/h	Gal.	Efficiency*	Dia.	Height	Model	BTU/h	Gal.	Efficiency*	Dia.	Height
Gas Tank Type – Atmospheric											
CGN065 065	65,000	65	n/a	24"	65"	G50-65	60,000	48	n/a	21-3/4"	61-3/4"
CGN075 075	75,000	75	n/a	26-1/2"	61"	G75-75N-2	75,100	75	80%	26-1/4"	64"
CGN075 100	75,000	100	n/a	27-3/4"	68-1/2"	G100-80	80,000	98	80%	28-1/4"	69-5/8"
Gas Tank Type – Atmospheric Dampened											
CGN120 070	120,000	71	80%	27-3/4"	69-3/4"	G75-125	125,000	75	80%	26-1/4"	65-1/2"
CGN150 080	154,000	81	80%	27-3/4"	73"	G82-156	156,000	82	80%	26-1/4"	68-13/16"
CGN180 080	180,000	81	80%	27-3/4"	67-1/2"	G76-180	180,000	76	80%	26-1/4"	68-13/16"
CGN200 032	199,000	32	80%	27-3/4"	45"	G37-200	199,900	35	80%	26-1/4"	49-1/4"
CGN200 080	199,000	81	80%	27-3/4"	67-1/2"	G91-200	199,900	91	80%	26-1/4"	76-5/8"
CGN200 100	199,000	100	80%	27-3/4"	75"	G91-200	199,900	91	80%	26-1/4"	76-5/8"
CGN199 100 (A)	199,000	100	80%	30-1/4"	72"	G100-200(A)	199,900	100	80%	30-1/4"	73-1/16"
CGN250 100 (A)	250,000	100	80%	30-1/4"	72"	G100-250(A)	250,000	100	80%	30-1/4"	73-1/4"
CGN250 065 (A)	251,000	65	80%	27-3/4"	75"	G72-250(A)	250,000	72	80%	26-1/4"	71-1/16"
CGN275 100 (A)	275,000	100	80%	30-1/4"	72"	G100-270(A)	270,000	100	80%	30-1/4"	73-7/8"

*Based on ANSI Z21.10.3 Thermal Efficiency Test.

Lochinvar						Rheem-Ruud					
Model	BTU/h	Gal.	Efficiency*	Dia.	Height	Model	BTU/h	Gal.	Efficiency*	Dia.	Height
Gas Tank Type – Atmospheric Dampened Continued											
CGN305 065 (A)	305,000	65	80%	27-3/4"	75"	G72-300(A)	300,000	72	80%	26-1/4"	71"
CGN365 085 (A)	365,000	85	80%	27-3/4"	79-1/2"	G65-360(A)	360,000	65	80%	26-1/4"	70-11/16"
CGN400 100 (A)	399,000	100	80%	30-1/4"	75-1/2"	G100-400(A)	399,900	100	80%	30-1/4"	76"
CGN500 100 (A)	500,000	85	80%	27-3/4"	82-1/4"	GX90-550(A)	550,000	90	80%	30"	74-1/2"
Gas Tank Type – Atmospheric, Low NOx Emission Compliant											
CXN120 070	120,000	71	82%	27-3/4"	63"	GN75-125	125,000	75	80%	26-1/4"	65-1/2"
CXN155 080	154,000	81	80%	27-3/4"	68"	GN82-156	156,000	82	80%	26-1/4"	68-13/16"
CXN180 100	180,000	100	80%	27-3/4"	72"	GN76-200	199,900	76	80%	26-1/4"	68-13/16"
CXN199 100 (A)	199,000	100	80%	27-3/4"	72"	GN91-200	199,900	91	80%	26-1/4"	76-5/16"
CXN250 100 (A)	250,000	100	80%	27-3/4"	72"	GN100-250(A)	250,000	100	80%	30-1/4"	73-1/4"
CXN275 100 (A)	275,000	100	80%	27-3/4"	72"	GN100-270(A)	270,000	100	80%	30-1/4"	73-7/8"
CXN365 085 (A)	366,000	85	80%	27-3/4"	73"	GN65-360(A)	360,000	65	80%	26-1/4"	70-11/16"
CXN400 085 (A)	390,000	85	80%	27-3/4"	73"	GN100-400(A)	399,900	100	80%	30-1/4"	76"
Gas Tank Type – Atmospheric, Ultra Low NOx Emission Compliant											
UTN100 75	75,100	98	80%	27-3/4"	70-1/2"	G100UN	75,100	98	80%	27-1/8"	67-7/8"
CLN120 080	120,000	81	82%	27-3/4"	68-1/4"	GNU75-125	125,000	75	80%	26-1/4"	65-1/2"
CLN155 080	154,000	81	82%	27-3/4"	68-1/4"	GNU82-156	156,000	82	80%	26-1/4"	68-13/16"
CLN180 100	180,000	93	82%	27-3/4"	76"	GNU76-200	199,900	76	80%	26-1/4"	68-13/16"
CLN199 100	199,000	93	82%	27-3/4"	76"	GNU91-200	199,900	91	82%	26-1/4"	76-5/16"
CLN250 100(A)	250,000	93	82%	27-3/4"	76"	GNU100-250(A)	250,000	100	80%	30-1/4"	73-1/4"
CLN275 085(A)	275,000	85	82%	27-3/4"	76"	GNU100-270(A)	270,000	100	82%	30-1/4"	73-7/8"
CLN366 085(A)	366,000	85	82%	27-3/4"	76"	GNU65-360(A)	360,000	65	80%	26-1/4"	70-11/16"
CLN400 085(A)	399,000	85	82%	27-3/4"	76"	GNU100-400(A)	399,900	100	80%	30-1/4"	76"

Lochinvar						Rheem-Ruud					
Model	BTU/h	Gal.	Efficiency*	Dia.	Height	Model	BTU/h	Gal.	Efficiency*	Dia.	Height
Gas Tank-Type – Power Direct Vented, Fully Condensing, Porcelain Coated Tank & External Heat Exchanger											
SNR125-065	125,000	65	96%	28"	60-1/4"	GHE80SS-130 GHE80SU-130	130,000	80	98%	26-3/8"	67-7/8"
SNR/SNA151-100	150,000	90	96%	28"	75-1/2"	GHE100SS-160(A) GHE100SU-160(A)	160,000	100	97%	26-3/8"	77"
SNR/SNA201-100	199,999	90	96%	28"	75-1/2"	GHE100SS-200(A) GHE100SU-200(A)	199,000	100	97%	26-3/8"	77"
SNA286-125	285,000	120	96%	34"	75-1/2"	GHE100SS-300(A) GHE100SU-300(A)	300,000	100	96%	26-3/8"	77"
SNA401-125	399,999	120	96%	34"	75-1/2"	GHE100SS-400(A) GHE100SU-400(A)	399,900	100	95%	26-3/8"	77"
SNA501-125	500,000	120	96%	34"	75-1/2"	GHE125-500A	500,000	125	93%	32"	78-1/2"

*Based on ANSI Z21.10.3 Thermal Efficiency Test.

Lochinvar						Rheem-Ruud					
Model	Kw	Gal.	Efficiency**	Dia.	Height	Model	Kw	Gal.	Efficiency**	Dia.	Height
Electric Tank-Type – Point-of-Use											
EJW006FS	2.5 max	6	98%	14-1/4"	15-1/2"	EGSP6	6 max	6	98%	15-3/4"	15-1/8"
EJW010FS	6 max	10	98%	18"	18-1/4"	EGSP10	6 max	10	98%	15-3/4"	22-7/8"
EJW015FS	6 max	15	98%	18"	26"	EGSP15	6 max	15	98%	24-1/4"	17-3/4"
EJW020FS	6 max	19	98%	21-3/4"	22-1/4"	EGSP20	6 max	19.9	98%	19-3/4"	25-1/8"

**Accepted heat transfer efficiency of immersion heating elements.

Lochinvar						Rheem-Ruud					
Model	Kw	Gal.	Efficiency**	Dia.	Height	Model	Kw	Gal.	Efficiency**	Dia.	Height
Electric Tank-Type – Light Duty											
ESX 030KD	12 max	30	98%	21-3/4"	31"	ELDS30	12 max	30	98%	22-1/4"	30"
ESX 040KD	12 max	40	98%	24"	32-1/4"	ELDS40	12 max	40	98%	23"	31-1/2"
ESX 050KD	12 max	50	98%	26-1/2"	32-1/4"	ELDS52	12 max	50	98%	26-1/4"	32"
ETX 030KD	12 max	30	98%	20-1/2"	34-1/2"	ELD30	12 max	30	98%	19-1/4"	47-1/2"
ETX 040KD	12 max	40	98%	20-1/2"	45-1/4"	ELD40	12 max	40	98%	20-1/4"	48-1/8"
ETX 050KD	12 max	50	98%	20-1/2"	55"	ELD52	12 max	50	98%	20-1/4"	58-1/2"
ETX 0650KD	12 max	66	98%	21-3/4"	60-3/4"	ELD66	12 max	66	98%	22-1/4"	59-3/8"
ETX 080KD	12 max	80	98%	24"	59-1/2"	ELD80	12 max	80	98%	23-3/4"	59-1/2"
ETX 120KD	12 max	119	98%	29-1/2"	62-1/2"	ELD120	12 max	119	98%	28-1/4"	62-7/8"
Electric Tank-Type – Heavy Duty											
HS/HC 050	54 max	50	98%	21-3/4"	55-3/4"	ES/E50	54 max	50	98%	26-1/4"	43-5/8"
HS/HC 080	54 max	80	98%	25-1/2"	60-1/4"	ES/E85	81 max	85	98%	28-1/4"	57-11/16"
HS/HC 119	54 max	119	98%	29-1/2"	62-1/4"	ES/E120	81 max	119	98%	30-1/4"	67-5/8"

**Accepted heat transfer efficiency of immersion heating elements.

State						Rheem-Ruud					
Model	BTU/h	Gal.	Efficiency*	Dia.	Height	Model	BTU/h	Gal.	Efficiency*	Dia.	Height
Gas Tank Type – Atmospheric											
SBS75 76NE	75,000	75	n/a	26-1/2"	61-1/8"	G75-75N-2	75,100	75	80%	26-1/4"	64"
SBS100 76NE	75,000	100	n/a	27-3/4"	68-5/8"	G100-80	80,000	98	80%	28-1/4"	69-5/8"
Gas Tank Type – Atmospheric Dampered											
SBD71 120NE	120,000	71	80%	27-3/4"	69-3/4"	G75-125	125,000	75	80%	26-1/4"	65-1/2"

State						Rheem-Ruud					
Model	BTU/h	Gal.	Efficiency*	Dia.	Height	Model	BTU/h	Gal.	Efficiency*	Dia.	Height
Gas Tank Type – Atmospheric Dampered Continued											
SBD81 154NE	154,000	81	80%	27-3/4"	73"	G82-156	156,000	82	80%	26-1/4"	68-13/16"
SBD81 180NE	180,000	81	80%	27-3/4"	67-1/2"	G76-180	180,000	76	80%	26-1/4"	68-13/16"
SBD100 199NET	199,000	100	80%	27-3/4"	75"	G91-200	199,900	91	80%	26-1/4"	76-5/8"
SBD100 199NE	199,000	100	80%	27-3/4"	75"	G91-200	199,900	91	80%	26-1/4"	76-5/8"
SBD81 199NE	190,000	81	80%	27-3/4"	67-1/2"	G76-200	199,900	76	80%	26-1/4"	68-13/16"
SBD100 199NES (A)	199,000	100	80%	30-1/4"	72"	G100-200(A)	199,900	100	80%	30-1/4"	73-1/16"
SBD100 250NE (A)	250,000	100	80%	30-1/4"	72"	G100-250(A)	250,000	100	80%	30-1/4"	73-1/4"
SBD65 251NE (A)	251,000	65	80%	27-3/4"	75"	G72-250(A)	250,000	72	80%	26-1/4"	71-1/16"
SBD100 275NE (A)	275,000	100	80%	30-1/4"	72"	G100-270(A)	270,000	100	80%	30-1/4"	73-7/8"
SBD65 305NE (A)	305,000	65	80%	27-3/4"	75"	G72-300(A)	300,000	72	80%	26-1/4"	71"
SBD85 365NE (A)	365,000	85	80%	27-3/4"	79-1/2"	G65-360(A)	360,000	65	80%	26-1/4"	70-11/16"
SBD100 390NE (A)	399,000	100	80%	30-1/4"	75-1/2"	G100-400(A)	399,900	100	80%	30-1/4"	76"
SBD85 500NE (A)	500,000	85	80%	27-3/4"	82-1/4"	GX90-550(A)	550,000	90	80%	30"	74-1/2"
Gas Tank Type – Atmospheric, Low NOx Emission Compliant											
SBS75 76NE	75,000	75	n/a	26-1/2"	61-1/8"	G75-75N-2	75,100	75	80%	26-1/4"	64"
SBS100 76NE	75,000	100	n/a	27-3/4"	68-5/8"	G100-80N	76,000	98	80%	28-1/4"	69-5/8"
SBN71 120NE	120,000	71	80%	27-3/4"	63"	GN75-125	125,000	75	80%	26-1/4"	65-1/2"
SBN81 154NE	154,000	81	80%	27-3/4"	68"	GN82-156	156,000	82	80%	26-1/4"	68-13/16"
SBN100 180NE	180,000	100	80%	27-3/4"	72"	GN76-200	199,900	76	80%	26-1/4"	68-13/16"
SBN95 199NE	199,000	93	82%	27-3/4"	72"	GN91-200	199,900	91	80%	26-1/4"	76-5/16"
SBN100 199NE	199,000	100	80%	27-3/4"	72"	GN91-200	199,900	91	80%	26-1/4"	76-5/16"

*Based on ANSI Z21.10.3 Thermal Efficiency Test.

State						Rheem-Ruud					
Model	BTU/h	Gal.	Efficiency*	Dia.	Height	Model	BTU/h	Gal.	Efficiency*	Dia.	Height
Gas Tank Type – Atmospheric, Low NOx Emission Compliant Continued											
SBN100 199NES (A)	199,000	100	80%	27-3/4"	72"	GN100-200(A)	199,900	100	80%	30-1/4"	73-1/16"
SBN100 200NES (A)	199,000	100	80%	30-1/4"	72"	GN100-200(A)	199,900	100	80%	30-1/4"	73-1/16"
SBN100 250NE (A)	250,000	100	80%	27-3/4"	72"	GN100-250(A)	250,000	100	80%	30-1/4"	73-1/4"
SBN100 275NE (A)	275,000	100	80%	27-3/4"	72"	GN100-270(A)	270,000	100	80%	30-1/4"	73-7/8"
SBN85 366NE (A)	366,000	85	80%	27-3/4"	73"	GN65-360(A)	360,000	65	80%	26-1/4"	70-11/16"
SBN85 390NE (A)	390,000	85	80%	27-3/4"	73"	GN100-400(A)	399,900	100	80%	30-1/4"	76"
Gas Tank Type – Atmospheric, Ultra Low NOx Emission Compliant											
SBB75 76NE	75,100	74	80%	25-1/4"	65-7/8"	G75UN	75,100	75	80%	26-1/4"	64-1/8"
SBL100 76NE	75,100	98	80%	27-3/4"	70-1/2"	G100UN	75,100	98	80%	27-1/8"	67-7/8"
SBL81 120NE	120,000	81	82%	27-3/4"	68-1/4"	GNU75-125	125,000	75	80%	26-1/4"	65-1/2"
SBL81 154NE	154,000	81	82%	27-3/4"	68-1/4"	GNU82-156	156,000	82	80%	26-1/4"	68-13/16"
SBL95 180NE	180,000	93	82%	27-3/4"	76"	GNU76-200	199,900	76	80%	26-1/4"	68-13/16"
SBL95 199NE	199,000	93	82%	27-3/4"	76"	GNU91-200	199,900	91	82%	26-1/4"	76-5/16"
SBL95 250NE(A)	250,000	93	82%	27-3/4"	76"	GNU100-250(A)	250,000	100	80%	30-1/4"	73-1/4"
SBL85 275NE(A)	275,000	85	82%	27-3/4"	76"	GNU100-270(A)	270,000	100	82%	30-1/4"	73-7/8"
SBL85 366NE(A)	366,000	85	82%	27-3/4"	76"	GNU65-360(A)	360,000	65	80%	26-1/4"	70-11/16"
SBL85 390NE(A)	399,000	85	82%	27-3/4"	76"	GNU100-400(A)	399,900	100	80%	30-1/4"	76"
Gas Tank-Type – Power Direct Vented (2 pipe)											
SDV75 70NE	70,000	75	n/a	26"	69-5/8"	GPDV75-75	75,100	75	80%	26-1/2"	70-3/8"
Gas Tank-Type – Power Direct Vented, Fully Condensing											
SHE50 100NE	100,000	50	95%	22"	66-3/4"	HE55-100	100,000	55	95%	23-1/2"	52"

State						Rheem-Ruud					
Model	BTU/h	Gal.	Efficiency*	Dia.	Height	Model	BTU/h	Gal.	Efficiency*	Dia.	Height
Gas Tank-Type – Power Direct Vented, Fully Condensing Continued											
SUF60 120 NEA	120,000	60	95%	27-3/4"	55-1/2"	GHE80SS-130(A) GHE80SU-130	130,000	80	98%	26-3/8"	67-7/8"
SUF100 150 NEA	150,000	100	95%	27-3/4"	75-1/2"	GHE100SS-160(A) GHE100SU-160(A)	160,000	100	97%	26-3/8"	77"
SUF100 199 NEA	199,000	100	95%	27-3/4"	75-1/2"	GHE100SS-200(A) GHE100SU-200(A)	199,000	100	97%	26-3/8"	77"
SUF100 250 NEA	250,000	100	95%	27-3/4"	75-1/2"	GHE100SS-250(A) GHE100SU-250(A)	250,000	100	98%	26-3/8"	77"
SUF130 300 NEA	300,000	130	96%	33-1/8"	75-1/2"	GHE100SS-300(A) GHE100SU-300(A)	300,000	100	96%	26-3/8"	77"
SUF130 400 NEA	399,900	130	95%	33-1/8"	75-1/2"	GHE100SU-400(A) GHE100SU-400(A)	399,900	100	95%	26-3/8"	77"
SUF130 500 NE	499,900	119	95%	33-1/8"	75-1/2"	GHE119-500	500,000	119	93%	32"	78-1/2"
SUF130 500 NEA	499,900	130	95%	33-1/8"	75-1/2"	GHE125-500A	500,000	125	93%	32"	78-1/2"

State						Rheem-Ruud					
Model	Kw	Gal.	Efficiency**	Dia.	Height	Model	Kw	Gal.	Efficiency**	Dia.	Height
Electric Tank-Type – Point-of-Use											
PCE 6 10MSA	2.5 max	6	98%	14-1/4"	15-1/2"	EGSP6	6 max	6	98%	15-3/4"	15-1/8"
PCE 10 10MSA	6 max	10	98%	18"	18-1/4"	EGSP10	6 max	10	98%	15-3/4"	22-7/8"
PCE 17 10MSA	6 max	15	98%	18"	26"	EGSP15	6 max	15	98%	17-3/4"	24-1/4"
PCE 20 10MSA	6 max	19.9	98%	21-3/4"	22-1/4"	EGSP20	6 max	19.9	98%	19-3/4"	25-1/8"

**Accepted heat transfer efficiency of immersion heating elements.

State						Rheem-Ruud					
Model	Kw	Gal.	Efficiency**	Dia.	Height	Model	Kw	Gal.	Efficiency**	Dia.	Height
Electric Tank-Type – Light Duty											
PCE 30 2OLSA	12 max	30	98%	21-3/4"	30-7/8"	ELDS30	12 max	30	98%	22-1/4"	30"
PCE 40 2OLSA	12 max	40	98%	24"	32-1/4"	ELDS40	12 max	40	98%	23"	31-1/2"
PCE 50 2OLSA	12 max	50	98%	26-1/2"	32-1/4"	ELDS52	12 max	50	98%	26-1/4"	32"
PCE 30 2ORTA	12 max	30	98%	20-1/2"	34-1/2"	ELD30	12 max	30	98%	19-1/4"	47-1/2"
PCE 40 2ORTA	12 max	40	98%	20-1/2"	45-1/8"	ELD40	12 max	40	98%	20-1/4"	48-1/8"
PCE 52 2ORTA	12 max	50	98%	20-1/2"	54-7/8"	ELD52	12 max	50	98%	20-1/4"	58-1/2"
PCE 66 2ORTA	12 max	66	98%	21-3/4"	60-3/4"	ELD66	12 max	66	98%	22-1/4"	59-3/8"
PCE 82 2ORTA	12 max	80	98%	24"	59-3/8"	ELD80	12 max	80	98%	23-3/4"	59-1/2"
PCE 120 2ORTA	12 max	119	98%	29-3/8"	62-7/16"	ELD120	12 max	119	98%	28-1/4"	62-7/8"
Electric Tank-Type – Heavy Duty											
CSB 52**SFE/IFE	54 max	50	98%	21-3/4"	55-3/4"	ES/E50	54 max	50	98%	26-1/4"	43-5/8"
CSB 82**SFE/IFE	54 max	80	98%	25-1/2"	60-1/4"	ES/E85	81 max	85	98%	28-1/4"	57-11/16"
CSB 120**SFE/IFE	54 max	119	98%	29-1/2"	62-1/4"	ES/E120	81 max	119	98%	30-1/4"	67-5/8"
SSE 10	6 max	10	98%	18-3/4"	26-1/4"	E12A	9 max	13	98%	19"	28-1/2"
SSE 20	18 max	20	98%	20-1/2"	27-1/4"	E20A	18 max	20	98%	19"	36-1/2"
SSE 30	24 max	30	98%	20-1/2"	35-3/4"	E30A	36 max	30	98%	19"	49-1/4"
SSE 40	36 max	40	98%	20-1/2"	45-3/4"	E40A	36 max	40	98%	21"	53-3/4"
SSE 50	90 max	50	98%	20-1/2"	54-3/4"	E50A	54 max	50	98%	26-1/4"	43-5/8"
SSE 65	90 max	65	98%	26-1/2"	50-1/2"	E85A	81 max	85	98%	28-1/4"	57-11/16"
SSE 80	90 max	80	98%	28"	49-1/4"	E85A	81 max	85	98%	28-1/4"	57-11/16"
SSE 100	90 max	100	98%	28"	58-1/4"	E120A	81 max	119	98%	30-1/4"	67-5/8"
SSE 120	90 max	119	98%	30"	63-1/4"	E120A	81 max	119	98%	30-1/4"	67-5/8"

**Accepted heat transfer efficiency of immersion heating elements.

Customer Service, Warranty & Parts 1.800.621.5622

Fax 1.800.535.9538

Technical Service 1.800.432.8373 (1.800.HEATER3)

Technical Service for Hybrid Water Heaters 1.800.995.0982

EcoNet Support 1.800.255.2388

Tankless Gas Support 1.866.720.2076

Tankless Electric Support 1.800.374.8806

Plumbing Support 1.866.339.2388

Email sales@rheem.com

Rheem Water Heating

1115 Northmeadow Parkway, Suite 100

Roswell, Georgia 30076 | Rheem.com

Rheem manufactures residential and commercial heating and cooling and water heating products.

In keeping with its policy of continuous progress and product improvement, Rheem reserves the right to make changes without notice.



The new degree of comfort.®



PRINTED IN U.S.A. 02/19 WP
FORM NO. RH-PG Rev. 14



INTEGRATED HOME COMFORT