

INSTALLATION INSTRUCTIONS

15 SEER SERIES HEAT PUMPS 1½ - 5 TONS FEATURING EARTH-FRIENDLY R-410A REFRIGERANT [®]R-410A



RECOGNIZE THIS SYMBOL AS AN INDICATION OF IMPORTANT SAFETY INFORMATION!

▲ WARNING

THESE INSTRUCTIONS ARE INTENDED AS AN AID TO QUALIFIED, LICENSED SERVICE PERSONNEL FOR PROPER INSTALLATION, ADJUSTMENT AND OPERATION OF THIS UNIT. READ THESE INSTRUCTIONS THOROUGHLY BEFORE ATTEMPTING INSTALLATION OR OPERATION. FAILURE TO FOLLOW THESE INSTRUCTIONS MAY RESULT IN IMPROPER INSTALLATION, ADJUSTMENT, SERVICE OR MAINTENANCE POSSIBLY RESULTING IN FIRE, ELECTRICAL SHOCK, PROPERTY DAMAGE, PERSONAL INJURY OR DEATH.



ISO 9001:2008
Certificate Number: 30164

DO NOT DESTROY THIS MANUAL
PLEASE READ CAREFULLY AND KEEP IN A SAFE PLACE FOR FUTURE REFERENCE BY A SERVICEMAN



TABLE OF CONTENTS

1.0 SAFETY INFORMATION	3
2.0 GENERAL INFORMATION	4
2.1 Checking Product Received	4
2.2 Applications	4
2.3 Dimensions	5
2.4 Electrical and Physical Data	6
3.0 LOCATING UNIT	6
3.1 Corrosive Environment	6
3.2 Heat Pump Location	7
3.3 Operational Issues	7
3.4 For Units With Space Limitations	7
3.5 Customer Satisfaction Issues	8
3.6 Unit Mounting	8
3.7 Factory-Preferred Tie-Down Method	8
4.0 REFRIGERANT CONNECTIONS	9
5.0 REPLACEMENT UNITS	9
6.0 INDOOR COIL	9
6.1 Location	9
7.0 INTERCONNECTING TUBING	10
7.1 Vapor & Liquid Lines	10
7.2 Maximum Length of Lines	10
7.3 Vertical Separation	10
7.4 Tubing Installation	10
7.5 Tubing Connections	11
7.6 Leak Testing	11
8.0 DEMAND DEFROST CONTROL	15
8.1 Defrost Initiation	15
8.2 Defrost Termination	15
8.3 Temperature Sensors	15
8.4 Test Mode	15
8.5 Trouble Shooting Demand Defrost Operation	15
8.6 High/Low Pressure Control Monitoring	16
8.7 Enhanced Feature Defrost Control Diagnostic Codes	16
9.0 CHECKING AIRFLOW	16
10.0 EVACUATION AND LEAK TESTING	17
10.1 Evacuation Procedure	17
10.2 Final Leak Testing	17
11.0 CHECKING REFRIGERANT CHARGE	18
11.1 Charging Units With R-410A Refrigerant	18
11.2 Measurement Device Setup	19
11.3 Charging By Weight	19
11.4 Gross Charging By Pressures	19
11.5 Final Charge By Sub-Cooling	20
11.6 Finishing Up Installation	21
12.0 ELECTRICAL WIRING	21
12.1 Power Wiring	22
12.2 Grounding	22
12.3 Control Wiring	22
13.0 FIELD INSTALLED ACCESSORIES	23
13.1 Compressor Crankcase Heat	23
13.2 Low Ambient Control	23
13.3 High Pressure Control	24
13.4 Heat Pump Thermostat Warning Light Kit RXPX-D01	24
14.0 SERVICE	24
14.1 Single Pole Compressor Contactor	24
15.0 TROUBLESHOOTING	25
15.1 Electrical Checks Flow Chart	25
15.2 Cooling Mechanical Checks Flow Chart	26
15.3 Heating Mechanical Checks Flow Chart	27
15.4 Defrost Mechanical Checks Flow Chart	28
15.5 General Troubleshooting Chart	30
15.6 Service Analyzer Chart	31-35
16.0 WIRING DIAGRAMS	37
16.1 Enhanced Defrost Control - PSC Motor	37
16.2 Enhanced Defrost Control - ECM Motor	38

1.0 SAFETY INFORMATION

WARNING

Disconnect all power to unit before starting maintenance. Failure to do so can cause electrical shock resulting in severe personal injury or death.

WARNING

Turn off electric power at the fuse box or service panel before making any electrical connections.

Also, the ground connection must be completed before making line voltage connections. Failure to do so can result in electrical shock, severe personal injury or death.

WARNING

These instructions are intended as an aid to qualified licensed service personnel for proper installation, adjustment and operation of this unit. Read these instructions thoroughly before attempting installation or operation. Failure to follow these instructions may result in improper installation, adjustment, service or maintenance possibly resulting in fire, electrical shock, property damage, personal injury or death.

WARNING

The unit must be permanently grounded. Failure to do so can cause electrical shock resulting in severe personal injury or death.

WARNING

The manufacturer's warranty does not cover any damage or defect to the heat pump caused by the attachment or use of any components. Accessories or devices (other than those authorized by the manufacturer) into, onto or in conjunction with the heat pump. You should be aware that the use of unauthorized components, accessories or devices may adversely affect the operation of the heat pump and may also endanger life and property. The manufacturer disclaims any responsibility for such loss or injury resulting from the use of such unauthorized components, accessories or devices.

CAUTION

When coil is installed over a finished ceiling and/or living area, it is recommended that a secondary sheet metal condensate pan be constructed and installed under entire unit. Failure to do so can result in property damage.

CAUTION

Single-pole contactors are used on all standard single-phase units up through 5 tons. Caution must be exercised when servicing as only one leg of the power supply is broken with the contactor.

2.0 GENERAL

WARNING

The manufacturer's warranty does not cover any damage or defect to the heat pump caused by the attachment or use of any components. Accessories or devices (other than those authorized by the manufacturer) into, onto or in conjunction with the heat pump. You should be aware that the use of unauthorized components, accessories or devices may adversely affect the operation of the heat pump and may also endanger life and property. The manufacturer disclaims any responsibility for such loss or injury resulting from the use of such unauthorized components, accessories or devices.

2.1 CHECKING PRODUCT RECEIVED

Upon receiving unit, inspect it for any shipping damage. Claims for damage, either apparent or concealed, should be filed immediately with the shipping company. Check heat pump model number, electrical characteristics and accessories to determine if they are correct. Check system components (evaporator coil, condensing unit, evaporator blower, etc.) to make sure they are properly matched. The information contained in this manual has been prepared to assist in the proper installation, operation and maintenance of the heat pump system. Improper installation, or installation not made in accordance with these instructions, can result in unsatisfactory operation and/or dangerous conditions, and can cause the related warranty not to apply.

Read this manual and any instructions packaged with separate equipment required to make up the system prior to installation. Retain this manual for future reference.

To achieve optimum efficiency and capacity, the indoor cooling coils listed in the heat pump specification sheet should be used.

2.2 APPLICATION

Before installing any heat pump equipment, a duct analysis of the structure and a heat gain calculation must be made. A heat gain calculation begins by measuring all external surfaces and openings that gain heat from the surrounding air and quantifying that heat gain. A heat gain calculation also calculates the extra heat load caused by sunlight and by humidity removal.

There are several factors that the installers must consider:

- Outdoor unit location
- System refrigerant charge
- Indoor unit blower speed
- System air balancing
- Proper equipment evacuation
- Indoor unit airflow
- Supply and return air duct design and sizing
- Diffuser and return air grille location and sizing

MATCH ALL COMPONENTS:

- OUTDOOR UNIT
- INDOOR COIL/METERING DEVICE
- INDOOR AIR HANDLER/FURNACE
- REFRIGERANT LINES

2.3 DIMENSIONS (SEE FIGURE 1)

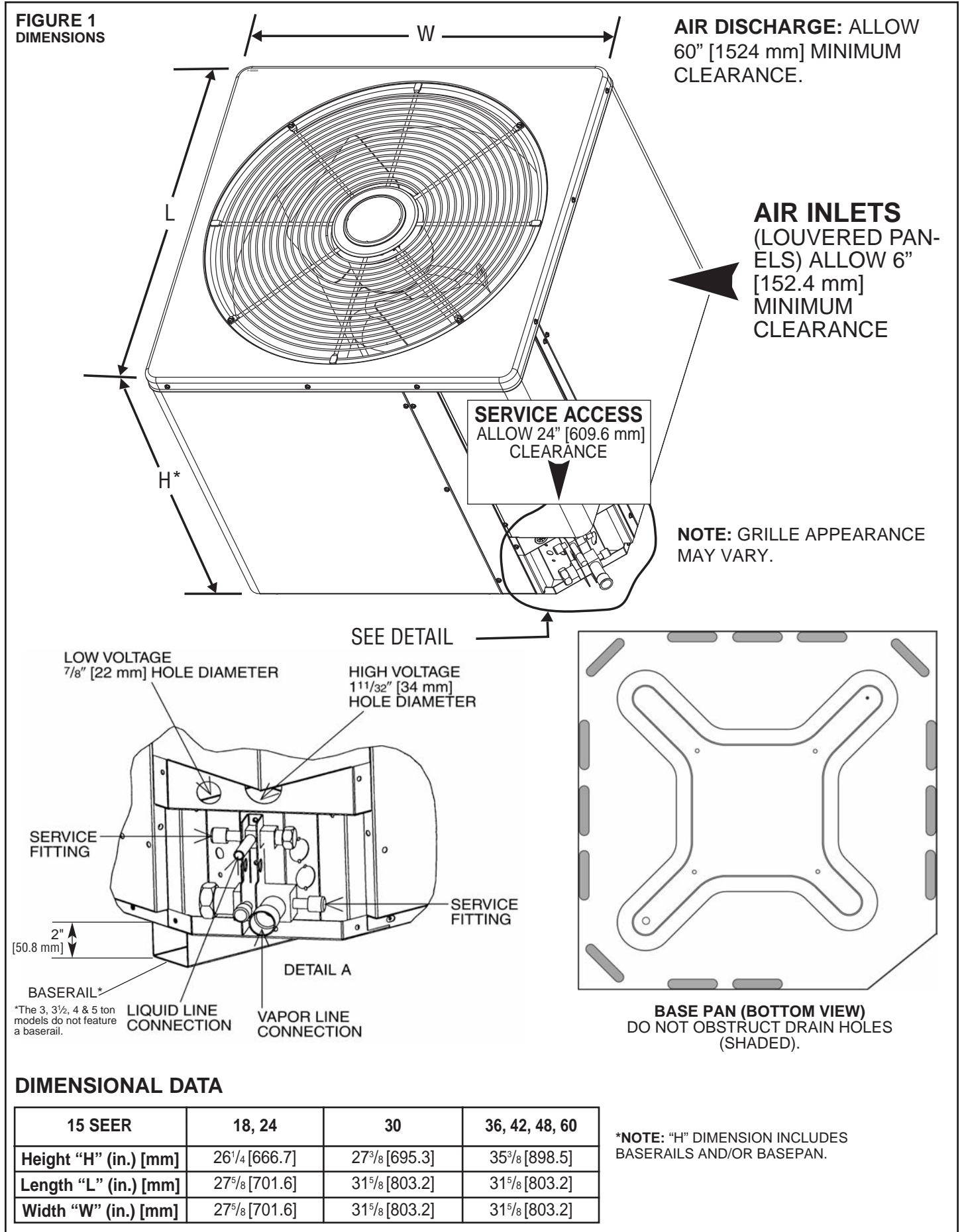

2.4 ELECTRICAL & PHYSICAL DATA (SEE TABLE 1)

TABLE 1
ELECTRICAL AND PHYSICAL DATA – 15 SEER

Model Number	ELECTRICAL DATA							PHYSICAL DATA					
	Phase Frequency (Hz) Voltage (Volts)	Compressor		Fan Motor Full Load Amperes (FLA)	Minimum Circuit Ampacity Amperes	Fuse or HACR Circuit Breaker		Outdoor Coil			Refrig. Per Circuit Oz. [g]	Weight	
		Rated Load Amperes (RLA)	Locked Rotor Amperes (LRA)			Minimum Amperes	Maximum Amperes	Face Area Sq. Ft. [m ²]	No. Rows	CFM [L/s]		Net Lbs. [kg]	Shipping Lbs. [kg]
Rev. 2/3/2010													
18	1-60-208/230	9/9	48	0.8	13/13	15/15	20/20	13.72 [1.27]	1	2590 [1222]	95.6 [2710]	154 [69.9]	164 [74.4]
24	1-60-208/230	13.5/13.5	58.3	0.8	18/18	25/25	30/30	13.72 [1.27]	1	2590 [1222]	94.2 [2671]	155 [70.3]	165 [74.8]
30	1-60-208/230	12.8/12.8	64	1	18/18	25/25	25/25	16.39 [1.52]	1	2595 [1225]	114.5 [3246]	169 [76.7]	181 [82.1]
36	1-60-208/230	16.7/16.7	79	1.4	23/23	30/30	35/35	21.85 [2.03]	1	3000 [1416]	138 [3912]	193 [87.5]	207 [93.9]
42	1-60-208/230	17.9/17.9	112	1.9	25/25	30/30	40/40	21.85 [2.03]	1	3575 [1687]	146.5 [4153]	210 [95.3]	224 [101.6]
48	1-60-208/230	19.9/19.9	109	1	26/26	35/35	45/45	21.85 [2.03]	1	3575 [1687]	229.2 [6498]	210 [95.3]	224 [101.6]
60	1-60-208/230	21.4/21.4	135	2.8	30/30	35/35	50/50	21.85 [2.03]	2	3925 [1852]	279 [7910]	264 [119.8]	278 [126.1]

NOTES:

- ① 20 Fins per inch [mm]
- ② Factory charged for 15 ft. [4.6 m] of line set

3.0 LOCATING UNIT

3.1 CORROSIVE ENVIRONMENT

The metal parts of this unit may be subject to rust or deterioration if exposed to a corrosive environment. This oxidation could shorten the equipment's useful life. Corrosive elements include, but are not limited to, salt spray, fog or mist in seacoast areas, sulphur or chlorine from lawn watering systems, and various chemical contaminants from industries such as paper mills and petroleum refineries.

If the unit is to be installed in an area where contaminants are likely to be a problem, special attention should be given to the equipment location and exposure.

- Avoid having lawn sprinkler heads spray directly on the unit cabinet.
- In coastal areas, locate the unit on the side of the building away from the waterfront.
- Shielding provided by a fence or shrubs may give some protection, but cannot violate minimum airflow and service access clearances.
- Elevating the unit off its slab or base enough to allow air circulation will help avoid holding water against the basepan.

Regular maintenance will reduce the build-up of contaminants and help to protect the unit's finish.

WARNING

Disconnect all power to unit before starting maintenance. Failure to do so can cause electrical shock resulting in severe personal injury or death.

- Frequent washing of the cabinet, fan blade and coil with fresh water will remove most of the salt or other contaminants that build up on the unit.
- Regular cleaning and waxing of the cabinet with an automobile polish will provide some protection.
- A liquid cleaner may be used several times a year to remove matter that will not wash off with water.

Several different types of protective coil coatings are offered in some areas. These coatings may provide some benefit, but the effectiveness of such coating materials cannot be verified by the equipment manufacturer.

3.2 HEAT PUMP LOCATION

Consult local and national building codes and ordinances for special installation requirements. Following location information will provide longer life and simplified servicing of the outdoor heat pump.

NOTE: These units must be installed outdoors. No ductwork can be attached, or other modifications made, to the discharge grille. Modifications will affect performance or operation.

3.3 OPERATIONAL ISSUES

- **IMPORTANT:** Locate the unit in a manner that will not prevent, impair or compromise the performance of other equipment horizontally installed in proximity to the unit. Maintain all required minimum distances to gas and electric meters, dryer vents, exhaust and inlet openings. In the absence of National Codes, or manufacturers' recommendations, local code recommendations and requirements will take precedence.
- Refrigerant piping and wiring should be properly sized and kept as short as possible to avoid capacity losses and increased operating costs.
- Locate the unit where water run off will not create a problem with the equipment. Position the unit away from the drip edge of the roof whenever possible. Units are weatherized, but can be affected by the following:
 - o Water pouring into the unit from the junction of rooflines, without protective guttering. Large volumes of water entering the heat pump while in operation can impact fan blade or motor life, and coil damage may occur to a heat pump if moisture cannot drain from the unit under freezing conditions.
 - o Freezing moisture, or sleeting conditions, can cause the cabinet to ice-over prematurely and prevent heat pump operation, requiring backup heat, which generally results in less economical operation.
- Closely follow clearance recommendations (See Figure 1).
 - o 24" [609.6 mm] to the service panel access
 - o 60" [1524 mm] above heat pump fan discharge (unit top) to prevent recirculation
 - o 6" [152.4 mm] to heat pump coil grille air inlets (per heat pump).

IMPORTANT: Remove attached shipping strap. Failure to remove strap could result in internal tubing stress. Plastic strap can be cut off from the exterior of the unit and left inside of the unit. See page 31.

3.4 FOR UNITS WITH SPACE LIMITATIONS

In the event that a space limitation exists, we will permit the following clearances:

Single Unit Applications: Clearances below 6 inches [152.4 mm] will reduce unit capacity and efficiency. Do not reduce the 60-inch [1524 mm] discharge, or the 24-inch [609.6 mm] service clearances.

Multiple Unit Applications: When multiple heat pump grille sides are aligned, a 6-inch [152.4 mm] per unit clearance is recommended, for a total of 12" [304.8 mm] between two units. Two combined clearances below 12 inches [304.8 mm] will reduce capacity and efficiency. Do not reduce the 60-inch [1524 mm] discharge, or 24-inch [609.6 mm] service, clearances.

FIGURE 2
RECOMMENDED ELEVATED INSTALLATION

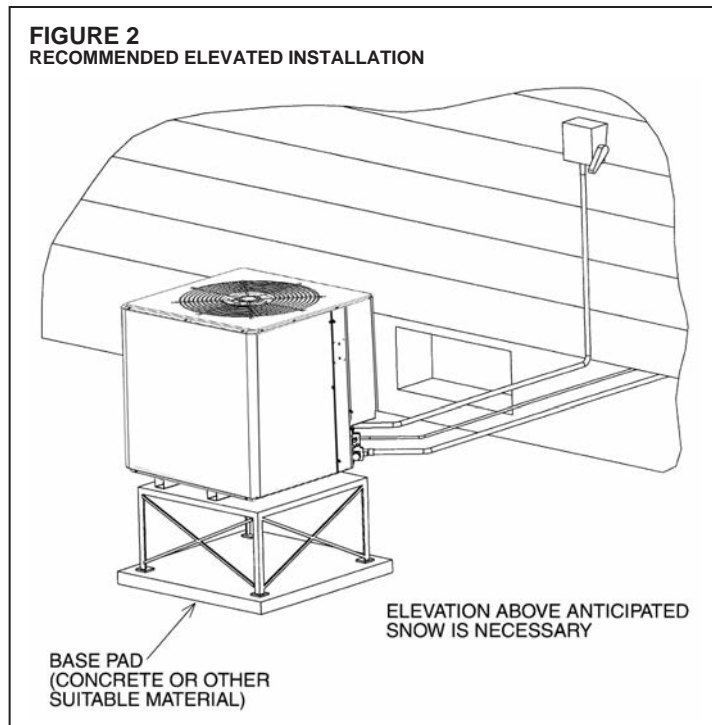

- Do not obstruct the bottom drain opening in the heat pump base pan. It is essential to provide defrost condensate drainage to prevent possible refreezing of the condensation. Provide a base pad for mounting the unit, which is slightly pitched away from the structure. Route condensate off the base pad to an area which will not become slippery and result in personal injury.
- Where snowfall is anticipated, the heat pump must be elevated above the base pad to prevent ice buildup that may crush the tubing of the heat pump coil or cause fin damage. Heat pump units should be mounted above the average expected accumulated snowfall for the area.

3.5 CUSTOMER SATISFACTION ISSUES

- The heat pump should be located away from the living, sleeping and recreational spaces of the owner and those spaces on adjoining property.
- To prevent noise transmission, the mounting pad for the outdoor unit should not be connected to the structure, and should be located sufficient distance above grade to prevent ground water from entering the unit.

3.6 UNIT MOUNTING

If elevating the heat pump, either on a flat roof or on a slab, observe the following guidelines.

- The base pan provided elevates the heat pump 2" [50.8 mm] above the base pad.
- If elevating a unit on a flat roof, use 4" x 4" [101.6 mm x 101.6 mm] (or equivalent) stringers positioned to distribute unit weight evenly and prevent noise and vibration (see Figure 2).

NOTE: Do not block drain openings shown in Figure 1.

- If unit must be elevated because of anticipated snow fall, secure unit and elevating stand such that unit and/or stand will not tip over or fall off. Keep in mind that someone may try to climb on unit.

3.7 FACTORY-PREFERRED TIE-DOWN METHOD FOR OUTDOOR UNITS

IMPORTANT: The Manufacturer's approved/recommended method is a guide to securing equipment for wind and seismic loads. Other methods might provide the same result, but the Manufacturer's method is the only one endorsed by the Manufacturer for securing equipment where wind or earthquake damage can occur. Additional information is available in the PTS (Product Technical Support) section of the Manufacturer's website Rheemote.net and can be found as a listing under each outdoor model. If you do not have access to this site, your Distributor can offer assistance.

4.0 REFRIGERANT CONNECTIONS

All units are factory charged with Refrigerant 410A for 15 ft. [4.6 m] of line set. All models are supplied with service valves. Keep tube ends sealed until connection is to be made to prevent system contamination.

5.0 REPLACEMENT UNITS

To prevent failure of a new heat pump unit, the existing tubing system must be correctly sized and cleaned or replaced. Care must be exercised that the expansion device is not plugged. For new and replacement units, a liquid line filter drier should be installed and refrigerant tubing should be properly sized. Test the oil for acid. If positive, a liquid line filter drier is mandatory.

6.0 INDOOR COIL

REFER TO INDOOR COIL MANUFACTURER'S INSTALLATION INSTRUCTIONS.

IMPORTANT: The manufacturer is not responsible for the performance and operation of a mismatched system, or for a match listed with another manufacturer's coil.

6.1 LOCATION

Do not install the indoor coil in the return duct system of a gas or oil furnace. Provide a service inlet to the coil for inspection and cleaning. Keep the coil pitched toward the drain connection.

CAUTION

When coil is installed over a finished ceiling and/or living area, it is recommended that a secondary sheet metal condensate pan be constructed and installed under entire unit. Failure to do so can result in property damage.

7.0 INTERCONNECTING TUBING

7.1 VAPOR AND LIQUID LINES

Keep all lines sealed until connection is made.

Make connections at the indoor coil first.

Refer to Line Size Information in Tables 2 and 3 for correct size and multipliers to be used to determine capacity for various vapor line diameters and lengths of run. The losses due to the lines being exposed to outdoor conditions are not included.

The factory refrigeration charge in the outdoor unit is sufficient for 15 feet [4.6 m] of interconnecting lines. The factory refrigeration charge in the outdoor unit is sufficient for the unit and 15 feet [4.6 m] of standard size interconnecting liquid and vapor lines. For different lengths, adjust the charge as indicated below.

1/4" ± .3 oz. per foot [6.35 mm ± 8.5 g]

5/16" ± .4 oz. per foot [7.9 mm ± 11.3 g]

3/8" ± .6 oz. per foot [9.5 mm ± 17 g]

1/2" ± 1.2 oz. per foot [12.7 mm ± 34 g]

7.2 MAXIMUM LENGTH OF LINES

The maximum length of interconnecting line is 150 feet [45.7 m]. Always use the shortest length possible with a minimum number of bends. Additional compressor oil is not required for any length up to 150 feet [45.7 m].

NOTE: Excessively long refrigerant lines cause loss of equipment capacity.

7.3 VERTICAL SEPARATION

Keep the vertical separation to a minimum. Use the following guidelines when installing the unit:

1. DO NOT exceed the vertical separations as indicated on Table 3.
2. It is recommended to use the smallest liquid line size permitted to minimize system charge which will maximize compressor reliability.
3. Table 3 may be used for sizing horizontal runs.

7.4 TUBING INSTALLATION

Observe the following when installing correctly sized type "L" refrigerant tubing between the condensing unit and evaporator coil:

- If a portion of the liquid line passes through a hot area where liquid refrigerant can be heated to form vapor, insulating the liquid line is required.
- Use clean, dehydrated, sealed refrigeration grade tubing.
- Always keep tubing sealed until tubing is in place and connections are to be made.
- Blow out the liquid and vapor lines with dry nitrogen before connecting to the outdoor unit and indoor coil. Any debris in the line set will end up plugging the expansion device.
- As an added precaution it is recommended that a high quality, bi-directional filter drier is installed in the liquid line.
- Do not allow the vapor line and liquid line to be in contact with each other. This causes an undesirable heat transfer resulting in capacity loss and increased power consumption. The vapor line must be insulated.
- If tubing has been cut, make sure ends are deburred while holding in a position to prevent chips from falling into tubing. Burrs such as those caused by tubing cutters can affect performance dramatically, particularly on small liquid line sizes.
- For best operation, keep tubing run as short as possible with a minimum number of elbows or bends.
- Locations where the tubing will be exposed to mechanical damage should be avoided. If it is necessary to use such locations, the copper tubing should be housed to prevent damage.

- If tubing is to be run underground, it must be run in a sealed watertight chase.
- Use care in routing tubing and do not kink or twist. Use a tubing bender on the vapor line to prevent kinking.
- Route the tubing using temporary hangers, then straighten the tubing and install permanent hangers. Line must be adequately supported.
- The vapor line must be insulated to prevent dripping (sweating) and prevent performance losses. Armaflex and Rubatex are satisfactory insulations for this purpose. Use 1/2" [12.7 mm] minimum insulation thickness, additional insulation may be required for long runs.
- Check Table 2 for the correct vapor line size. Check Table 3 for the correct liquid line size.

7.5 TUBING CONNECTIONS

Indoor coils have only a holding charge of dry nitrogen. Keep all tube ends sealed until connections are to be made.

- Use type "L" copper refrigeration tubing. Braze the connections with accepted industry practices.
- Be certain both refrigerant shutoff valves at the outdoor unit are closed.
- Clean the inside of the fittings before brazing.
- Remove the cap and schrader core from service port to protect seals from heat damage.
- Use an appropriate heatsink material around the copper stub and the service valves before applying heat.
- **IMPORTANT:** Do not braze any fitting with the TEV sensing bulb attached.
- Braze the tubing between the outdoor unit and indoor coil. Flow dry nitrogen into a service port and through the tubing while brazing.
- The service valves are not backseating valves. To open the valves, remove the valve cap with an adjustable wrench. Insert a 3/16" [4.7 mm] or 5/16" [7.9 mm] hex wrench into the stem. Back out counterclockwise.
- Replace the valve cap finger tight then tighten an additional 1/2 hex flat for a metal-to-metal seal.

7.6 LEAK TESTING

- Pressurize line set and coil through service fittings with dry nitrogen to 150 PSIG [1034.2 kPa] maximum. Leak test all joints using liquid detergent. If a leak is found, relieve pressure and repair.

TABLE 2
SUCTION LINE LENGTH/SIZE VS CAPACITY MULTIPLIER (R-410A)

Unit Size		1 1/2 Ton	2 Ton	2 1/2 Ton	3 Ton	3 1/2 Ton	4 Ton	5 Ton
Suction Line Connection Size		3/4" [19] I.D.	3/4" [19] I.D.	3/4" [19] I.D.	3/4" [19] I.D.	7/8" [22.2] I.D.	7/8" [22.2] I.D.	7/8" [22.2] I.D.
Suction Line Run - Feet [m]		5/8 [15.9] Opt. 3/4* [19] Std. —	5/8 [15.9] Opt. 3/4* [19] Std. —	5/8 [15.9] Opt. 3/4* [19] Std. 7/8 [22.2] Opt.	5/8 [15.9] Opt. 3/4* [19] Std. 7/8 [22.2] Opt.	3/4 [19] Opt. 7/8* [22.2] Opt. —	7/8 [22.2]* Std. 1 1/8 Opt. —	7/8 [22.2]* Std. 1 1/8 [28.6] Opt. —
25' [7.6] —	Optional	1.00	1.00	1.00	1.00	1.00	1.00	1.00
	Standard	1.00	1.00	1.00	1.00	1.00	1.00	1.00
	Optional	—	—	1.00	—	—	—	—
50' [15.24] —	Optional	0.98	0.98	0.96	0.98	0.99	0.99	0.99
	Standard	0.99	0.99	0.98	0.99	0.99	0.99	0.99
	Optional	—	—	0.99	—	—	—	—
100' [30.5] —	Optional	0.95	0.95	0.94	0.96	0.96	0.96	0.97
	Standard	0.96	0.96	0.96	0.97	0.98	0.98	0.98
	Optional	—	—	0.97	—	—	—	—
150' [45.7] —	Optional	0.92	0.92	0.91	0.94	0.94	0.95	0.94
	Standard	0.93	0.94	0.93	0.95	0.96	0.96	0.97
	Optional	—	—	0.95	—	—	—	—

NOTES:

*Standard line size

Using suction line larger than shown in chart will result in poor oil return and is not recommended.

TABLE 3
LIQUID LINE SIZING (R-410A)

R-410A System Capacity Model	Line Size Connection Size (Inch I.D.) [mm]	Line Size (Inch O.D.) [mm]	Liquid Line Size					
			Outdoor unit Above or Below Indoor Coil (Heat Pump Only)					
			Total Equivalent Length - Feet [m]					
			25 [7.62]	50 [15.24]	75 [22.86]	100 [30.48]	125 [45.72]	150 [45.72]
			Maximum Vertical Separation - Feet [m]					
1 1/2 Ton	3/8" [9.53]	1/4" [6.35]	25 [7.62]	16 [4.88]	N/A	N/A	N/A	N/A
		5/16" [7.93]	25 [7.62]	40 [12.19]	36 [10.97]	32 [9.75]	28 [8.53]	23 [7.01]
		3/8" [9.52]*	25 [7.62]	45 [13.72]	44 [13.41]	42 [12.80]	41 [12.50]	39 [11.89]
2 Ton	3/8" [9.53]	1/4" [6.35]	25 [7.62]	22 [6.71]	N/A	N/A	N/A	N/A
		5/16" [7.93]	25 [7.62]	50 [15.24]	52 [15.85]	46 [14.02]	40 [12.19]	33 [10.06]
		3/8" [9.52]*	25 [7.62]	50 [15.24]	64 [19.51]	62 [18.90]	60 [18.29]	58 [17.68]
2 1/2 Ton	3/8" [9.53]	1/4" [6.35]	14 [4.27]	N/A	N/A	N/A	N/A	N/A
		5/16" [7.93]	25 [7.62]	32 [9.75]	23 [7.01]	14 [4.27]	N/A	N/A
		3/8" [9.52]*	25 [7.62]	44 [13.41]	41 [12.50]	38 [11.58]	35 [10.67]	32 [9.75]
3 Ton	3/8" [9.53]	5/16" [7.93]	25 [7.62]	50 [15.24]	43 [13.11]	30 [9.14]	16 [4.88]	N/A
		3/8" [9.52]*	25 [7.62]	50 [15.24]	69 [21.03]	65 [19.81]	60 [18.29]	55 [16.76]
		1/2" [12.70]	25 [7.62]	50 [15.24]	75 [22.86]	79 [24.08]	78 [23.77]	78 [23.77]
3 1/2 Ton	3/8" [9.53]	5/16" [7.93]	25 [7.62]	37 [11.28]	19 [5.79]	N/A	N/A	N/A
		3/8" [9.52]*	25 [7.62]	50 [15.24]	53 [16.15]	47 [14.33]	41 [12.50]	36 [10.97]
		1/2" [12.70]	25 [7.62]	50 [15.24]	68 [20.73]	66 [20.12]	65 [19.81]	64 [19.51]
4 Ton	3/8" [9.53]	5/16" [7.93]	22 [6.71]	N/A	N/A	N/A	N/A	N/A
		3/8" [9.52]*	25 [7.62]	30 [9.14]	22 [6.71]	13 [3.96]	N/A	N/A
		1/2" [12.70]	25 [7.62]	44 [13.41]	43 [13.11]	41 [12.50]	39 [11.89]	37 [11.28]
5 Ton	3/8" [9.53]	3/8" [9.52]*	25 [7.62]	33 [10.06]	24 [7.32]	14 [4.27]	N/A	N/A
		1/2" [12.70]	25 [7.62]	49 [14.94]	47 [14.33]	45 [13.72]	43 [13.11]	41 [12.50]

NOTES:

*Standard line size
N/A - Application not recommended.

TABLE 4
SUCTION LINE SIZING (R-410A)

SUCTION LINE SIZE - OUTDOOR UNIT ABOVE INDOOR COIL							
R-410A System Capacity Model	Line Size Connection Size (Inch I.D.) [mm]	Line Size (Inch O.D.) [mm]	Suction Line Size				
			Outdoor Unit ABOVE Indoor Coil (Heat Pumps)				
			Total Equivalent Length - Feet [m]				
			25 [7.62]	50 [15.24]	75 [22.86]	100 [30.48]	125 [45.72]
1 1/2 Ton	3/4" [19.05]	5/8" [15.88]	Same as Liquid Line Size Table				
		3/4" [19.05]*	NA				
		7/8" [22.23]	NA				
2 Ton	3/4" [19.05]	5/8" [15.88]	Same as Liquid Line Size Table				
		3/4" [19.05]*	NA				
		7/8" [22.23]	NA				
2 1/2 Ton	3/4" [19.05]	5/8" [15.88]	Same as Liquid Line Size Table				
		3/4" [19.05]*	Same as Liquid Line Size Table				
		7/8" [22.23]	NA				
3 Ton	3/4" [19.05]	5/8" [15.88]	Same as Liquid Line Size Table				
		3/4" [19.05]*	Same as Liquid Line Size Table				
		7/8" [22.23]	Same as Liquid Line Size Table				
3 1/2 Ton	7/8" [22.23]	5/8" [15.88]	Same as Liquid Line Size Table				
		3/4" [19.05]	Same as Liquid Line Size Table				
		7/8" [22.23]*	Same as Liquid Line Size Table				
4 Ton	7/8" [22.23]	5/8" [15.88]	Same as Liquid Line Size Table				
		3/4" [19.05]	Same as Liquid Line Size Table				
		7/8" [22.23]*	Same as Liquid Line Size Table				
5 Ton	7/8" [22.23]	3/4" [19.05]	Same as Liquid Line Size Table				
		7/8" [22.23]*	Same as Liquid Line Size Table				
		1-1/8" [28.58]	NA				

NOTES: *Standard line size
 N/A - Application not recommended.

TABLE 5
SUCTION LINE SIZING (R-410A)

SUCTION LINE SIZE - OUTDOOR UNIT BELOW INDOOR COIL							
R-410A System Capacity Model	Line Size Connection Size (Inch I.D.) [mm]	Line Size (Inch O.D.) [mm]	Suction Line Size				
			Outdoor Unit BELOW Indoor Coil (Heat Pumps)				
			Total Equivalent Length - Feet [m]				
			25 [7.62]	50 [15.24]	75 [22.86]	100 [30.48]	125 [45.72]
1 1/2 Ton	3/4" [19.05]	5/8" [15.88]	Same as Liquid Line Size Table				
		3/4" [19.05]*	NA				
		7/8" [22.23]	NA				
2 Ton	3/4" [19.05]	5/8" [15.88]	Same as Liquid Line Size Table				
		3/4" [19.05]*	Same as Liquid Line Size Table		NA		
		7/8" [22.23]	NA				
2 1/2 Ton	3/4" [19.05]	5/8" [15.88]	Same as Liquid Line Size Table				
		3/4" [19.05]*	Same as Liquid Line Size Table				
		7/8" [22.23]	Same as Liquid Line Size Table		NA		
3 Ton	3/4" [19.05]	5/8" [15.88]	Same as Liquid Line Size Table				
		3/4" [19.05]*	Same as Liquid Line Size Table				
		7/8" [22.23]	Same as Liquid Line Size Table				
3 1/2 Ton	7/8" [22.23]	5/8" [15.88]	Same as Liquid Line Size Table				
		3/4" [19.05]	Same as Liquid Line Size Table				
		7/8" [22.23]*	Same as Liquid Line Size Table				
4 Ton	7/8" [22.23]	5/8" [15.88]	Same as Liquid Line Size Table				
		3/4" [19.05]	Same as Liquid Line Size Table				
		7/8" [22.23]*	Same as Liquid Line Size Table				
5 Ton	7/8" [22.23]	3/4" [19.05]	Same as Liquid Line Size Table				
		7/8" [22.23]*	Same as Liquid Line Size Table				
		1-1/8" [28.58]	NA				

NOTES: *Standard line size
 N/A - Application not recommended.

8.0 DEMAND DEFROST CONTROL AND HIGH/LOW PRESSURE CONTROLS

The demand defrost control is a printed circuit board assembly consisting of solid state control devices with electro-mechanical outputs. The demand defrost control monitors the outdoor ambient temperature, outdoor coil temperature, and the compressor run-time to determine when a defrost cycle is required.

Enhanced Feature Demand Defrost Control: Has high and low pressure control inputs with unique pressure switch logic built into the microprocessor to provide compressor and system protection without nuisance lock-outs. Cycles the compressor off for 5 seconds at the beginning and end of the defrost cycle to eliminate the increased compressor noise caused by rapidly changing system pressures when the reversing valve switches. See section 8.7 for diagnostic flash codes for the two diagnostic LED's provided on the control.

8.1 DEFROST INITIATION

A defrost will be initiated when the three conditions below are satisfied:

- 1) The outdoor coil temperature is below 35°F.
- 2) The compressor has operated for at least 34 minutes with the outdoor coil temperature below 35°F.
- 3) The measured difference between the ambient temperature and the outdoor coil temperature exceeds a certain threshold.

Additionally, a defrost will be initiated if six hours of accumulated compressor run-time has elapsed without a defrost with the outdoor coil temperature below 35°F.

8.2 DEFROST TERMINATION

Once a defrost is initiated, the defrost will continue until fourteen minutes has elapsed or the coil temperature has reached the terminate temperature. The terminate temperature is factory set at 70°F, although the temperature can be changed to 50°F, 60°F, 70°F or 80°F by relocating a jumper on the board.

8.3 TEMPERATURE SENSORS

The coil sensor is clipped to the top tube on the outdoor coil at the point feed by the distribution tubes from the expansion device (short 3/8" dia. tube). The air sensor is located on the defrost control board.

If the ambient sensor fails the defrost control will initiate a defrost every 34 minutes with the coil temperature below 35°F.

If the coil sensor fails the defrost control will not initiate a defrost.

8.4 TEST MODE

The test mode is initiated by shorting the TEST pins. In this mode of operation, the enable temperature is ignored and all timers are sped up by a factor of 240. To initiate a manual defrost, short the TEST pins. Remove the short when the system switches to defrost mode. The defrost will terminate on time (14 minutes) or when the termination temperature has been achieved. Short TEST pins again to terminate the defrost immediately.

8.5 TROUBLE SHOOTING DEMAND DEFROST OPERATION

Set the indoor thermostat select switch to heat and thermostat lever to a call for heat.

Jumper the "test pins" to put the unit into defrost. If the unit goes into defrost and comes back out of defrost, the indication is that the control is working properly.

If the unit did not go into defrost using the test pins, check to ensure that 24V is being supplied to the control board. If 24V is present then replace the control.

8.6 HIGH/LOW PRESSURE CONTROL MONITORING

Status of high and low pressure controls is monitored by the enhanced feature demand defrost control and the following actions are taken.

High Pressure Control (optional) – Provides active protection in both cooling and heating modes at all outdoor ambient temperatures. The high pressure control is an automatic reset type and opens at approximately 610 psig and closes at approximately 420 psig. The compressor and fan motor will stop when the high pressure control opens and will start again if the high side pressure drops to approximately 420 psig when the automatic reset high pressure control resets. If the high pressure control opens 3 times within a particular call for heating or cooling operation, the defrost control will lock out compressor and outdoor fan operation.

Low Pressure Control (standard) – Provides active protection in both heating and cooling modes at all outdoor ambient temperatures. The low pressure control is an automatic reset type and opens at approximately 15 psig and closes at approximately 40 psig. Operation is slightly different between cooling and heating modes.

Cooling Mode: The compressor and fan motor will stop when the low pressure control opens and will start again when the low side pressure rises to approximately 40 psig when the low pressure control automatically resets. If the low pressure switch opens 3 times within a particular call for cooling operation, the defrost control will lock out compressor and outdoor fan operation.

Heating Mode: The compressor and fan motor will stop when the low pressure control opens and will start again when the low side pressure rises to approximately 40 psig when the low pressure control automatically resets. If the low pressure switch trips 3 times within 120 minutes of operation during a particular call for heating operation, the defrost control will lock out compressor and outdoor fan operation. If the lock-out due to low pressure occurs at an outdoor ambient temperature below 5°F, the defrost control will automatically exit the lock-out mode when the outdoor ambient temperature rises to 5°F. This feature is necessary since the low pressure control could possibly have opened due to the outdoor ambient being very low rather than an actual system fault.

Exiting Lock-Out Mode: To exit the lock-out mode, remove 24 volts to the defrost control by removing power to indoor air-handler/furnace or by shorting the two defrost control test pins together.

8.7 ENHANCED FEATURE DEFROST CONTROL DIAGNOSTIC CODES

LED 1	LED 2	Control Board Status
OFF	OFF	No Power
ON	ON	Coil Sensor Failure
OFF	ON	Ambient Sensor Failure
FLASH	FLASH	Normal
OFF	FLASH	Low Pressure Lockout (short test pins to reset)
FLASH	OFF	High Pressure Lockout (short test pins to reset)
ON	FLASH	Low Pressure Control Open
FLASH	ON	High Pressure Control Open
Alternate Flashing		5 Minute Time Delay

9.0 START-UP – CHECKING AIRFLOW

The air distribution system has the greatest effect on airflow. The duct system is totally controlled by the contractor. For this reason, the contractor should use only industry-recognized procedures. The correct air quantity is critical to air conditioning systems. Proper operation, efficiency, compressor life, and humidity control depend on the correct balance between indoor load and outdoor unit capacity. Excessive indoor airflow increases the possibility of high humidity problems. Low indoor airflow reduces total capacity and causes coil icing. Serious harm can be done to the compressor by low airflow, such as that caused by refrigerant flooding. Heat pump systems require a specified airflow. Each ton of cooling requires between 375 and 450 cubic feet of air per minute (CFM). See the manufacturer's spec sheet for rated airflow for the system being installed. Duct design and construction should be carefully done. System performance can be lowered dramatically through bad planning or workmanship. Air supply diffusers must be selected and located carefully. They must be sized and positioned to deliver treated air along the perimeter of the space. If they are too small for their intended airflow, they become noisy. If they are not located properly, they cause drafts. Return air grilles must be properly sized to carry air back to the blower. If they are too small, they also cause noise. The installers

should balance the air distribution system to ensure proper quiet airflow to all rooms in the home. This ensures a comfortable living space.

These simple mathematical formulas can be used to determine the CFM in a residential or light commercial system. Electric resistance heaters can use:

$$CFM = \frac{\text{volts} \times \text{amps} \times 3.413}{SHC \times \text{temp rise}}$$

Gas furnaces can use:

$$CFM = \frac{\text{Output Capacity in BTUH}^*}{SHC \times \text{temp rise}}$$

*Refer to furnace data plate for furnace output capacity. SHC = Sensible Heat Constant (see table below), an air velocity meter or airflow hood can give a more accurate reading of the system CFM. The measurement for temperature rise should be performed at the indoor coil inlet and near the outlet, but out of direct line of sight of the heater element or heat exchanger. For best results, measure air temperature at multiple points and average the measurements to obtain coil inlet and outlet temperatures.

Altitude (feet)	SENSIBLE HEAT CONSTANT (SHC)	ALTITUDE (FEET)	SENSIBLE HEAT CONSTANT (SHC)
Sea Level	1.08	6000	0.87
500	1.07	7000	0.84
1000	1.05	8000	0.81
2000	1.01	9000	0.78
3000	0.97	10000	0.75
4000	0.94	15000	0.61
5000	0.90	20000	0.50

10.0 EVACUATION AND LEAK TESTING

10.1 EVACUATION PROCEDURE

Evacuation is the most important part of the entire service procedure. The life and efficiency of the equipment is dependent upon the thoroughness exercised by the serviceman when evacuating air and moisture from the system.

Air or nitrogen in the system causes high condensing temperatures and pressure, resulting in increased power input and non-verifiable performance.

Moisture chemically reacts with the refrigerant and oil to form corrosive hydrofluoric acid. This attacks motor windings and parts, causing breakdown.

- After the system has been leak-checked and proven sealed, connect the vacuum pump and evacuate system to 500 microns and hold 500 microns or less for at least 15 minutes. The vacuum pump must be connected to both the high and low sides of the system by connecting to the two pressure ports. Use the largest size connections available since restrictive service connections may lead to false readings because of pressure drop through the fittings.
- After adequate evacuation, open both service valves by removing both brass service valve caps with an adjustable wrench. Insert a 3/16" [5 mm] or 5/16" [8 mm] hex wrench into the stem and turn counterclockwise until the wrench stops.
- At this time gauges must be connected to the access fitting on the liquid line (small) service valve and the common suction port connected to the common suction line between the reversing valve and compressor to check and adjust charge.

IMPORTANT: Compressors (especially scroll type) should never be used to evacuate the air conditioning system because internal electrical arcing may result in a damaged or failed compressor. Never run a scroll compressor while the system is in a vacuum or compressor failure will occur.

10.2 FINAL LEAK TESTING

After the unit has been properly evacuated and service valves opened, a halogen leak detector should be used to detect leaks in the system. All piping within the heat pump, evaporator, and interconnecting tubing should be checked for leaks. If a leak is detected, the refrigerant should be recovered before repairing the leak. The Clean Air Act prohibits releasing refrigerant into the atmosphere.

11.0 CHECKING REFRIGERANT CHARGE

Charge for all systems should be checked against the Charging Chart inside the access panel cover.

WARNING

The top of the scroll compressor shell is hot. Touching the compressor top may result in serious personal injury.

IMPORTANT: Use factory-approved charging method as outlined on the next 4 pages to ensure proper system charge.

NOTICE

The optimum refrigerant charge for any outdoor unit matched with a CFL/CFM/H*L indoor coil/air handler is affected by the application. Therefore, charging data has been developed to assist the field technician in optimizing the charge for all mounting configurations (UF – Upflow, DF – downflow, LH – Left Hand Discharge, and RH – Right Hand Discharge). Refer to the charging chart inside the access panel cover on the unit and choose the appropriate column for the specific application being installed or serviced. New installations utilizing either a CFL/CFM indoor coil installed on a gas furnace or an H*L air handler in the downflow or horizontal right hand discharge may require removal of refrigerant since the factory charge could result in an overcharge condition.

11.1 CHARGING UNITS WITH R-410A REFRIGERANT

CAUTION

R-410A pressures are approximately 60% higher (1.6 times) than R-22 pressures. Use appropriate care when using this refrigerant. Failure to exercise care may result in equipment damage or personal injury.

Charge for all systems should be checked against the Charging Chart inside the access panel cover.

IMPORTANT: Do not operate the compressor without charge in the system.

Addition of R-410A will raise high-side pressures (liquid, and discharge).

NOTICE

System maintenance is to be performed by a qualified and certified technician.

The following method is used for charging systems in the cooling and heating mode. All steps listed should be performed to insure proper charge has been set. For measuring pressures, the service valve port on the liquid valve (small valve) and the service port on the suction line between the reversing valve and compressor are to be used.

CONFIRM ID AIR FLOW & COILS ARE CLEAN

Confirm adequate Indoor supply air flow prior to starting the system. See the Technical Specification sheet for rated air flow for each ID/OD unit match. Air filter(s) and coils (indoor & outdoor) are to be clean and free of frost prior to starting the system. Supply Air flow must be between 375 and 450 cfm per rated cooling ton prior to adjusting system charge. If a humidification system is installed disengage it from operating prior to charge adjustment. Refer to the “Checking Airflow” section of this manual for further instruction.

NOTICE

Verify system components are matched according to the outdoor unit Specification Sheet.

11.2 MEASUREMENT DEVICE SETUP

- Step 1. With an R410A gauge set, attach the high pressure hose to the access fitting on the liquid line (small) service valve at the OD unit.
- Step 2. Attach the low pressure hose to the common suction port connected to the common suction line between the reversing valve and compressor.
- Step 3. Attach a temperature probe within 6" outside of the unit on the copper liquid line (small line). For more accurate measurements clean the copper line prior to measurement and use a calibrated clamp on temperature probe or an insulated surface thermocouple.

11.3 CHARGING BY WEIGHT

▲ NOTICE

ADJUST THE SYSTEM CHARGE BY WEIGHT FOR THE STRAIGHT LENGTH OF THE REFRIGERANT LINE SET.

For a new installation, evacuation of interconnecting tubing and indoor coil is adequate; otherwise, evacuate the entire system. Use the factory charge shown in "Electrical and Physical Data" on page 6 of these instructions or on the unit data plate. Note that the charge value includes charge required for 15 ft. [4.6 m] of standard-size inter-connecting liquid line without a filter drier. Calculate actual charge required with installed liquid line size and length using:

1/4" [6.4 mm] O.D. = .3 oz./ft. [8.5 g/.30 m]
5/16" [7.9 mm] O.D. = .4 oz./ft. [11.3 g/.30 m]
3/8" [9.5 mm] O.D. = .6 oz./ft. [17.0 g/.30 m]
1/2" [12.7 mm] O.D. = 1.2 oz./ft. [34.0 g/.30 m]
Add 6 oz. for field-installed filter drier.

With an accurate scale (+/- 1 oz. [28.3 g]) or volumetric charging device, adjust charge difference between that shown on the unit data plate and that calculated for the new system installation. If the entire system has been evacuated, add the total calculated charge.

IMPORTANT:Charging by weight is not always accurate since the application can affect the optimum refrigerant charge. Charging by weight is considered a starting point ONLY. Always check the charge by using the charging chart and adjust as necessary. CHARGING BY LIQUID SUB-COOLING MUST BE USED FOR FINAL CHARGE ADJUSTMENT.

FIGURE 3

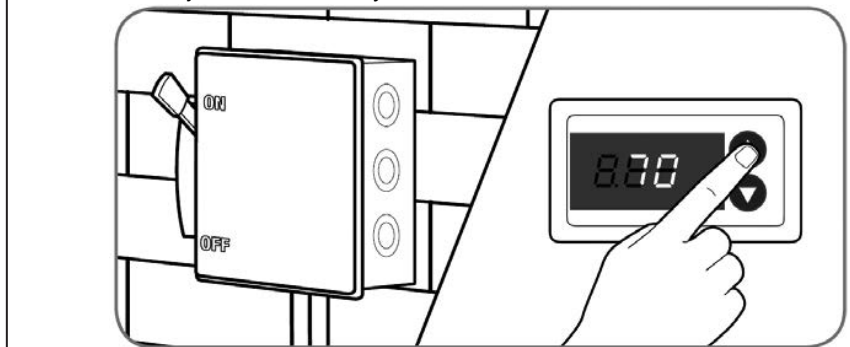

With thermostat in the "Off" position, turn the power on to the furnace or air handler and the heat pump. Start the heat pump and the furnace or air handler with the thermostat.

11.4 GROSS CHARGING BY PRESSURES

- Step 1. Following air flow verification and charge weigh in, run the unit for a minimum of 15 minutes prior to noting pressures and temperature.

IMPORTANT:Indoor conditions as measured at the indoor coil must be within 2°F of the following during gross charge (pressure) evaluation:

Cooling Mode: 80°F Dry Bulb
Heating Mode: 70°F Dry Bulb

NOTICE

If the Indoor temperature is above or below this range, run the system to bring the temperature down or run the electric heat/furnace to bring the temperature within this range. System pressure values provided in the Charge Chart for outdoor dry bulbs corresponding to conditions outside of ranges listed below, are provided as reference ONLY.

- Step 2. Note the Outdoor Dry Bulb Temperature, ODDB°F = _____°F. Unit charging is recommended under the following outdoor conditions ONLY:
Cooling Mode ONLY: 55°F outdoor dry bulb and above
Heating Mode ONLY: Between 40°F and 60°F outdoor dry bulb
- Step 3. Locate and note the design pressures. The correct liquid and vapor pressures are found at the intersection of the Installed system and the outdoor ambient temperature on the Charging Chart located on the inside of the control box cover of the outdoor unit.
Liquid Pressure: = _____psig; Vapor Pressure = _____psig

NOTICE

The refrigerant pressures provided are for gross charge check ONLY. These pressure values are typical, but may vary due to application. Evaporator (indoor coil in cooling mode / outdoor coil in heating mode) load will cause pressures to deviate. Notice that all systems have unique pressure curves. The variation in the slope and value is determined by the component selection for that indoor/outdoor matched system. The variation from system to system seen in the table is normal. The values listed are for the applicable indoor coil match ONLY!

- Step 4. If the measured liquid pressure is below the listed requirement for the given outdoor and indoor conditions, add charge. If the measured liquid pressure is above the listed requirement for the given Outdoor and Indoor conditions remove charge.

11.5 FINAL CHARGE BY SUB-COOLING

- Step 1. After gross charging note the designed Sub-Cool value. The correct sub-cooling value is found at the intersection of the Installed system and the outdoor ambient temperature on the Charging Chart located on the inside of the control box cover of the outdoor unit.

SC° from Charging Chart = _____°F.

IMPORTANT: Indoor conditions as measured at the indoor coil are required to be between 70°F and 80°F dry bulb for fine tune unit charge adjustment. Unit charging is recommended under the following outdoor conditions ONLY:

Cooling Mode ONLY: 55°F outdoor dry bulb and above

Heating Mode ONLY: Between 40°F and 60°F outdoor dry bulb

NOTICE

If the Indoor temperature is above or below the recommended range, run the system to bring the temperature down or run the electric heat/furnace to bring the temperature up. System sub-cooling values provided in the Charge Chart for outdoor dry bulbs corresponding to conditions outside of the above range, are provided as reference ONLY.

- Step 2. Note the measured Liquid Pressure, P_{liq} = _____psig, as measured from the liquid (small) service valve. Use the pressure temperature chart on the next page to note the corresponding saturation temperature for R410A at the measured liquid pressure.
Liquid Saturation Temperature, SAT°F= _____°F.

TABLE 6

SATURATION TEMP (Deg. F)	R-410A PSIG	SATURATION TEMP (Deg. F)	R-410A PSIG	SATURATION TEMP (Deg. F)	R-410A PSIG	SATURATION TEMP (Deg. F)	R-410A PSIG
-150	-	-30	17.9	35	107.5	100	317.4
-140	-	-25	22	40	118.5	105	340.6
-130	-	-20	26.4	45	130.2	110	365.1
-120	-	-15	31.3	50	142.7	115	390.9
-110	-	-10	36.5	55	156.0	120	418.0
-100	-	-5	42.2	60	170.1	125	446.5
-90	-	0	48.4	65	185.1	130	476.5
-80	-	5	55.1	70	201.0	135	508.0
-70	-	10	62.4	75	217.8	140	541.2
-60	0.4	15	70.2	80	235.6	145	576.0
-50	5.1	20	78.5	85	254.5	150	612.8
-40	10.9	25	87.5	90	274.3		
-35	14.2	30	97.2	95	295.3		

Step 3. Note the liquid line temperature, $Liq^{\circ} = \text{_____}^{\circ}\text{F}$, as measured from a temperature probe located within 6" outside of the unit on the copper liquid line (small line). It is recommended to use a calibrated clamp on temperature probe or an insulated surface thermocouple.

Step 4. Subtract the liquid line temperature (Step 3) from the saturation temperature (Step 2) to calculate Sub-Cooling. $SAT^{\circ}\text{F} \text{_____} - Liq^{\circ} \text{_____} = SC^{\circ} \text{_____}$

Step 5. Adjust Charge to obtain the specified sub-cooling value. If the measured sub-cool is below the listed requirement for the given outdoor and indoor conditions, add charge. If the measured sub-cool is above the listed requirement for the given outdoor and indoor conditions remove charge.

▲ NOTICE

Systems should not be fine tune charged below 40°F outdoor dry bulb.

IMPORTANT: Excessive use of elbows in the refrigerant line set can produce excessive pressure drop. Follow industry best practices for installation. Installation and commissioning of this equipment is to be performed by trained and qualified HVAC professionals. For technical assistance contact your Distributor Service Coordinator.

11.6 FINISHING UP INSTALLATION

- Disconnect pressure gauges from pressure ports; then replace the pressure port caps and tighten adequately to seal caps. **Do not over tighten.**
- Replace the service valve caps finger-tight and then tighten with an open-end wrench adequately to seal caps. **Do not over tighten.**
- Replace control box cover and service panel and install screws to secure service panel.
- Restore power to unit at disconnect if required.
- Configure indoor thermostat per the thermostat installation instructions and set thermostat to desired mode and temperature.

12.0 ELECTRICAL WIRING

NOTE: Check all wiring to be sure connections are securely fastened, electrically isolated from each other and that the unit is properly grounded.

⚠ WARNING

Turn off electric power at the fuse box or service panel before making any electrical connections.

Also, the ground connection must be completed before making line voltage connections. Failure to do so can result in electrical shock, severe personal injury or death.

Field wiring must comply with the National Electric Code (C.E.C. in Canada) and any applicable local code.

12.1 POWER WIRING

It is important that proper electrical power from a commercial utility is available at the heat pump contactor. Voltage ranges for operation are shown in Table 6.

Install a branch circuit disconnect within sight of the unit and of adequate size to handle the starting current (see Table 1).

Power wiring must be run in a rain-tight conduit. Conduit must be run through the connector panel below the access cover (see Figure 1) and attached to the bottom of the control box.

Connect power wiring to contactor located in outdoor heat pump electrical box. (See wiring diagram attached to unit access panel.)

Check all electrical connections, including factory wiring within the unit and make sure all connections are tight.

DO NOT connect aluminum field wire to the contactor terminals.

12.2 GROUNDING

A grounding lug is provided near the contactor for a ground wire.

⚠ WARNING

The unit must be permanently grounded. Failure to do so can cause electrical shock resulting in severe personal injury or death.

TABLE 7
VOLTAGE RANGES (60 HZ)

Nameplate Voltage	Operating Voltage Range at Copeland Maximum Load Design Conditions for Compressors
208/230 (1 Phase)	187 - 253

12.3 CONTROL WIRING

(See Figure 7)

If the low voltage control wiring is run in conduit with the power supply, Class I insulation is required. Class II insulation is required if run separate. Low voltage wiring may be run through the insulated bushing provided in the 7/8" [22.2 mm] hole in the base panel, up to and attached to the pigtails from the bottom of the control box. Conduit can be run to the base panel if desired by removing the insulated bushing.

A thermostat and a 24 volt, 40 VA minimum transformer are required for the control circuit of the condensing unit. The furnace or the air handler transformer may be used if sufficient. See the wiring diagram for reference.

FIGURE 4
CONTROL WIRING FOR AIR HANDLER

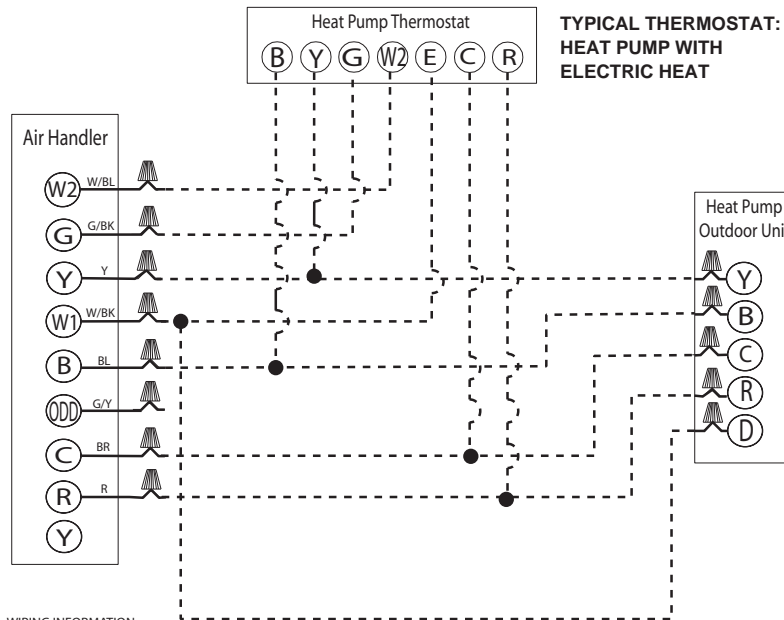

TYPICAL THERMOSTAT:
HEAT PUMP WITH
ELECTRIC HEAT

NOTES:

1. Jumper "E" to "W2" to transfer control of supplemental heat to 1st stage when the emergency heat switch is on.
2. This wire turns on heat for defrost, omit for most economical operation.
3. Wire with colored tracing stripe.

WIRING INFORMATION
Line Voltage
-Field Installed - - -
-Factory Standard ———

NOTE: RED WIRE REQUIRED WITH RANCO DDL DEMAND DEFROST CONTROL.

13.0 FIELD INSTALLED ACCESSORIES

13.1 COMPRESSOR CRANKCASE HEATER (CCH)

While scroll compressors usually do not require crankcase heaters, there are instances when a heater should be added. Refrigerant migration during the off cycle can result in a noisy start up. Add a crankcase heater to minimize refrigeration migration, and to help eliminate any start up noise or bearing "wash out."

TABLE 8
MAXIMUM SYSTEM CHARGE VALUES 15 SEER

15 SEER Model Size	Compressor Model Number	Charge Limit Without Crankcase Heat (1 Phase)
18	ZP16K5E	9.6 lbs. [66.2 kPa]
24	ZP20K5E	9.6 lbs. [66.2 kPa]
30	ZP24K5E	9.6 lbs. [66.2 kPa]
36	ZP31K5E	9.6 lbs. [66.2 kPa]
42	ZP34K5E	12 lbs. [82.7 kPa]

NOTE: Model sizes 48 and 60 have a factory installed crankcase heater.

NOTE: The installation of a crankcase heater is recommended if the system charge exceeds the values in Table 8.

All heaters are located on the lower half of the compressor shell. Its purpose is to drive refrigerant from the compressor shell during long off cycles, thus preventing damage to the compressor during start-up.

At initial start-up or after extended shutdown periods, make sure the heater is energized for at least 12 hours before the compressor is started. (Disconnect switch on and wall thermostat off.)

13.2 LOW AMBIENT CONTROL (LAC) – COOLING MODE ONLY - RXAD-A08

This component senses compressor head pressure and shuts the heat pump fan off when the head pressure drops to approximately 220 PSIG [1516.8 kPa]. This allows the unit to build a sufficient head pressure at lower ambient in order to maintain system balance and obtain improved capacity. Low ambient control should be used on all equipment operated below 70°F [21.1°C] ambient.

13.3 HIGH PRESSURE CONTROL (HPC)

This control keeps the compressor from operating in pressure ranges which can cause damage to the compressor. This control is in the low voltage control circuit.

High pressure control (HPC) is a manual reset which opens near 610 PSIG [4205.8 kPa]. Do not reset arbitrarily without first determining what caused it to trip.

13.4 HEAT PUMP THERMOSTAT WARNING LIGHT KIT RXPX-D01

This component senses a compressor lock out and tells the thermostat service light to come on. This will let the homeowner know that service is needed on the system.

NOTE: Warning light on thermostat will come on during a 5 minute compressor time delay and for 5 seconds during defrost while the compressor is off. Homeowner should only be concerned if light stays on for more than 5 minutes.

14.0 SERVICE

14.1 SINGLE-POLE COMPRESSOR CONTACTOR (CC)

CAUTION
Single-pole contactors are used on all standard single-phase units up through 5 tons. Caution must be exercised when servicing as only one leg of the power supply is broken with the contactor.

15.0 TROUBLE SHOOTING

In diagnosing common faults in the heat pump system, develop a logical thought pattern as used by experienced technicians. The charts which follow are not intended to be an answer to all problems but only to guide the technician's thinking. Through a series of yes and no answers, follow the logical path to a likely conclusion.

A novice technician should use these charts like a road map. Remember that the chart should clarify a logical path to the problem's solution.

15.1 ELECTRICAL CHECKS FLOW CHART

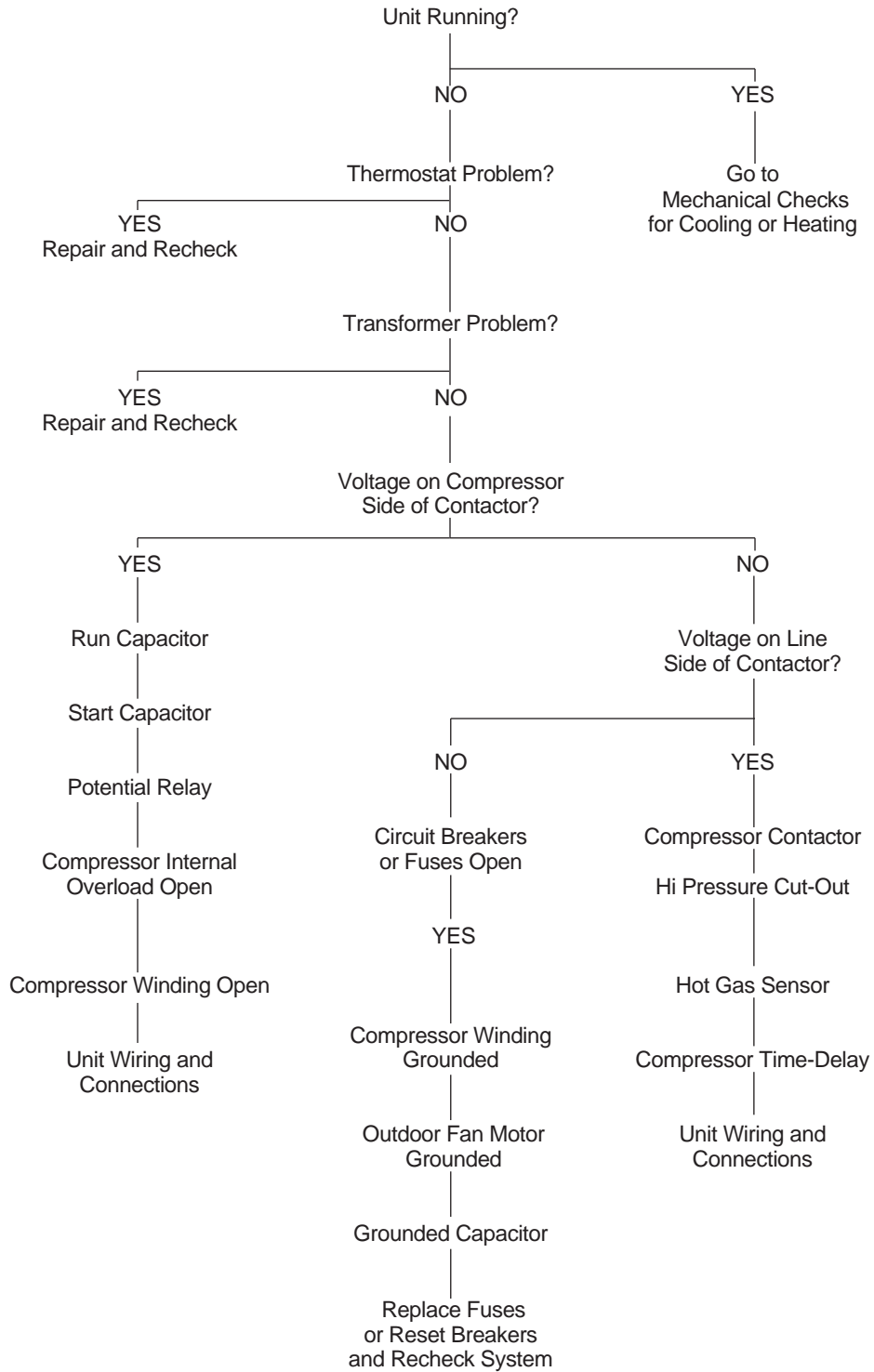

15.2 COOLING MECHANICAL CHECKS FLOW CHART

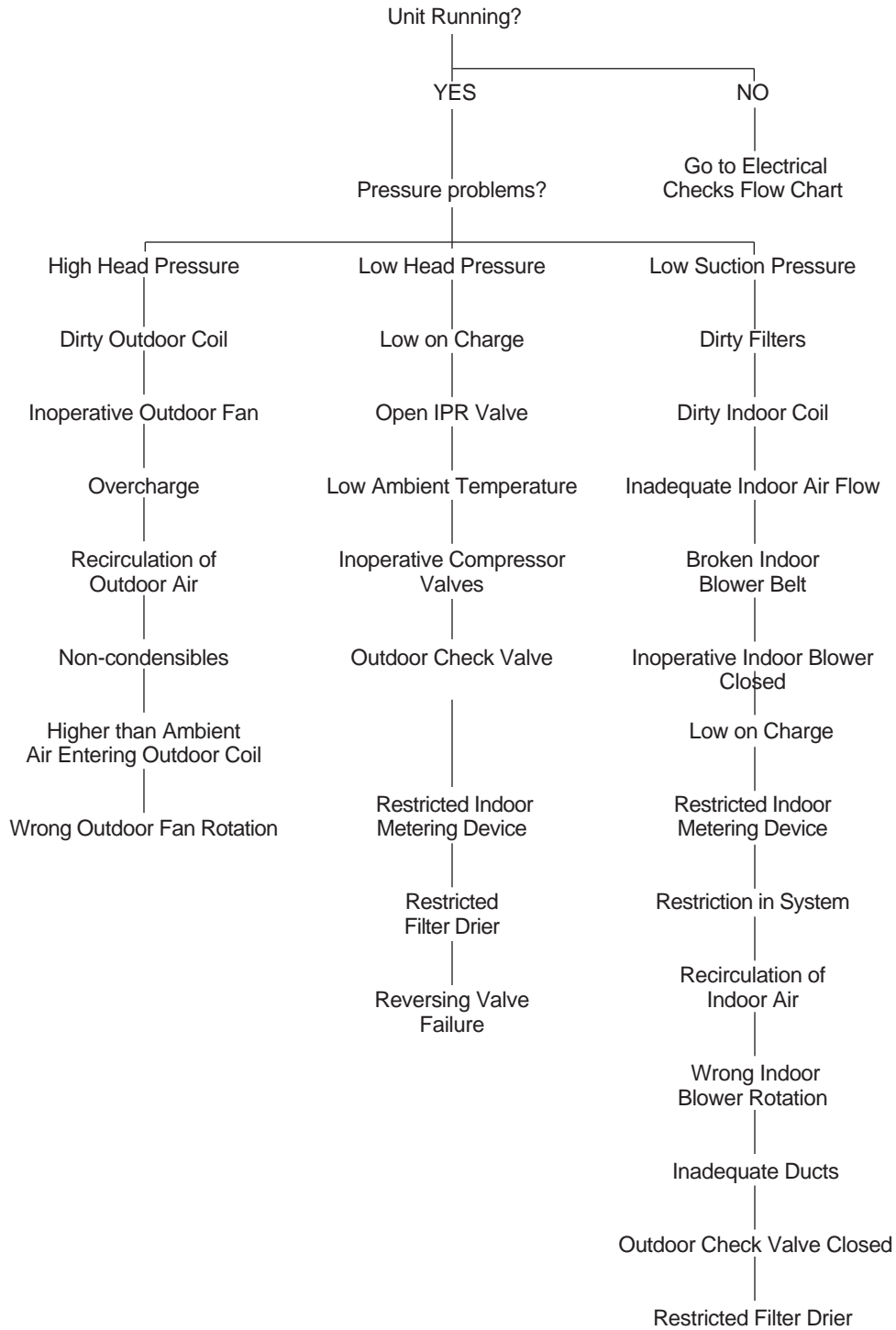

15.3 HEATING MECHANICAL CHECKS FLOW CHART

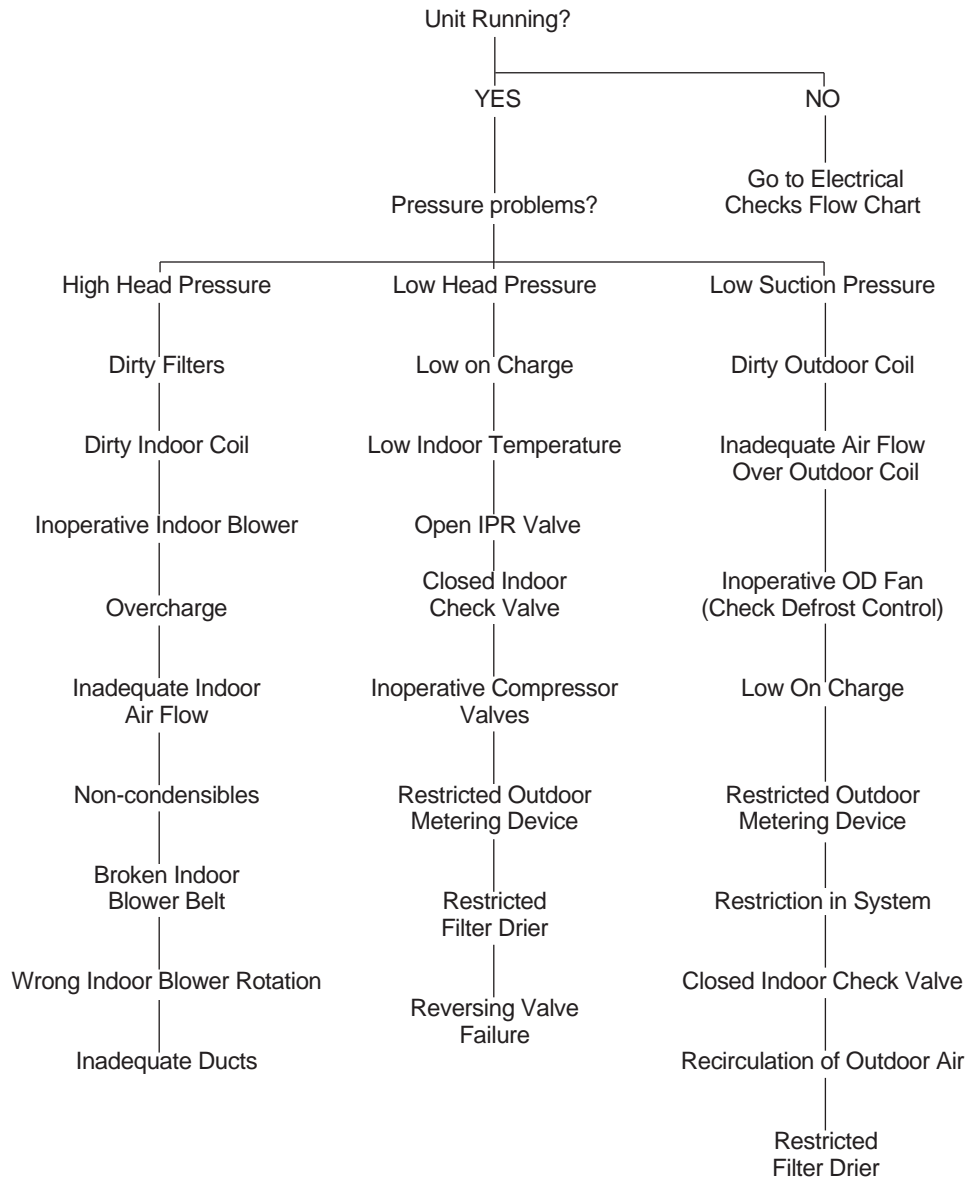

15.4 DEFROST MECHANICAL CHECKS FLOW CHART

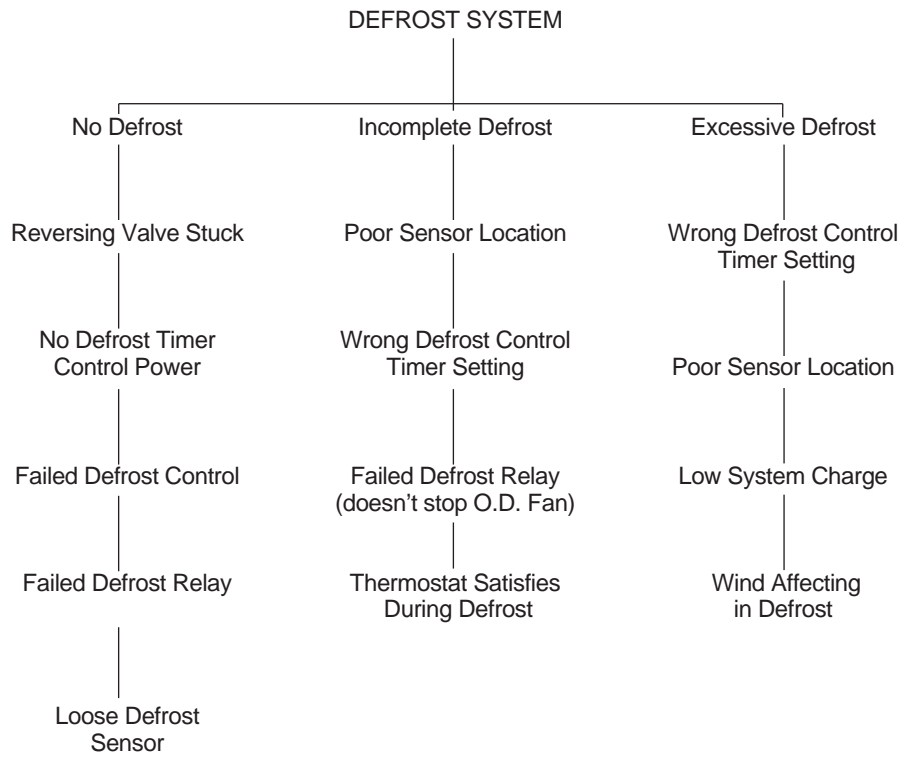

System Problem	Discharge Pressure	Suction Pressure	Sub-cooling	Compressor Amps
Overcharge *	High	Low/Normal	High	High
Undercharge	Low	Low	Low	Low
Liquid Line Restriction **	Low	Low	High	Low
Low Evaporator Airflow	High	Low	Low	Low
Dirty outdoor Coil	High	High/Normal	Low	High
Low Outside Ambient temperature	Low	Low	High	Low
TXV sensing bulb charge lost	Low	Low	High	Low
Poorly Insulated Sensing Bulb	High	High	Low	High
<p>* Superheat "normal" values may range anywhere from ~6 to ~20 degrees. ** High ratio of Discharge Pressure to Suction Pressure</p>				

15.5 GENERAL TROUBLE SHOOTING CHART

▲ WARNING

Disconnect all power to unit before servicing. Contactor may break only one side. Failure to shut off power can cause electrical shock resulting in personal injury or death.

SYMPTOM	POSSIBLE CAUSE	REMEDY
Unit will not run	<ul style="list-style-type: none"> Power off or loose electrical connection Thermostat out of calibration-set too high Defective contactor Blown fuses / tripped breaker Transformer defective High pressure control open (if provided) 	<ul style="list-style-type: none"> Check for correct voltage at contactor in condensing unit Reset Check for 24 volts at contactor coil - replace if contacts are open Replace fuses / reset breaker Check wiring-replace transformer Reset-also see high head pressure remedy-The high pressure control opens at 450 PSIG [3102 kPa]
Outdoor fan runs, compressor doesn't	<ul style="list-style-type: none"> Run or start capacitor defective Start relay defective Loose connection Compressor stuck, grounded or open motor winding, open internal overload. Low voltage condition 	<ul style="list-style-type: none"> Replace Replace Check for correct voltage at compressor - check & tighten all connections Wait at least 2 hours for overload to reset. If still open, replace the compressor. Add start kit components
Insufficient cooling	<ul style="list-style-type: none"> Improperly sized unit Improper indoor airflow Incorrect refrigerant charge Air, non-condensibles or moisture in system 	<ul style="list-style-type: none"> Recalculate load Check - should be approximately 400 CFM [188.8 L/s] per ton. Charge per procedure attached to unit service panel Recover refrigerant, evacuate & recharge, add filter drier
Compressor short cycles	<ul style="list-style-type: none"> Incorrect voltage Defective overload protector Refrigerant undercharge 	<ul style="list-style-type: none"> At compressor terminals, voltage must be $\pm 10\%$ of nameplate marking when unit is operating. Replace - check for correct voltage Add refrigerant
Registers sweat	<ul style="list-style-type: none"> Low indoor airflow 	<ul style="list-style-type: none"> Increase speed of blower or reduce restriction - replace air filter
High head-low vapor pressures	<ul style="list-style-type: none"> Restriction in liquid line, expansion device or filter drier Flowcheck piston size too small Incorrect capillary tubes 	<ul style="list-style-type: none"> Remove or replace defective component Change to correct size piston Change coil assembly
High head-high or normal vapor pressure - Cooling mode	<ul style="list-style-type: none"> Dirty outdoor coil Refrigerant overcharge Outdoor fan not running Air or non-condensibles in system 	<ul style="list-style-type: none"> Clean coil Correct system charge Repair or replace Recover refrigerant, evacuate & recharge
Low head-high vapor pressures	<ul style="list-style-type: none"> Flowcheck piston size too large Defective Compressor valves Incorrect capillary tubes 	<ul style="list-style-type: none"> Change to correct size piston Replace compressor Replace coil assembly
Low vapor - cool compressor - iced indoor coil	<ul style="list-style-type: none"> Low indoor airflow Operating below 65°F [18.3°C] outdoors Moisture in system 	<ul style="list-style-type: none"> Increase speed of blower or reduce restriction - replace air filter Add Low Ambient Kit Recover refrigerant - evacuate & recharge - add filter drier
High vapor pressure	<ul style="list-style-type: none"> Excessive load Defective compressor 	<ul style="list-style-type: none"> Recheck load calculation Replace
Fluctuating head & vapor pressures	<ul style="list-style-type: none"> TEV hunting Air or non-condensibles in system 	<ul style="list-style-type: none"> Check TEV bulb clamp - check air distribution on coil - replace TEV Recover refrigerant, evacuate & recharge
Gurgle or pulsing noise at expansion device or liquid line	<ul style="list-style-type: none"> Air or non-condensibles in system 	<ul style="list-style-type: none"> Recover refrigerant, evacuate & recharge

15.6 SERVICE ANALYZER CHART

COMPRESSOR OVERHEATING		
SYMPTOMS	POSSIBLE CAUSE	CHECK/REMEDIES
High superheat	Low charge	Check system charge
	Faulty metering device	Restricted cap tube, TEV (TXV)
		Power element superheat adjustment
		Foreign matter stopping flow
	High internal load	Hot air (attic) entering return
		Heat source on; mis-wired or faulty control
	Restriction in liquid line	Drier plugged
		Line kinked
	Low head pressure	Low charge
		Operating in low ambient temperatures
Suction or liquid line subjected to high heat source	Hot attic	
	Hot water line	
Low voltage	Loose wire connections	Check wiring
	Dirty or pitted compressor contactor contacts	Replace contactor
	Power company problem, transformer	Have problem corrected before diagnosis continues
	Undersized wire feeding unit	Correct and complete diagnosis
High voltage	Power company problem	Have problem corrected
High head pressure	Overcharge	Check system charge
	Dirty heat pump coil	Clean coil
	Faulty or wrong size heat pump fan motor	Replace fan motor
	Faulty fan blade or wrong rotation	Replace fan blade
		Replace with correct rotation motor
	Recirculation of air	Correct installation
	Additional Heat Source	Check for dryer vent near unit
		Check for recirculation from other equipment
Non-condensibles	Recover refrigerant, Evacuate and recharge system	
Equipment not matched	Correct mis-match	
Short cycling of compressor	Faulty pressure control	Replace pressure control
	Loose wiring	Check unit wiring
	Thermostat	Located in supply air stream
		Differential setting too close
		Customer misuse
	TEV	Internal foreign matter
		Power element failure
		Valve too small
		Distributor tube/tubes restricted
	Capillary tube	Restricted with foreign matter
Kinked		
I.D. reduced from previous compressor failure		

SYMPTOMS	POSSIBLE CAUSE	CHECK OR REMEDIES
Short cycling of compressor (cont.)	Low charge	Check system charge
	Low evaporator air flow	Dirty coil
		Dirty filter
		Duct too small or restricted
	Faulty run capacitor	Replace
Faulty internal overload	Replace compressor	
Faulty Compressor Valves	Fast equalization/ Low pressure difference	Replace compressor and examine system to locate reason
<i>ELECTRICAL</i>		
SYMPTOMS	POSSIBLE CAUSE	CHECK OR REMEDIES
Voltage present on load side of compressor contactor and compressor won't run	Compressor start components	Check start capacitor
		Check potential relay
	Run capacitor	Check with ohmmeter
	Internal overload	Allow time to reset
	Compressor windings	Check for correct ohms
Voltage present on line side of pressor contactor only	Thermostat	Check for control voltage to com- contactor coil
	Compressor control circuit	High pressure switch
		Low pressure switch
		Ambient thermostat
		Solid state protection control or internal thermal sensors
		Compressor timed off/on control or interlock
No voltage on line side of compressor contactor	Blown fuses or tripped circuit breaker	Check for short in wiring or unit
	Improper wiring	Re-check wiring diagram
Improper voltage	High voltage	Wrong unit
		Power supply problem
	Low voltage	Wrong unit
		Power supply problem
		Wiring undersized
	Single Phasing (3 phase)	Loose connections
	Check incoming power and fusing	
<i>CONTAMINATION</i>		
SYMPTOMS	POSSIBLE CAUSE	CHECK OR REMEDIES
Moisture	Poor evacuation on installation or during service	In each case, the cure is the same. Recover refrigerant. Add filter drier, evacuate and re-charge
High head pressure	Non-condensibles air	
Unusual head and suction readings	Wrong refrigerant	
Foreign Matter- copper filings	Copper tubing cuttings	
Copper oxide	Dirty copper piping	
Welding scale	Nitrogen not used	
Soldering flux	Adding flux before seating copper part way	
Excess soft solder	Wrong solder material	

LOSS OF LUBRICATION		
SYMPTOMS	POSSIBLE CAUSE	CHECK OR REMEDIES
Compressor failures	Line tubing too long	Add oil to the recommended level
	Line tubing too large	Reduce pipe size to improve oil return
Low suction pressure	Low charge	Check system charge
	Refrigerant leaks	Repair and recharge
Cold, Noisy compressor - Slugging	Dilution of Oil with Refrigerant	Observe piping guidelines
Noisy compressor	Migration	Check crankcase heater
Cold, sweating compressor	Flooding	Check system charge
Low Load	Reduced air flow	Dirty filter
		Dirty coil
		Wrong duct size
		Restricted duct
Short cycling of compressor	Thermostat setting	Advise customer
	Faulty pressure control	Replace control
	Loose wiring	Check all control wires
	Thermostat	In supply air stream, out of calibration, Customer misuse
FLOODED STARTS		
SYMPTOMS	POSSIBLE CAUSES	CHECK OR REMEDIES
Liquid in the compressor shell	Faulty or missing crankcase heater	Replace crankcase heater
Too much liquid in system	Incorrect piping	Check Piping guidelines
	Overcharge	Check and adjust charge
SLUGGING		
SYMPTOMS	POSSIBLE CAUSES	CHECK OR REMEDIES
On start up	Incorrect piping	Review pipe size guidelines
TEV hunting when running	Oversized TEV	Check TEV application
FLOODING		
SYMPTOMS	POSSIBLE CAUSES	CHECK OR REMEDIES
Poor system control using a TEV	Loose sensing bulb	Secure the bulb and insulate
	Bulb in wrong location	Relocate bulb
	Wrong size TEV	Use correct replacement
	Improper superheat setting	Adjust, if possible; Replace, if not
Poor system control using capillary tubes	Overcharge	Check system charge
	High head pressures	Dirty heat pump
		Restricted air flow
Evaporator air flow too low	Recirculation of air	
		Adjust air flow to 400 CFM [188.8 L/s] /Ton

THERMOSTATIC EXPANSION VALVES

SYMPTOMS	POSSIBLE CAUSE	CHECK OR REMEDIES	
High Superheat, Low Suction Pressure	Moisture freezing and blocking valve	Recover charge, install filter-drier, evacuate system, recharge	
	Dirt or foreign material blocking valve	Recover charge, install filter-drier, evacuate system, recharge	
	Low refrigerant charge	Correct the charge	
	Vapor bubbles in liquid line	Remove restriction in liquid line	Correct the refrigerant charge
		Remove non-condensable gases	
		Size liquid line correctly	
	Misapplication of internally equalized valve	Use correct TEV	
	Plugged external equalizer line	Remove external equalizer line restriction	
	Undersized TEV	Replace with correct valve	
	Loss of charge from power head sensing bulb	Replace power head or complete TEV	
	Charge migration from sensing bulb to power head (Warm power head with warm, wet cloth. Does valve operate correctly now?)	Ensure TEV is warmer than sensing bulb	
Improper superheat adjustment (Only applicable to TEV with adjustable superheat settings)	Adjust superheat setting counter-clockwise		
Valve feeds too much refrigerant, with low superheat and higher than normal suction pressure	Moisture causing valve to stick open.	Recover refrigerant, replace filter-drier, evacuate system and then non-recharge	
	Dirt or foreign material causing valve to stick open	Recover refrigerant, replace filter-drier, evacuate system and recharge	
	TEV seat leak (A gurgling or hissing sound is heard AT THE TEV during the off cycle, if this is the cause.) NOT APPLICABLE TO BLEED PORT VALVES.	Replace the TEV	
	Oversized TEV	Install correct TEV	
	Incorrect sensing bulb location	Install bulb with two mounting straps, in 2:00 or 4:00 position on suction line, with insulation	
	Low superheat adjustment (only applicable to TEV with adjustable superheat setting)	Turn superheat adjustment clockwise	
	Incorrectly installed, or restricted external equalizer line	Remove restriction, or relocate external equalizer	
Compressor flood back upon start up	Refrigerant drainage from flooded evaporator	Install trap riser to the top of the evaporator coil	
	Compressor in cold location	Install crankcase heater on compressor	
	Any of the causes listed under Symptoms of Problem #2	Any of the solutions listed under Solutions of Problem #2	

THERMOSTATIC EXPANSION VALVES

SYMPTOMS	POSSIBLE CAUSE	CHECK OR REMEDIES
Superheat is low to normal with low suction pressure	Unequal evaporator circuit loading	Ensure air flow is equally distributed through evaporator
		Ensure proper piston is inserted into RCBA or RCHA evaporator coil distributor
	Low load or airflow entering evaporator coil	Check for blocked distributor tubes
		Ensure blower is moving proper air CFM [L/s]
	Expansion valve is oversized	Remove/Correct any air flow restriction
		Install correct TEV
Superheat and suction pressure fluctuate (valve is hunting)	Sensing bulb is affected by liquid refrigerant or refrigerant oil flowing through suction line	Relocate sensing bulb in another position around the circumference of the suction line
	Unequal refrigerant flow through evaporator circuits	Ensure proper distributor piston is inserted in RCBA or RCHA coil
		Ensure sensing bulb is located properly
	Improper superheat adjustment (only possible with TEV having superheat adjustment)	Check for blocked distributor tubes
		Replace TEV or adjust superheat
	Moisture freezing and partially blocking TEV	Recover refrigerant, change filter-drier, evacuate system and recharge
	External equalizer line not connected or line plugged	Connect equalizer line in proper location, or remove any blockage
Valve does not regulate at all	Sensing bulb lost its operating charge	Replace TEV
	Valve body damaged during soldering or by improper installation	Replace TEV

IMPORTANT: SHIPPING STRAP REMOVAL

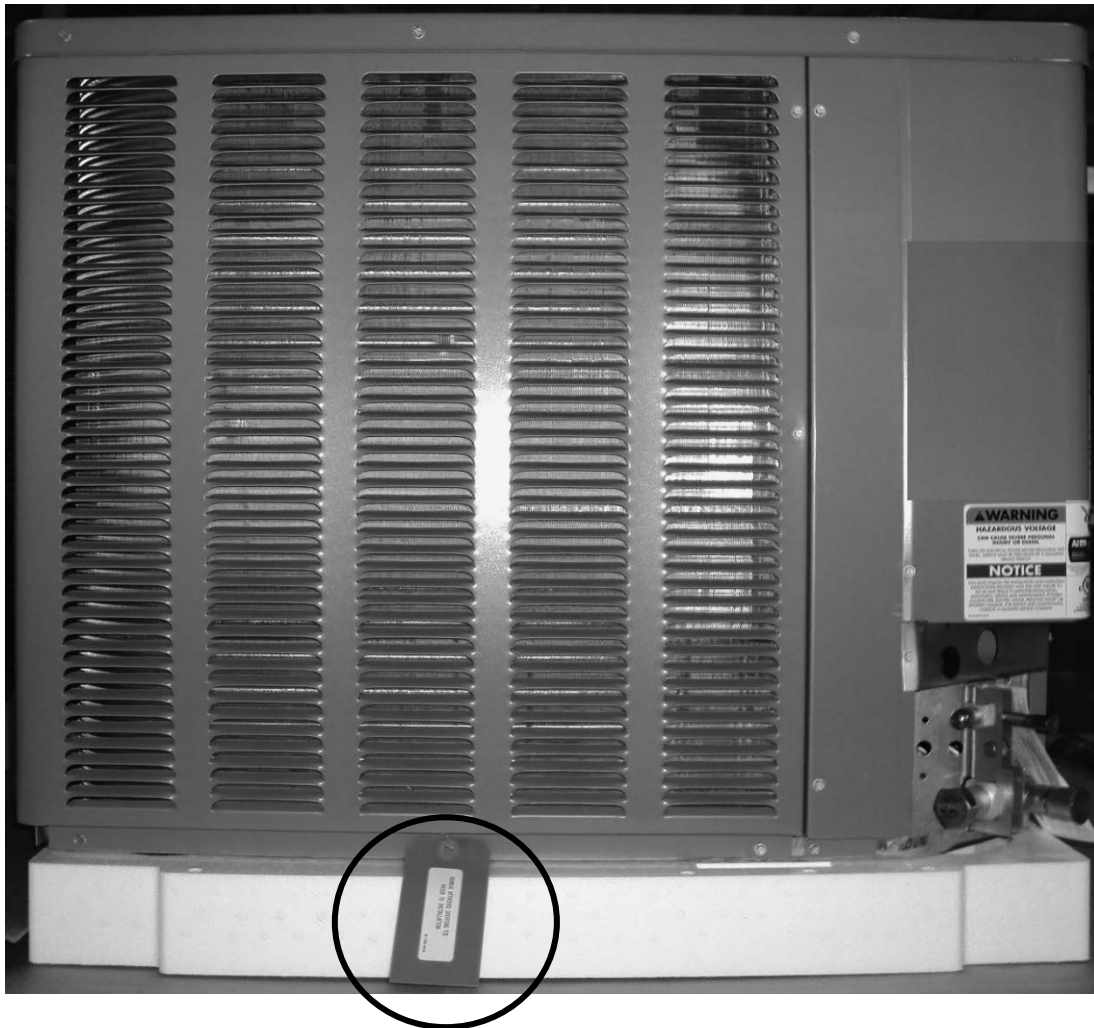

Notice: Failure to remove strap prior to operation could result in increased internal tubing stress. Plastic strap can be cut off from the exterior of the unit and left inside of the unit.

16.0 WIRING DIAGRAMS

16.1 ENHANCED DEFROST CONTROL - PSC MOTOR
FIGURE 5

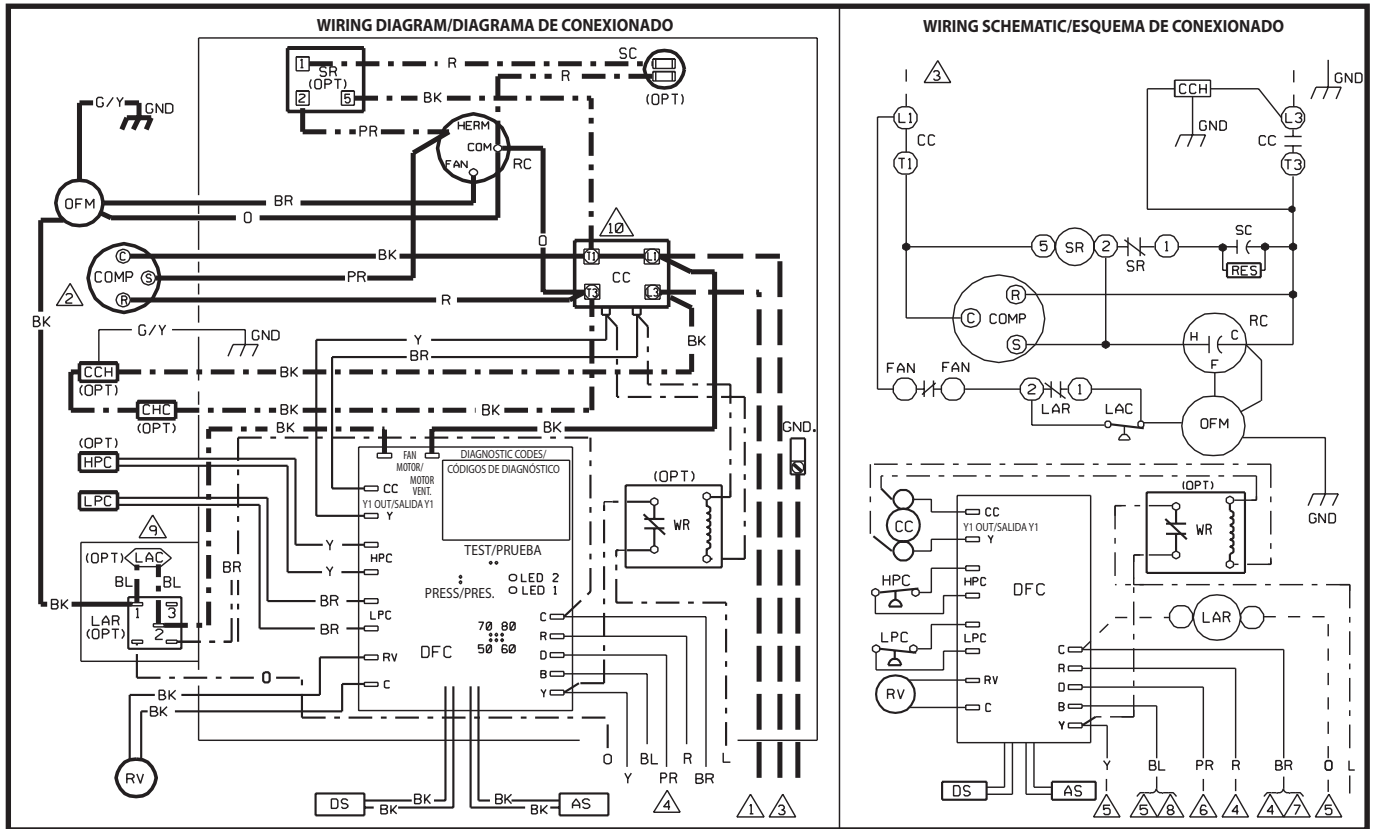

COMPONENT CODE/ CÓDIGO DE COMPONENTES	NOTES/NOTAS:
AS AMBIENT SENSOR/SENSOR AMBIENTAL	<ol style="list-style-type: none"> CONNECTORS SUITABLE FOR USE WITH COPPER CONDUCTORS ONLY./CONECTORES APTOS PARA UTILIZAR CON CONDUCTORES DE COBRE ÚNICAMENTE. COMPRESSOR MOTOR THERMALLY PROTECTED AND ALL 3 PHASE ARE PROTECTED UNDER PRIMARY SINGLE PHASE CONDITIONS./MOTOR DEL COMPRESOR CON PROTECCIÓN TÉRMICA, Y LAS 3 FASES PROTEGIDAS EN CONDICIONES MONOFÁSICAS DE PRIMARIO. CONNECT FIELD WIRING IN GROUNDED RAIN-TIGHT CONDUIT TO 60 HERTZ FUSE DISCONNECT, VOLTAGE AND PHASE PER RATING PLATE./HAGA EL CONEXIONADO DE CAMPO EN UN CONDUCTO A PRUEBA DE LLUVIA Y CONECTADO A TIERRA A LA ALIMENTACION DE 60 HERTZ, CON DESCONECTOR POR FUSIBLE, TENSION Y CANTIDAD DE FASES SEGUN LA PLACA DE CARACTERISTICAS. LOW VOLTAGE CIRCUIT TO BE N.E.C. CLASS 2 WITH A CLASS 2 TRANSFORMER 24 VOLT, 60 HERTZ./EL CIRCUITO DE BAJA TENSION SERA CONFORME A LA CLASE 2 DE N.E.C. CON UN TRANSFORMADOR DE 24 VOLTS, 60 HERTZ, DE CLASE 2. TO THERMOSTAT SUB-BASE. REFER TO SYSTEM SCHEMATICS OR SCHEMATICS ON INDOOR SECTION FOR LOW VOLTAGE CONTROL WIRING./A LA SUB-BASE DE TERMOSTATO POR EL CONEXIONADO DEL CONTROL DE BAJA TENSION. CONSULTE EL DIAGRAMA DEL SISTEMA O EL DIAGRAMA DE LA SECCION INTERIOR. THIS WIRE IS USED TO TURN ON STRIP HEAT DURING DEFROST. OMIT CONNECTION FOR MOST ECONOMIC OPERATION./ESTE CABLE SE UTILIZA PARA ENCENDER EL CALENTADOR DE TIRA DURANTE LA DESCONGELACION. OMITA LA CONEXION PARA QUE EL FUNCIONAMIENTO SEA MAS ECONOMICO. TO HEAT PUMP MONITOR 2.5 VA. MAX. WHEN USED./AL MONITOR DE LA BOMBA DE CALOR, 2.5 VA MAX., SI SE USA. THIS COMPONENT IS ENERGIZED IN HEATING MODE./ESTE COMPONENTE ESTÁ ENERGIZADO EN EL MODO DE CALENTAMIENTO. IF LAC/LAR IS NOT USED, CONNECT BLACK WIRE FROM OFM TO OFC FAN MOTOR./SI NO SE UTILIZA LAC/LAR, CONECTE EL CABLE NEGRO DEL OFM A FAN MOTOR DEL DFC. BLACK WIRE FROM SR (5) TO CC (T1) DELETED WHEN PTCR IS USED./EL CABLE NEGRO DEL SR (5) AL CC (T1) SE ELIMINA CUANDO SE UTILIZA EL TERMISTOR DE ARRANQUE (PTCR).
CC COMPRESSOR CONTACTOR/CONTACTOR DE COMPRESOR	
CCH CRANKCASE HEATER/CALENTADOR DEL CÁRTER	
CHC CRANKCASE HEATER CONTROL/CONTROL DEL CALENTADOR DEL CÁRTER	
COMP COMPRESSOR/COMPRESOR	
DFC DEFROST CONTROL/CONTROL DEL DESCONGELACION	
DS DEFROST COIL SENSOR/SENSOR DEL SERPENTIN DE DESCONGELACION	
GND GROUND, CHASSIS/TIERRA, CHASIS	
HPC HIGH PRES. CUT-OUT CONTROL/CONTROL DE CORTE POR ALTA PRESION	
LAC LOW AMBIENT COOLING CONTROL/CONTROL DE ENFRIAMIENTO, BAJA TEMP. AMBIENTE	
LAR LOW AMBIENT RELAY/RELE, BAJA TEMP. AMBIENTE	
LPC LOW PRESSURE CUT OUT CONTROL/CONTROL DE CORTE POR BAJA PRESION	
OFM OUTDOOR FAN MOTOR/MOTOR VENTILADOR EXTERIOR	
OPT OPTIONAL/OPCIONAL	
RC RUN CAPACITOR/CAPACITOR DE MARCHA	
RV REVERSING VALVE/VÁLVULA DE INVERSION	
SC START CAPACITOR/CAPACITOR DE ARRANQUE	
SR START RELAY/RELE DE ARRANQUE	
WR WARNING RELAY/RELE DE ALARMA	
WIRING INFORMATION/ INFORMACIÓN SOBRE CONEXIONADO	WIRE COLOR CODE/ CÓDIGO DE COLORES DE CABLES
LINE VOLTAGE/TENSION DE LINEA -FACTORY STANDARD/-ESTANDAR DE FABRICA -FACTORY OPTION/-OPCION DE FABRICA -FIELD INSTALLED/-INSTALADO EN EL SITIO LOW VOLTAGE/BAJA TENSION -FACTORY STANDARD/-ESTANDAR DE FABRICA -FACTORY OPTION/-OPCION DE FABRICA -FIELD INSTALLED/-INSTALADO EN EL SITIO REPLACEMENT WIRE/CABLE DE REEMPLAZO -MUST BE THE SAME SIZE AND TYPE OF INSULATION AS ORIGINAL (105°C MIN.)/-DEBE SER DEL MISMO CALIBRE Y TIPO DE AISLAMIENTO QUE EL ORIGINAL (105°C MIN.) WARNING/ADVERTENCIA -CABINET MUST BE PERMANENTLY GROUNDED AND CONFORM TO I.E.C., N.E.C., C.E.C. AND LOCAL CODES AS APPLICABLE./-EL GABINETE DEBE ESTAR CONECTADO A TIERRA EN FORMA PERMANENTE Y CUMPLIR CON LAS NORMAS DE I.E.C., N.E.C., C.E.C. Y LOS CODIGOS LOCALES QUE SEAN APLICABLES.	BK ___ BLACK/NEGRO BR ___ BROWN/MARRON BL ___ BLUE/AZUL G ___ GREEN/VERDE GY ___ GRAY/GRIS O ___ ORANGE/NARANJA PR ___ PURPLE/PURPURA R ___ RED/ROJO W ___ WHITE/BLANCO Y ___ YELLOW/AMARILLO
WIRING DIAGRAM/DIAGRAMA DE CONEXIONADO	REMOTE HEAT PUMP/BOMBA DE CALOR REMOTA SINGLE PHASE WITH PSC/ MONOFÁSICA CON CAPACITOR PERMANENTE (PSC) DEMAND DEFROST CONTROL/ CONTROL DE DESCONGELACION POR DEMANDA
DR. BY MGR	APP. BY DATE 1-11-09 DWG. NO. 90-101229-23 REV 04

16.2 ENHANCED DEFROST CONTROL - ECM MOTOR
FIGURE 6

