

STANDARD CONSTRUCTION
FRAME:

14 GAUGE ASTM A-653 HOT-DIPPED
GALVANIZED STEEL SHEET

TUBING:

16 GAUGE HOT-DIPPED GALVANIZED STEEL TUBE

OPTIONS:

CUSTOM SIZES AVAILABLE

STANDARD SIZES:

WIDTH (W)	HEIGHT (H)	DEPTH (D)	BOX QTY
14 - 24"	18"	22"	1
14" - 24"	24"	22"	1
17" - 27"	18"	22"	1
17" - 27"	24"	22"	1

FEATURES

GALVANIZED STEEL PROVIDES EXCELLENT
CORROSION RESISTANCE AND LONGEVITY.

BUILT-IN FILTER RACK ACCOMMODATES STANDARD 1"
FILTERS.

1/8" X 3/8" RUBBER STRIPS INCLUDED TO MINIMIZE
VIBRATION.

1" PLASTIC CAPS ON UPPER AND LOWER LEG
OPENINGS.

UNIVERSAL DEPTH TO FIT MOST AIR HANDLER UNITS.

N: WIDTH ADJUSTABLE FROM 14" - 24"

W: WIDTH ADJUSTABLE FROM 17" - 27"

AVAILABLE IN PALLET QUANTITY (25
UNITS/PALLET).

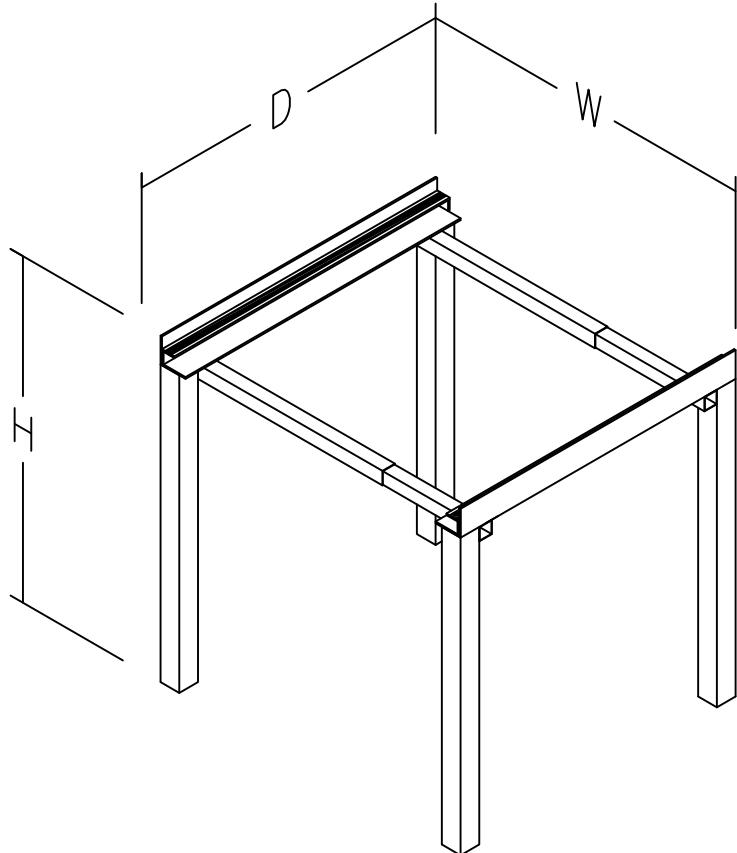

JOB NAME:
LOCATION:
ARCHITECT:
ENGINEER:
CONTRACTOR:
CONTACT MIAMI TECH INC. FOR ADDITIONAL INFORMATION OR WITH SPECIAL REQUIREMENTS.
3611 NW 74TH ST MIAMI, FL 33147 PHONE: 305-693-7054 FAX: 305-693-6152
WEB: WWW.MIAMITECH.COM EMAIL: SALES@MIAMITECH.COM

HEB

AIR HANDLER STAND
PRODUCT SPECIFICATIONS

NOTE: ALL DRAWINGS SUBJECT TO CHANGE WITHOUT PRIOR NOTICE.