



CORR/GUARD DOUBLE WALL INSTALLATION INSTRUCTIONS

CG AL29-4C Stainless Steel - Pressure Rated Venting System
CGV 444 Stainless Steel - Pressure Rated Venting System

IMPORTANT: DO NOT INSTALL WITHOUT FIRST READING THESE INSTRUCTIONS VERY CAREFULLY.

Corr/Guard, manufactured by Metal-Fab, Inc. is a special stainless steel venting system for gas-fired appliances listed as Cat. II, III & IV or in Canada, Type BH Gas Venting Systems per ULC-636, with rated operating temperature of 550° F (287° C), and rated for positive pressure of 10" w.c. Metal-Fab, Inc. recommends the system be inspected once a year by a qualified service technician.

Examine all components for possible shipping damage before installation. Proper joint assembly is essential for a safe installation. Follow these instructions exactly as written. Check severe stress of joints upon completion of assembly. This venting system must be free to expand and contract. Check for unrestricted movement through walls, ceilings and roof penetrations. Different manufacturers have different joint systems and adhesives. Do not mix pipe, fittings or joining methods from different manufacturers.

Corr/Guard Double Wall vent is designated as Model CG or CGV and may be used to vent any appliance where AL29-4C® or 444 vent material is specified in the appliance manufacturers installation instructions and performance criteria is within the limitations in these instructions.

Venting system design may be limited by appliance performance. Consult appliance installation instructions to determine proper sizing and limitations such as maximum horizontal length, maximum height, maximum number of elbows or offsets, connecting two or more appliances to a common venting system, and other limitations, which may affect design and installation.

The authority having jurisdiction (such as gas inspection authority, municipal building department, fire department, fire prevention bureau, etc.) should be consulted before installation to determine the need to obtain a permit. **NOTE: The Corr/Guard venting system is rated for 10" w.c. based on tests requiring an internal pressure 2-1/2 times the rated pressure.**

GENERAL

Corr/Guard is to be installed in accordance with these installation instructions and those of the appliance manufacturer. For conditions and applicable restrictions not specifically mentioned herein, contact building or fire officials having jurisdiction in your area.

- Planning the layout of the vent system before installation may eliminate unforeseen problems.
- Consider horizontal runs, elbows, system height, clearances, firestopping, and terminations.
- Corr/Guard Model CG or CGV double wall vent may be used with Model CGSW or CGVSW single wall vent within the same vent system.
- Any portion of a horizontally installed vent shall have a slope (upwards for Cat. II, III or IV appliances or downwards for Cat. III or IV appliances) not less than 1/4 inch (6.4 mm) every 12 inches (305 mm) to prevent collection of condensate at any location in the assembly.
- Means shall be provided for drainage of condensate. Due to ice build up and blockage, it is required that the proper slope be employed when the vent is installed in a horizontal installation.
- Consult the appliance installation instructions for further details regarding the installation of condensate drain fittings.
- Identify the condensate discharge point and determine routing of condensate drain piping.
- **WARNING: Do not place or install insulation in any required clearance spaces surrounding the venting system.**

A venting system that exits through a side wall shall:

1. Terminate not less than 12 inches (305 mm) above the ground.
2. Be located above the snow line in geographical areas where snow accumulates.
3. Not be located in traffic areas such as walkways unless the venting system is at least 7 feet (2.1 m) above the ground.

When appliance incorporates a combustion air inlet system, the venting system shall terminate:

1. 6 feet (1.8m) or more from the combustion air intake of any appliance.
2. More than 3 feet (0.9m) from any other building opening, gas utility meter, service regulator or the like.
3. Less distance if specified in the appliance's installation instructions.

The venting system shall terminate in accordance with local building code requirements and National Codes: USA-NFPA 54 ANSI - Z223.1 or NFPA 211. In Canada - CAN / CGA-B149.1, Natural Gas Installation Code, or CAN / CGA-149.2 Propane Installation Code, as applicable.

TABLE 1

Rated Operating Temperatures		Minimum Clearance Enclosed		Minimum Clearance Unenclosed	
Diameter	Temp.	Horizontal	Vertical	Horizontal	Vertical
3" Only	330°F 177°C	0" 0mm	0" 0mm	0" 0mm	0" 0mm
	400°F 204°C	6" 25mm	0" 0mm	1" 25mm	0" 0mm
3", 4" & 5"	480°F 249°C	6" 25mm	1" 25mm	1" 25mm	1" 25mm
	550°F 288°C	N/A	N/A	1" 25mm	1" 25mm
4" & 5" Only	300°F 149°C	3" 76mm	1" 25mm	1" 25mm	1" 25mm

VENT CLEARANCES

Framing of openings shall provide proper clearances, support, and the installation of firestop assemblies where applicable. (See TABLE 2) Examples of acceptable methods of installation which demonstrate minimum clearances and supporting means are show below:

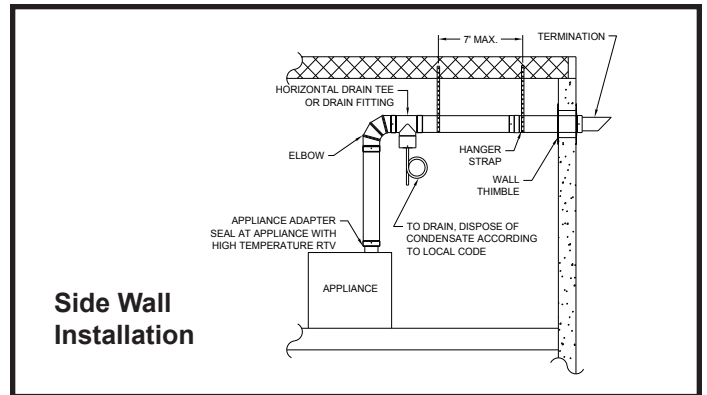

For venting systems that extend through any zone above that on which the connected appliance is located (except for one and two family dwellings), the vent system shall be enclosed with an enclosure having a fire resistance rating equal to or greater than that of the floor or roof assemblies through which it passes.

When installed on Cat. II, III or IV appliances, Corr/Guard shall not be routed into, through or within any other vent, existing masonry or factory built vent. **Exception: An abandoned masonry vent may be used to route the venting system if no other appliance is vented into the same masonry vent and the venting system is terminated beyond the terminus of the masonry vent.**

To limit condensation and provide additional protection, it is recommended that vents exterior to the structure and below the roofline be enclosed.

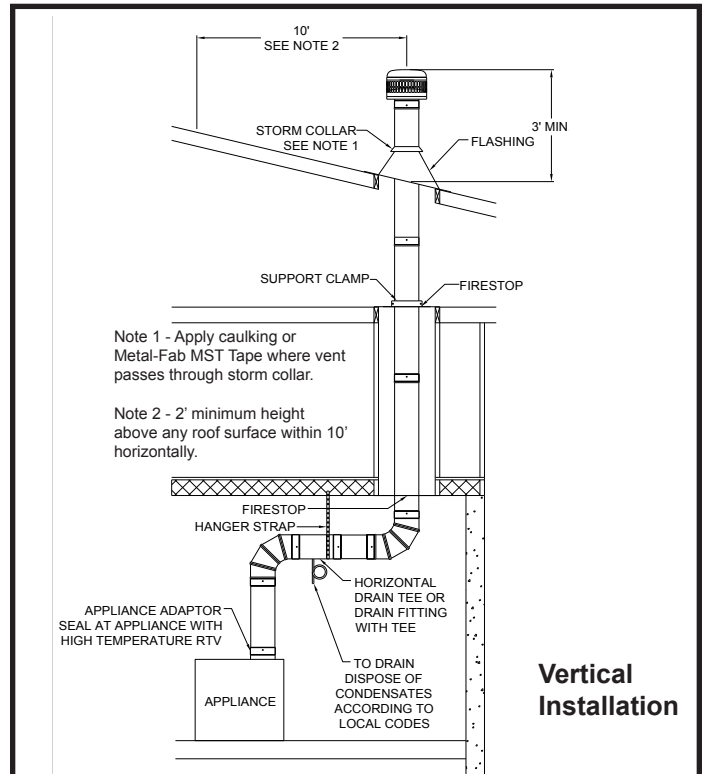

TABLE 2 - Support Limits and Framing Dimensions (Vertical)

Support Method	Pipe Size	Maximum Height	Frame Dimensions (Inside Dimensions)
Plate Supports, Firestops & Roof Supports	3"	30' (9m)	7" x 7" (minimum)
	4"	30' (9m)	8" x 8" (minimum)
	5"	30' (9m)	9" x 9" (minimum)
Wall Supports	3"	30' (9m)	Not Applicable
	4"	30' (9m)	
	5"	30' (9m)	

JOINT ASSEMBLY

Connections between vent and fittings are male/female type. The inner duct is sealed with an integral seal gasket and the joint is mechanically secured via the overlapping outer wall of the double wall pipe.

Joints are assembled per the following steps:

1. Before assembly, observe that the seal gasket is located within the female inner pipe joint. Locate next pipe or fitting with male inner pipe joint and insert to begin engagement of inner pipe joint.
2. As the joint further engages, align the male and female ends of the outer wall of each pipe so that they begin to engage as the pipes are further pushed together.
3. Pipe joint is fully engaged when the female end of the outer pipe comes in contact (or is at least within 1/16th inch) to the base of bead on the male end of the adjoining vent pipe.
4. When possible look within the pipe assembly to verify that no sign of seal gasket is showing. Complete the joint assembly by securing the joint using #8 x 1/2" sheet metal screws (3 per joint) at each pre-punched hole on the female end of each joint.

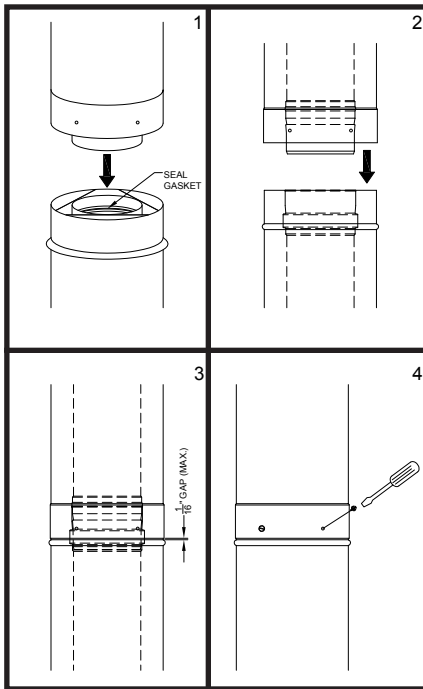

Joint Assembly

WARNING: Sheet metal screws are for outer wall only. Never use screws, rivets or other fasteners to penetrate the inner pipe wall.

INSTALLATION

- Install roof penetrations as shown in this figure, maintaining minimum clearances for enclosed or unenclosed spaces. (See TABLE 1)
- A cap is attached to the top section using three #8x1/2" sheet metal screws.
- Stack height above the roofline should not exceed 5' (1.5 m) unless supported by guy wires or rigid support bracing.

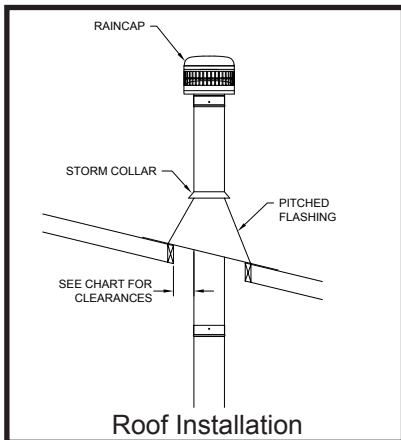

Roof Installation

Support horizontal runs adequately to maintain proper slope. If the horizontal section of the vent exceeds 7 feet in length, install hanger straps (plumber's tape, wall hangers, or other non-combustible material) every 7 feet to support the connector from ceiling joists or other solid structures capable of supporting the vent.

NOTE: Do not rivet or screw the straps to the vent or otherwise puncture the vent wall. Wrap an extra loop of strap around the vent to hold it in position.

Vents must not sag or dip providing areas for condensate to collect.

Vertical supports are to be used after each transition to vertical and/or after every 30 feet of vertical vent. Vertical support is required after every offset elbow to prevent vertical loading on offsets.

TABLE 3 - Support Limits and Framing Dimensions (Horizontal)

Support Method	Pipe Size	Distance Between Supports	Frame Dimensions (Inside Dimensions)
Wall Penetration	3"	7' (2.1m)	8" x 8" (minimum)
	4"	7' (2.1m)	9" x 9" (minimum)
	5"	7' (2.1m)	10" x 10" (minimum)
Horizontal Runs & Between Elbows	3"	7' (2.1m)	Not Applicable
	4"	7' (2.1m)	
	5"	7' (2.1m)	

VARIABLE LENGTH

For installations that require non-standard vent lengths, Corr/Guard Variable Length vent sections may be used. The vent section consists of a telescoping inner conduit and outer casing. When installed, the VL vent section will add 5" to 20" in finished length to the venting system.

To install the VL vent section, first install the inner pipe section by connecting the male section to the adjoining Double Wall vent pipe. Insert male section until the bead of the joint stops at the edge of the female end of the Double Wall vent section.

Next, expand the length of the inner pipe to the necessary length and tighten the integral clamping band using a hex drive or screwdriver. Continue with the next section of Double Wall vent, making sure to fully join the inner pipe of the vent to the female end of the VL vent.

Once the vent system is completely assembled and supported, finish the VL vent assembly by installing the outer casing wall around the VL inner pipe section. Secure the casing by installing #8x1/2" sheet metal screws at pre-punched hole locations.

NOTE: The VL pipe casing may be cut to length if needed.

MAINTENANCE

The Corr/Guard vent system should be inspected at least annually for the presence of deposits or debris and any accumulation should be removed. The vent system should also be inspected at regular periods for signs of leakage of condensate or combustible products at any joint.

If the vent system incorporates a drain hose from either an inline fitting or from a drain tee, the hose must be inspected periodically to assure that water is in the trap loop. If a proper trap loop is not maintained, exhaust from the connected appliances may accumulate in the building area.

IMPORTANT: The listing for this product is void if components other than those supplied as Listed Components by Metal-Fab, Inc. are used. All warranties, stated or implied, are void if this product and the appliances to which it is connected are not installed in accordance with their respective instructions and local code requirements.

