

LEAVE THIS BULLETIN ON THE JOB SITE FOR FUTURE REFERENCE

The HK2000 Fresh Air & Economizer Panel provides Economical, and Intelligent Control of Residential and Light Commercial Cooling Systems, using the included Dry Bulb Mode sensor, or an optional Enthalpy Control.

The HK2000 can control up to three (3) 24 vac dampers. Outside Air, Return Air, and Exhaust Air.

The HK2000 also provides an adjustable Time Based Fresh Air Cycling Schedule, to purge your home or office of stale air and odors. Using the HK2000 can cut your cooling bills and help to cure a sick home or building.

The HK2000 is suitable for all new construction and most retro-fit applications.

Contents

HK2000 Economizer Control Panel
Outside Air Temperature Sensor
Technical Bulletin TB-214
Mounting Hardware

Compatible HVAC Systems

Compatible with single stage conventional HVAC Systems. Electric air conditioning with Gas, Oil, Electric or Hydronic heating systems. Two stage systems can also be controlled.

Compatible Thermostats

Compatible with standard heat/cool mechanical or electronic thermostats that operate on 24vac. Also Battery operated or power robbing type thermostats that draw less than 25 ma of current.

INPUT VOLTAGE:

PANEL: 19-30VAC 60 Hz, Supplied via HVAC Equipment Transformer.

DAMPERS: 19-30VAC 60 Hz, 40-60VA Max. NEC Class 2.

CURRENT DRAW: Max 8VA @ 24VAC.

OVER-CURRENT PROTECTION:

PANEL: 4.0 amp or 96VA. Protected via UZC4.

DAMPERS: 2.5 amp or 60VA.

Bypass Switch

The on-board Bypass Switch allows the user to shutdown the HK2000, and operate the HVAC system in the standard mode. All economy and fresh air operations are disabled.

TB-214 P/N 090375A0214 REV. G

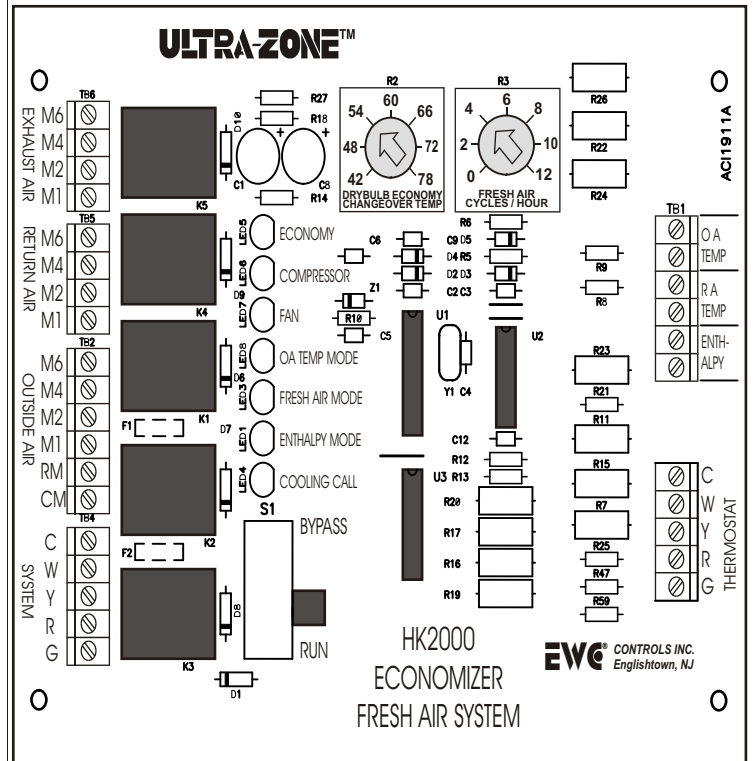

HK2000 Economizer & Fresh Air Control System

Thermal Circuit Breakers

The HK2000 has 2 thermal circuit breakers that protect the panel from shorts in the thermostat and damper field wiring.

CAUTION: When the circuit breaker is tripped it will get quite hot. To reset the breaker, remove the 24vac power. Locate and repair the short. Then restore the power. See Page 9

Status LED's

Seven (7) LED's are provided on the HK2000 to provide visual indication of the System Mode and Status. See Page 7 for details.

Operating Power

TEMPERATURE: -20° to 160°F (-29° to 71°C)
HUMIDITY: 0% - 95% RH Non-Condensing.

Support

EWC Controls provides superior Technical Support.
 1-800-446-3110

Copyright© EWC Controls 2003-2008 All Rights Reserved

Built-In Timer Settings

The panel has built-in timers that insure safe & reliable operation.

- * **Short Cycle Timer: 1 minute, fixed.**
- * **Economy Termination Timer: 15 minutes, fixed.**
- * **Fresh AirTimer: 0 -12 cycles per hour, Adjustable**

SEE PAGE 8

Short Cycle Timer-Fixed

When the thermostat is satisfied, the HK2000 will prevent compressor from energizing for a 1 minute delay. Heating demands are not interfered with or delayed at all.

Economy Termination Timer-Fixed

When the HK2000 has made the decision to "Economize," and all dampers are energized to the "Outside Air Mode." Mechanical Cooling is locked out.

A 15 minute timer starts, and if the cooling call is not satisfied in that time, it will terminate the economy operation. The HK2000 will energize the mechanical cooling to satisfy the building load. **Dry Bulb Mode Only.**

Fresh Air Timer

The adjustable fresh air timer can be set to automatically activate the controlled dampers to the "Fresh Air Mode" on a regular schedule. A setting of "0" is OFF. A setting of "12" is continuous fresh air.

Example: A single hour is divided into 5 minute increments of fresh air. The installer has chosen a setting of 4 cycles per hour, which results in a total of 20 minutes of fresh air every hour. The HK2000 will activate the dampers into the Fresh Air Mode for 5 minutes every quarter hour.

This helps to reduce the possibility of complaints due to the introduction of cold or hot air into the building. It also minimizes the load on the HVAC system. It can help satisfy Fresh Air Code Requirements.

Caution: The Fresh Air Timer operates regardless of the outside air temperature. Take proper freeze protection precautions. Do not set the Fresh Air Timer for continuous outside air during extreme winter or summer Conditions.

NOTE: A 5 minute delay occurs when the Fresh Air Cycle Setting is changed.

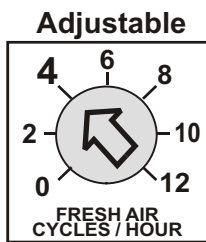

Refer to the Fresh Air Cycle Chart on page 8

Outside Air Sensor

The HK2000 includes a reliable 10K Thermistor/Sensor. The sensor must be mounted outdoors, and wired back to the panel. It provides the processor a means of reading *the outside dry bulb temperature*. Used with OA Temp Mode and Mechanical Cooling Assistance.

Optional Return Air Sensor

Required for Mechanical Assisted Cooling Only

An *Optional Return Air Sensor* can be connected to the HK2000. The sensor must be mounted in the Return air duct, and wired back to the panel. It provides the processor a means of reading *the return dry bulb temperature*. Used with Mechanical Cooling Assistance.

Sensor Mounting

Follow the directions included with each sensor. Avoid direct sunlight when mounting the outside air sensor. Do not run sensor wires on top of or inside conduit that carry high voltage conductors. Mount the return air sensor in a suitable location in the return air duct, which allows the sensor to read only the air temperature returning from the occupied space.

Damper Selection

Never close the return air damper when the outside air duct is undersized or closed.

Select up to three (3) dampers to control: **Outside Air, Return Air, Exhaust Air.** Based on your particular application you may only need to control the outside air damper. You can use **24vac Actuated; Multi-Position, Spring Safe, Patented Optical, or Min/Max Adjustable Dampers.**

Control two or three dampers and use Min/Max or Multi-position dampers when mixing of the air is desired during all modes of operation. Your actual system configuration will be determined by the existing and /or new duct work.

Wiring and System Operations

The HK2000 connects easily to the HVAC System. It wires in series with your new or existing control circuitry and receives commands from the thermostat, or zone control system. Heating commands are always honored immediately. Cooling demands are honored by using cool outside air or mechanical cooling. Fresh Air Cycles operate independent of heating or cooling operations.

INSTALLATION INSTRUCTIONS

WARNING: THESE PANELS ARE DESIGNED FOR USE WITH 24VAC. DO NOT USE OTHER VOLTAGES! USE CAUTION TO AVOID ELECTRIC SHOCK OR EQUIPMENT DAMAGE. ALL WIRING SHOULD BE DONE TO LOCAL AND NATIONAL CODES AND ORDINANCES. USE COLOR-CODED, MULTI-CONDUCTOR WIRE. WIRE NUMBER TO NUMBER OR LETTER TO LETTER ON EACH CONTROL.

FRESH AIR / ECONOMIZER WIRING DIAGRAM

Model HK2000 **ULTRAZONE™** Control Panel

DRY BULB CONTROL MODE

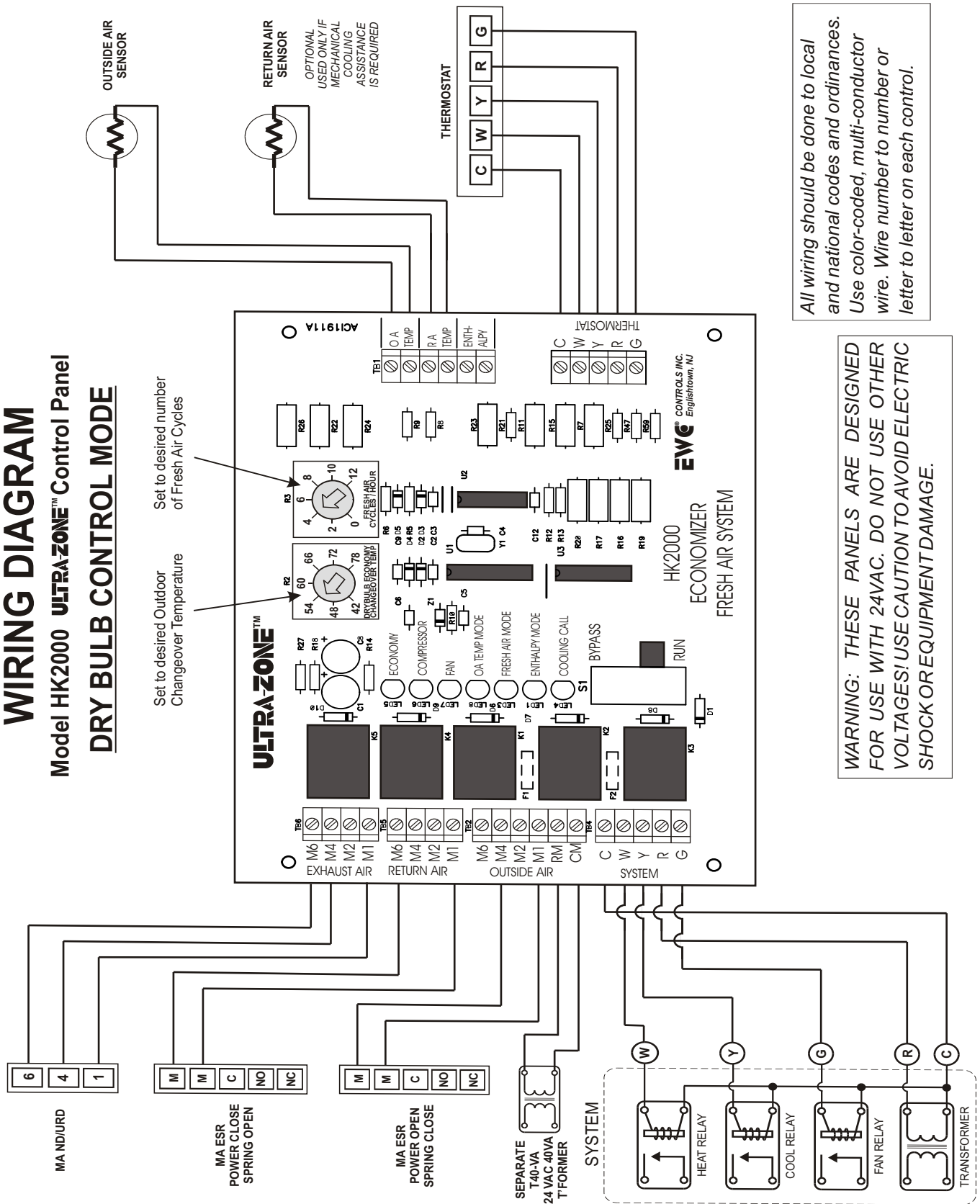

All wiring should be done to local and national codes and ordinances. Use color-coded, multi-conductor wire. Wire number to number or letter to letter on each control.

WARNING: THESE PANELS ARE DESIGNED FOR USE WITH 24VAC. DO NOT USE OTHER VOLTAGES! USE CAUTION TO AVOID ELECTRIC SHOCK OR EQUIPMENT DAMAGE.

Sequence of Operation for Economy

Dry Bulb Mode

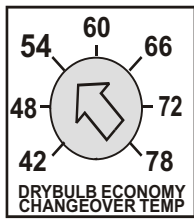

Dry Bulb Mode is locked out below 40 and above 80 degrees F.

Mechanical Cooling Assistance

Return and Outside Air Sensor must be connected for this feature to operate.

This feature will not function if the temperature is below 40 or above 80 degrees F.

This feature requires the use of the Return Air Sensor.

The HK2000 monitors the outside air sensor to determine if the actual outdoor temperature is lower than the Dry Bulb Economy Changeover setting on the board. When the outdoor temperature is lower than the setting on the board, the "OA Temp Mode" LED on the panel will illuminate. The HK2000 will attempt to satisfy cooling demands with outside air. If the outdoor temperature is higher than the setting on the board, the HK2000 will activate mechanical cooling instead, to satisfy the cooling demands.

When the HK2000 detects a demand for cooling from the thermostat, and the Outside Air Mode LED is illuminated, it will activate the indoor fan, lock out the mechanical cooling, and energize all dampers to the Outside Air Mode. **(Free Cooling)**

At the same time it also starts the economy termination. If the cooling demand does not satisfy by the end of 15 minutes, The HK2000 will terminate the economy operation, and energize mechanical cooling to satisfy the cooling demands. All dampers default to the Return Air Mode, unless a Fresh Air Cycle or Mechanical Cooling Assistance occurs at the same time.

Only during mechanical cooling operations. The HK2000 will monitor return air temperature, and compare it to outside air temperature. If the outside air temperature is seven (7) degrees lower than the return air temperature, it will energize the dampers to the Outside Air Mode keeping the compressor energized. The mechanical assistance will remain energized until the Delta T, between Outdoor and Return air has drop to 3 degrees F or less. The Mixing of these two air sources can reduce the load on the mechanical cooling system and satisfy the cooling demand faster. That means real energy savings is achieved and extends the life of your compressor. **DO NOT install or completely close off a return air damper when operating in this mode.**

Sequence of Operation for Economy

Enthalpy or External Device Mode

If the Installer uses an Optional Enthalpy Control, **The HK2000 will operate based upon the action of the Enthalpy Control.** When the Enthalpy Control *Closes* it's contacts, the "Enthalpy Mode" LED on the panel will illuminate.

The HK2000 will attempt to satisfy cooling demands with outside air.

If the Enthalpy control *Opens* it's contacts, the HK2000 will activate mechanical cooling to satisfy the cooling demands.

When the HK2000 detects a demand for cooling from the thermostat, and the Enthalpy Mode LED is illuminated, it will activate the indoor fan, lock out mechanical cooling, and energize all dampers to the Outside Air Mode. **(Free Cooling)**

If the HK2000 detects that the Enthalpy control has opened it's contacts, The HK2000 will terminate economy operation, and energize mechanical cooling to satisfy the cooling demand. All dampers default back to the Return Air Mode, unless a Fresh Air Cycle occurs at the same time.

NOTE: Follow the instructions when installing and setting up the Enthalpy control. It should be mounted on the outside air duct where it can sense the outdoor conditions, regardless of the position of the Outside Air damper.

NOTE: The Economy Termination Timer does not function when Enthalpy Mode has been set. Mechanical cooling is locked out until the Enthalpy control or other device has opened it's contacts.

NOTE: Other control devices can be connected to the Enthalpy input terminals such as:

- * Time Clock
- * Manual Switch
- * CO monitor/control

General Note:

*When the economy mode cycle has been terminated by the Timer or by the attached Enthalpy Control, mechanical cooling will be used until the end of that cooling cycle. The HK2000 will not attempt another Economy Mode until conditions are correct and the next cooling demand occurs.

INSTALLATION INSTRUCTIONS

WARNING: THESE PANELS ARE DESIGNED FOR USE WITH 24VAC. DO NOT USE OTHER VOLTAGES! USE CAUTION TO AVOID ELECTRIC SHOCK OR EQUIPMENT DAMAGE. ALL WIRING SHOULD BE DONE TO LOCAL AND NATIONAL CODES AND ORDINANCES. USE COLOR-CODED, MULTI-CONDUCTOR WIRE. WIRE NUMBER TO NUMBER OR LETTER TO LETTER ON EACH CONTROL.

FRESH AIR / ECONOMIZER WIRING DIAGRAM

Model HK2000 **ULTRA-ZONE™** Control Panel ENTHALPY CONTROL MODE

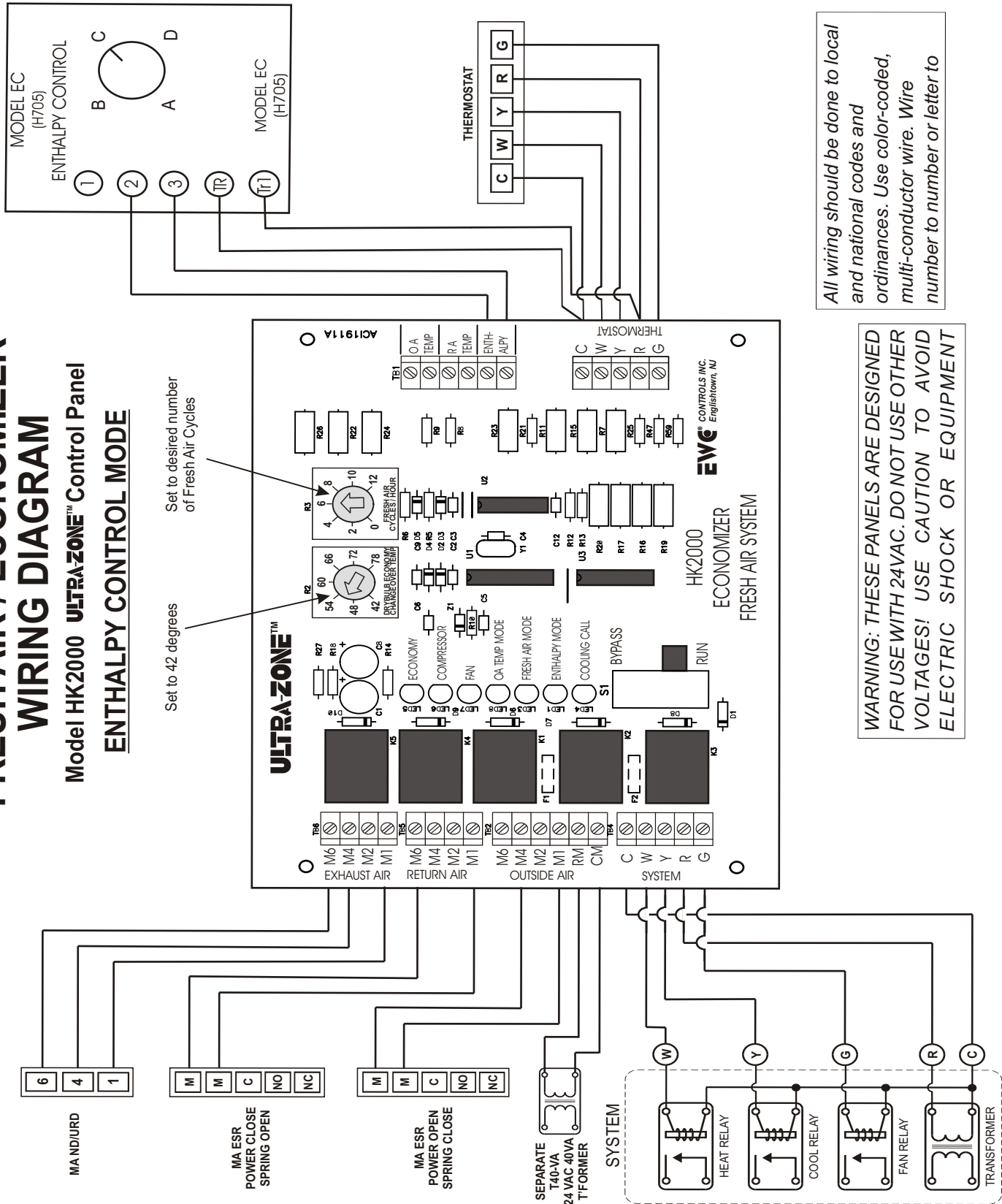

All wiring should be done to local and national codes and ordinances. Use color-coded, multi-conductor wire. Wire number to number or letter to letter on each control.

WARNING: THESE PANELS ARE DESIGNED FOR USE WITH 24VAC. DO NOT USE OTHER VOLTAGES! USE CAUTION TO AVOID ELECTRIC SHOCK OR EQUIPMENT DAMAGE.

24VAC Power Wiring

A single 24vac, 40va transformer can power up to three (3) 24vac dampers. More dampers can be controlled by using isolation relays and additional transformers.

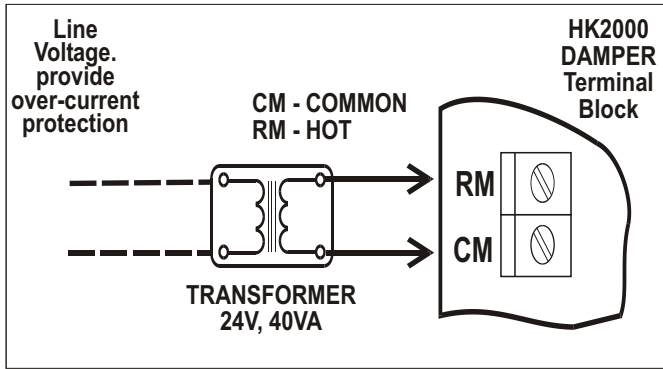

24vac Damper Power Wiring.

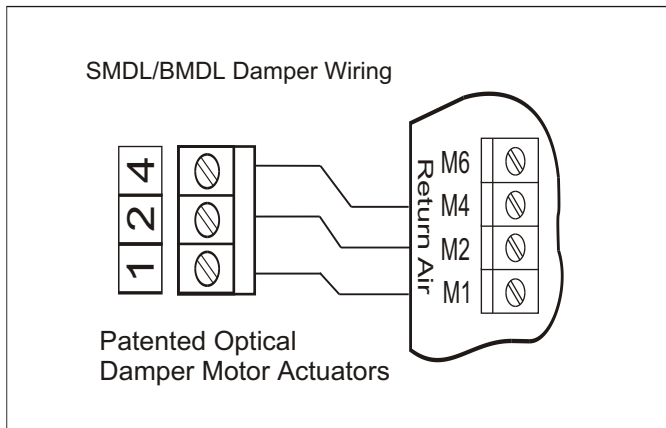

DAMPER MODE DEFINITIONS

RETURN Air Mode = Return Air Damper - OPEN
DEFAULT Outside Air Damper - CLOSED
 Exhaust Air Damper - CLOSED

OUTSIDE Air Mode = Return Air Damper - CLOSED
 Outside Air Damper - OPEN
 Exhaust Air Damper - OPEN

FRESH Air Mode = Return Air Damper - CLOSED
 Outside Air Damper - OPEN
 Exhaust Air Damper - OPEN

MECHANICAL

ASSISTANCE Mode = Return Air Damper - CLOSED
 Outside Air Damper - OPEN
 Exhaust Air Damper - OPEN

Warning: Your application may limit the dampers you can or want to control. **Do not** install a return air damper or completely close off a return air damper, when the outside air duct/damper is undersized or completely closed off.

Spring Return Motor Wiring

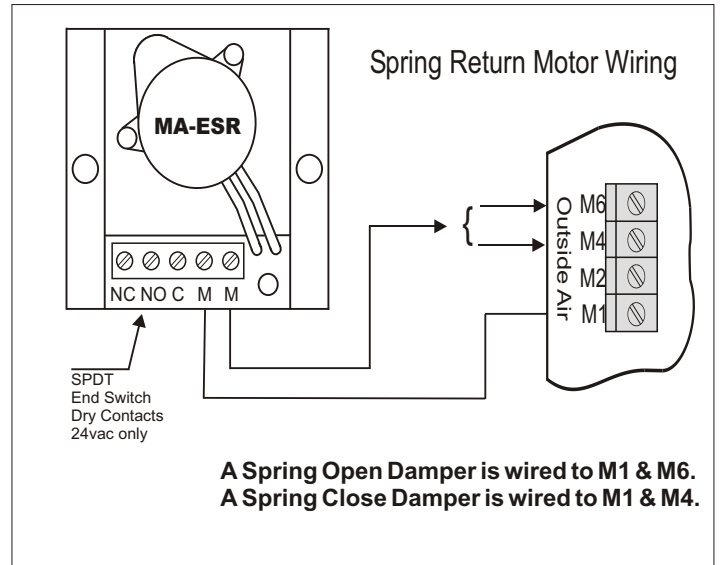

Motor Actuator Damper Wiring

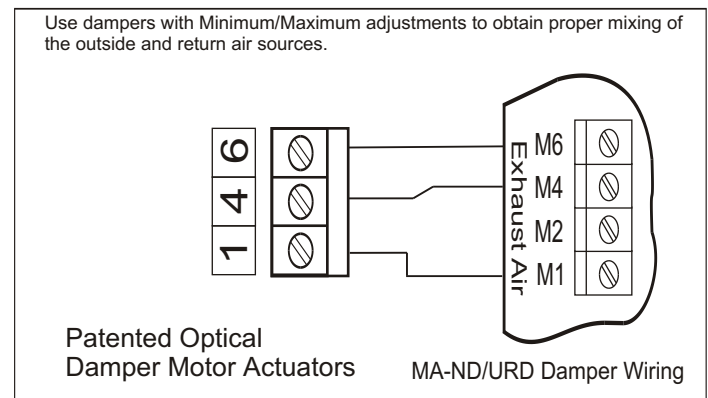

Patented Optical Damper Motor Actuators

MA-ND/URD Damper Wiring

DAMPER TERMINAL DESIGNATION & FUNCTION

Terminal M1 Common 24vac
 Terminal M2 Constant hot 24vac
 Terminal M4 24vac to open damper.
 Terminal M6 24vac to close damper.

DEFINITIONS

RAD = Return Air Damper
 OAD = Outside Air Damper
 EAD = Exhaust Air Damper

OAS = Outside Air Sensor
 RAS = Return Air Sensor
 EC = Enthalpy Control
 ED = External Device

HK2000 LED's

The HK2000 is equipped with 7 LED's which indicate system operation and status. Familiarize yourself with the LED's definitions, in order to quickly determine the system status and mode of operation.

(RED)	ECONOMY	Economy LED illuminates when panel has activated all dampers to the Outside Air Mode, Fresh Air Mode, Enthalpy Mode, or Mechanical Assistance Mode.
(RED)	COMPRESSOR	Compressor LED illuminates when panel has activated the Mechanical Cooling or Mechanical Cooling Assistance.
(RED)	FAN	Fan LED illuminates when the panel has activated the Indoor Fan Blower.
(GREEN)	OA TEMP MODE	Flashes in unison with Fresh Air & Enthalpy LED's to indicate System Status. Illuminates when Outside Air Temperature is suitable for Economy Operations.
(GREEN)	FRESH AIR MODE	Flashes in unison with Outside Air & Enthalpy LED's to indicate System Status. Illuminates when a scheduled Fresh Air Cycle is active.
(GREEN)	ENTHALPY MODE	Flashes in unison with the Outside Air & Fresh Air LED's to indicate System Status. Illuminates when the Enthalpy control or other external device has closed it's contacts.
(RED)	COOLING CALL	Cooling Call LED illuminates when the panel detects a cooling demand from the Thermostat.

NOTE: It is possible to observe both the Economy LED and the Compressor LED illuminated at the same time.

EXAMPLE 1: A call for cooling has occurred but outdoor conditions are not suitable to satisfy the demand, so the compressor is activated and the Compressor LED illuminates. The Fresh Air Cycle Schedule activates the dampers to the Fresh Air Mode to satisfy fresh air requirements, so the Economy LED will also illuminate.

EXAMPLE 2: A call for cooling has occurred but outdoor conditions are not suitable to satisfy the demand, so the compressor is activated and the Compressor LED illuminates. The Mechanical Assistance Feature activates the dampers to the Fresh Air Mode to assist the compressor, so the Economy LED will also illuminate.

A Return and Outdoor Air Sensor is required in order to utilize the Mechanical Cooling Assistance Feature. The Fresh Air Cycle Schedule operates independent of all other functions, and regardless of outside temperatures.

BASIC MODE LED INDICATIONS

	ECONOMY	COMPRESSOR	FAN	OA TEMP MODE	FRESH AIR MODE	ENTHALPY MODE	COOLING CALL
MECH. COOLING CALL	OFF	ON	ON	OFF	OFF	OFF	ON
MECH. ASSISTED COOLING	ON	ON	ON	OFF	OFF	OFF	ON
FRESH AIR MODE	ON	OFF	ON	OFF	ON	OFF	OFF
OUTSIDE AIR MODE	ON	OFF	ON	ON	OFF	OFF	ON
ENTHALPY MODE	ON	OFF	ON	OFF	OFF	ON	ON

FRESH AIR CYCLE CHART

Fresh Air Cycle/ Hour	1st Qtr Hr	2nd Qtr Hr	3rd Qtr Hr	4th Qtr Hr
F.A.C./hr=0				
F.A.C./hr=1	X			
F.A.C./hr=2	X		X	
F.A.C./hr=3	X	X		
F.A.C./hr=4	X	X	X	X
F.A.C./hr=5	X	X	X	X
F.A.C./hr=6	X	X	X	X
F.A.C./hr=7	X	X	X	X
F.A.C./hr=8	X	X	X	X
F.A.C./hr=9	X	X	X	X
F.A.C./hr=10	X	X	X	X
F.A.C./hr=11	X	X	X	X
F.A.C./hr=12	X	X	X	X

Adjustable

Fresh Air
Timer

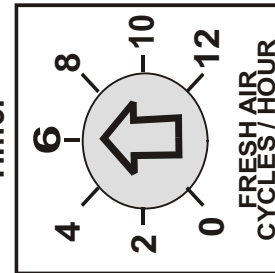

The Adjustable Fresh Air Timer can be set to automatically activate the controlled dampers to the "Fresh Air Mode" on a regular schedule. A setting of "0" is OFF. A setting of "12" is continuous fresh air.

Example: A single hour is divided into Five (5) minute increments of fresh air. The installer has chosen a setting of 6 cycles per hour, which results in a total of 30 minutes of fresh air every hour. The HK2000 will activate the dampers into the Fresh Air Mode for 10 minutes the 1st qtr. Hour, 5 minutes the 2nd qtr. Hour, 10 minutes the 3rd qtr. Hour, and 5 minutes the 4th qtr. Hour.

This helps to reduce the possibility of complaints due to the introduction of cold or hot air into the building. It also minimizes the load on the HVAC system. It satisfies fresh air code requirements.

Caution: The Fresh Air Timer operates regardless of the outside air temperature. Take proper freeze protection precautions. Do not set the Fresh Air Timer for continuous outside air during extreme winter or summer conditions.

NOTE: A 5 minute delay may occur when the Fresh Air Cycle Setting is changed.

SOME GENERAL RULES, GUIDELINES, AND SUGGESTIONS

1. DO NOT install a fresh air intake duct/grille/register or hood, close to any type of exhaust system discharge, plumbing/sewer vent pipes, or furnace flue pipes! If it is unavoidable, make sure the fresh air intake is low to the ground or roof line, and the exhaust/vent discharge is at least four (4) feet higher than the intake. Check and Follow national and local mechanical codes and ordinances.
2. Use high quality intake or exhaust grilles & hoods with insect and rodent screens. Inspect and clean them periodically.
3. Installing a separate outside air filter will help prolong the life of your standard return air filter.
4. Use **hooded** intake and exhaust fittings to stop rain or snow from falling into your duct.
5. DO NOT install a return air damper or completely close off a return air damper, if your fresh air duct is under-sized, or completely closed off! **Example:** Return air main is 20"x25" and you install an 8" round fresh air duct & damper.....You will NOT install a return air damper.
6. In the above example, you really don't need an exhaust damper either. An 8" round duct will introduce approximately 210-275 cfm @ .08 - 0.1 friction factor. This additional air volume is enough to provide a slight positive pressure to the home or office. Better for the home to be slightly positive than negative. Insects have a harder time getting inside when the front or back door is opened.

Typical Gable & Roof-line

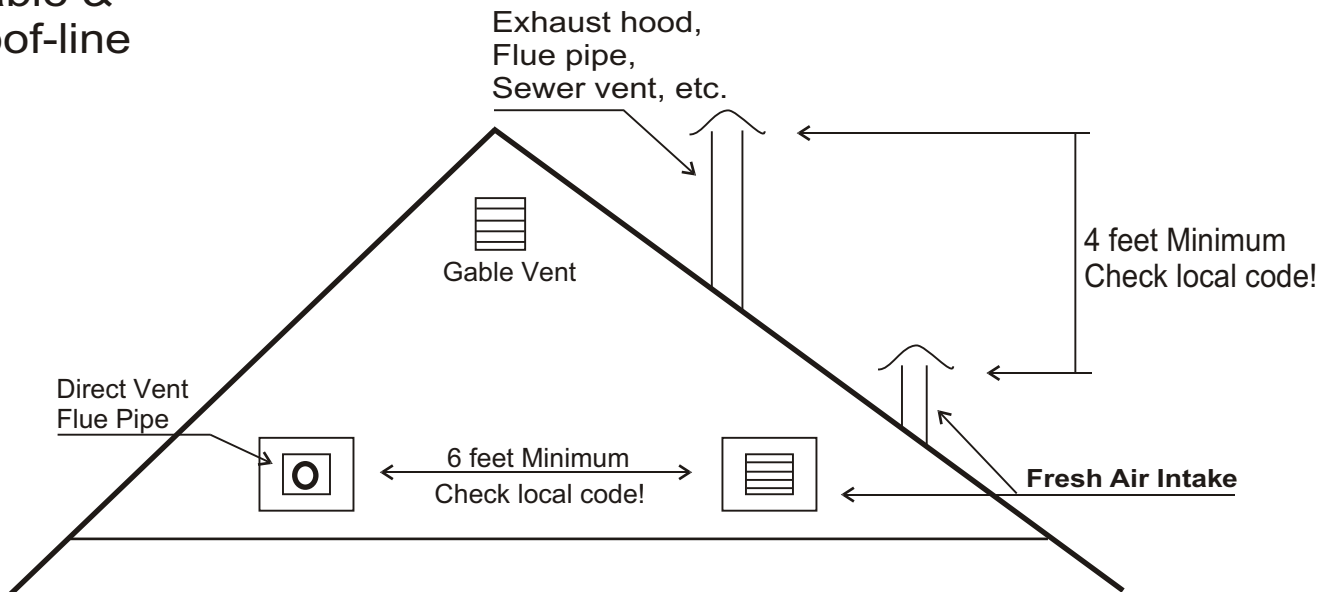

T R O U B L E S H O O T I N G

SYMPTOM

SOLUTIONS

LED'S are responding properly but HVAC system is malfunctioning.

Check HVAC system wiring for proper connections.
Check HVAC system wiring for shorts/miswiring.
Check HVAC System.
Refer to Technical Bulletin for correct setup/wiring.

LED's are not responding properly and HVAC system is malfunctioning.

Check HVAC system wiring for shorts/miswiring.
Check HVAC system wiring for proper connections.
Check HVAC thermostat for proper connections.
Refer to Technical Bulletin for correct setup/wiring.

LED's do not illuminate and HVAC system does not respond.

Check HVAC system supply voltage.
Check HVAC system 24vac transformer voltage/fuse/HKcircuit breaker.
Check HVAC system wiring for shorts/miswiring.
Refer to Technical Bulletin for correct setup/wiring.

LED's illuminate and HVAC system functions normally but dampers do not respond.

Check damper motor wiring for proper connections.
Check damper motor 24vac transformer voltage/fuse/HKcircuit breaker.
Check damper motor wiring for shorts/miswiring.
Refer to Technical Bulletin for correct setup/wiring.

REFER TO THE DAMPER MOTOR TROUBLESHOOTING SECTION ON PAGE 7.

CHECK YOUR WIRING

DETECTING 24vac SHORTS

SYMPTOMS

HVAC system not responding and HK2000 LED's are off.

If 24vac short has occurred, 24vac will be present at the *HK2000 System Input terminals R & C*; but 24vac will not be present at the Thermostat R&C terminals. *Caution: Circuit breaker will be hot!*

Dampers not responding and HK2000 LED's are on.

If 24vac short has occurred, 24vac will be present at the *HK2000 Damper Motor Input terminals RM & CM*; but will not be present at any Damper M1&M2 terminals. *Caution: Circuit breaker will be hot!*

ISOLATING 24vac SHORTS

SOLUTIONS: Remove 24vac power from HK2000 and allow circuit breaker(s) to cool!

F2 circuit breaker protects the HK2000 and reacts to a short in the thermostat field wiring.

Disconnect the wire from the *R terminal on the HK2000 thermostat terminal block* and restore power. If the short has gone away, check thermostat and wiring for shorts. Replace wires if necessary.

F1 circuit breaker protects the HK2000 and reacts to a short in a damper motor or the damper motor field wiring.

Disconnect all wires at all *damper terminal blocks (M1, M2, M4 & M6) one at a time, until the 24vac power restores to terminals M1 & M2*. Check the damper motors and wiring for shorts. Replace wires if necessary.

TECHNICAL SUPPORT

EWC Controls provides superior toll free Troubleshooting Support for the HK2000 when you are on the job site!
Call 1-800-446-3110 Monday - Friday 8am to 5pm EST
Otherwise call 1-732-446-3110 for information on the HK2000 and other ULTRA-ZONE products..

When calling for Technical Support, please have a multi-meter, pocket screwdriver, and wire cutter/stripper handy.

TESTING DAMPER MOTORS

RDN / SMDL / BMDL Dampers - Connect 24vac common to terminal 1 and 24vac hot to terminals 2 and 4. Damper should Open. Remove 24vac hot from terminal 4. Damper should Close.

BMD / SMD / ND / URD Dampers - Connect 24vac common to terminal 1 and 24vac hot to terminal 4. Damper should Open. Remove 24vac hot from terminal 4 and apply to terminal 6. Damper should Close.

SR / ESR Power Close / Spring Open Dampers - Connect 24vac common & hot to the two motor (M) terminals. Damper should Close. Remove 24 vac hot. Damper should Open.

SR / ESR Power Open / Spring Close Damper - Connect 24vac common & hot to the two motor (M) terminals. Damper should Open. Remove 24vac hot. Damper should Close.

TESTING THERMOSTATS

During a demand for heating, the thermostat should apply a 24vac hot signal to the W terminal.

During a demand for cooling, the thermostat should apply a 24vac hot signal to the Y and G terminals.

During a continuous fan demand, the thermostat should apply a 24vac hot signal to the G terminal.

Check to make sure that the thermostat Rc and Rh terminals are connected together, unless your application requires separation of these circuits.

NOTES:

Remember that the drawings included in this bulletin are general in nature. Your actual field wiring may vary.

Contact EWC Controls if you are unsure as to the proper wiring for your application.

DO NOT connect these control panels or damper motor actuators to voltages higher than 30vac. Doing so will void all warranties.

DO NOT install or place a Fresh air intake, close to or adjacent to ANY type of exhaust system discharge. Consult National & Local building mechanical codes and ordinances.

Page 12 has a 2 stage Heat/Cool diagram showing a *required* Field Lockout relay for the “Y2” circuit. The “W1” circuit travels straight thru the HK2000, so “W2” can also be wired straight across.

Model HK2000 **ULTRA-ZONE™** Fresh Air/Economizer Control Panel 2 STAGE COOL / 2 STAGE HEAT WIRING DIAGRAM

NOTE: This diagram reflects "Dry Bulb" Mode.
Diagram also applies to "Enthalpy" Mode.

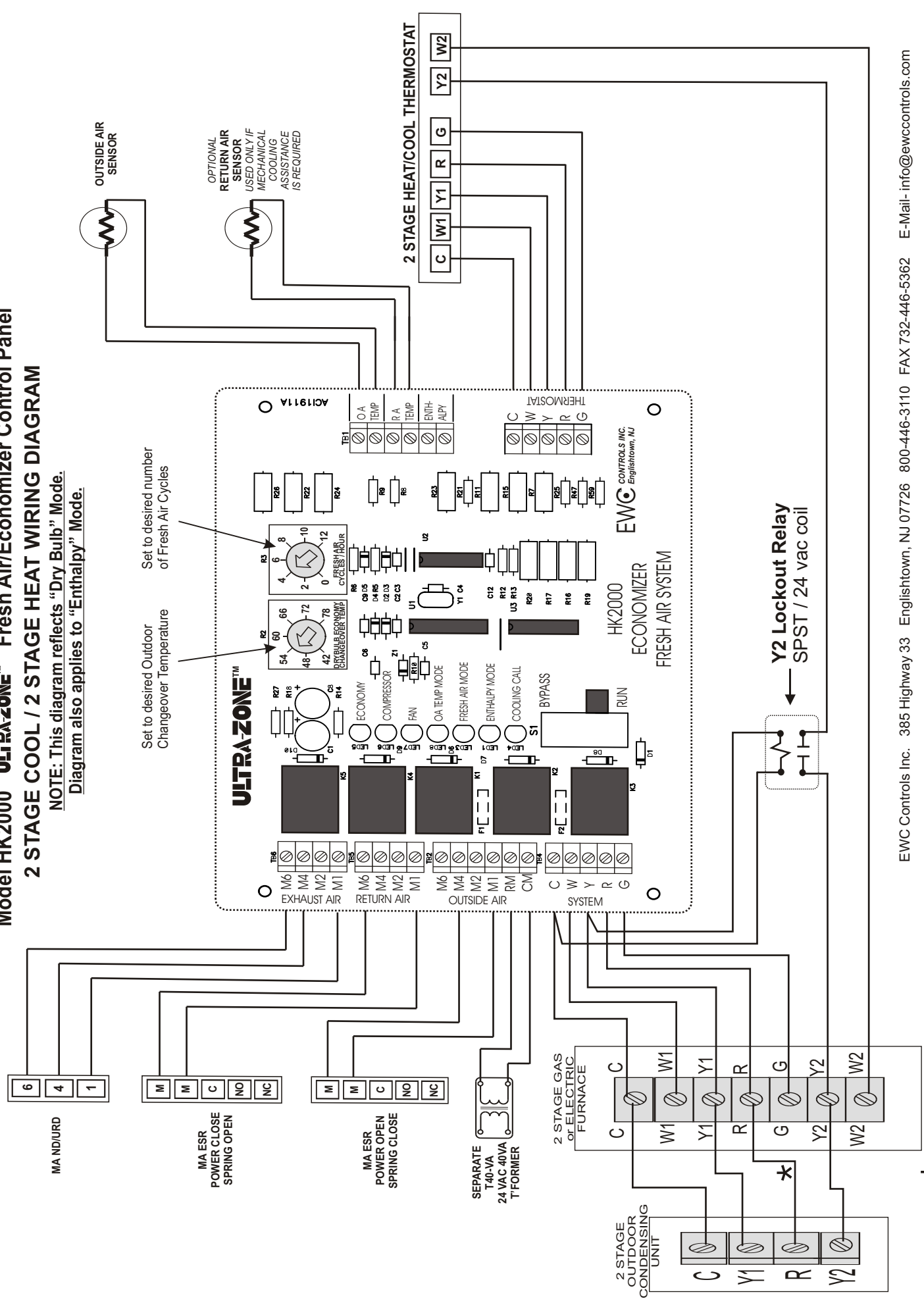

*** "R" connection to Outdoor Unit may not be required on your system!**